

Physics

Classes Nine-Ten



NATIONAL CURRICULUM AND TEXTBOOK BOARD, BANGLADESH



মুক্তিযুদ্ধের কয়েকজন শহিদ বুদ্ধিজীবী

১৯৭১ সালে বাংলাদেশের মুক্তিযুদ্ধের সময় জ্ঞানী-গুণী ও মুক্তবুদ্ধিসম্পন্ন মানুষ যারা পাকিস্তানি হানাদার বাহিনী ও তাদের এদেশীয় দোসর রাজাকার, আলবদর, আল শামস বাহিনী কর্তৃক পরিকল্পিতভাবে হত্যাযজ্ঞের শিকার হয়েছিলেন তাঁরাই শহিদ বুদ্ধিজীবী। শহিদ বুদ্ধিজীবীদের স্মৃতির উদ্দেশে বাংলাদেশে ১৪ই ডিসেম্বর শোকাবহ শহিদ বুদ্ধিজীবী দিবস পালিত হয়। বুদ্ধিজীবী হত্যা ছিল বাঙালিদের মেধাশূন্য করার জন্য পাকিস্তানি শাসকদের নীলনকশার বাস্তবায়ন। পাকিস্তানি শাসকগোষ্ঠীর নির্দেশনা ও মদদে একশ্রেণির ঘৃণ্য দালাল এই হত্যাযজ্ঞ সংঘটিত করে।

২০১০ সালে শেখ হাসিনা সরকারের আমলে গঠিত আন্তর্জাতিক অপরাধ ট্রাইব্যুনালে বুদ্ধিজীবী হত্যাকাণ্ডে জড়িত সাজাপ্রাপ্তদের অনেকের প্রাণদণ্ড ইতোমধ্যে কার্যকর হয়েছে। বাকিদের বিচার বাস্তবায়নের কাজ এগিয়ে চলছে। কালো পতাকা উত্তোলন, জাতীয় পতাকা অর্ধনমিতকরণ, মিরপুর শহিদ বুদ্ধিজীবী স্মৃতিসৌধে পুষ্পস্তবক অর্পণ, শহিদদের স্মরণে আলোচনা সভা, চিত্রাঙ্কন প্রতিযোগিতা, মিলাদ মাহফিলসহ নানা কর্মসূচির মধ্য দিয়ে বিন্দু শ্রদ্ধায় দিবসটি পালিত হয়।

**Prescribed by the National Curriculum and Textbook Board
as a textbook for classes nine-ten from the academic year 2013**

Physics

Classes Nine-Ten

**Reviewed and modified
for making the contents easy and accessible**

by

**Dr. Muhammed Zafar Iqbal
Dr. Mohammed Kaykobad**

Last edition written by

**Dr. Shahjahan Tapan
Dr. Rana Chowdhury
Dr. Ekram Ali Sheikh
Dr. Rama Bijoy Sarker**

Last edition editor

Dr. Ali Asgar

Last edition translated by

**Dr. Rama Bijoy Sarker
Sudeb Chandra Paul
Md. Khairul Alam**

Re-translated by

**Dr. Rama Bijoy Sarker
Sudeb Chandra Paul
Swapan Chandra Barman
Md. Akter Hossain**

National Curriculum and Textbook Board, Bangladesh

Published by
National Curriculum and Textbook Board
69-70, Motijheel commercial Area, Dhaka.

[All rights reserved by the Publisher]

First Publication : September, 2012
Revised Edition : November, 2017
Reprint : ,2022

Cover : Nasreen Sultana Mitu
Illustrations : Mehedi Haque, Nasreen Sultana Mitu
& Romel Barua
Photography : SUST SUPA & Collected
Overall Coordination : Mohammed Jaynal Abedin

Design

National Curriculum and Textbook Board, Bangladesh

For free distribution by the Government of the People's Republic of Bangladesh

Printed by :

Preface

The aim of secondary education is to make the learners fit for entry into higher education by flourishing their latent talents and prospects with a view to building the nation with the spirit of the Language Movement and the Liberation War. To make the learners skilled and competent citizens of the country based on the economic, social, cultural and environmental settings is also an important issue of secondary education.

The textbooks of secondary level have been written and compiled according to the revised curriculum 2012 in accordance with the aims and objectives of National Education Policy-2010. Contents and presentations of the textbooks have been selected according to the moral and humanistic values of Bengali tradition and culture and the spirit of Liberation War 1971 ensuring equal dignity for all irrespective of caste and creed of different religions and sex.

Honorable Prime Minister, Government of the People's Republic of Bangladesh, Sheikh Hasina expressed her firm determination to make the country free from illiteracy and instructed the concerned authority to give free textbooks to every student of the country. National Curriculum and Textbook Board started to distribute textbooks free of cost since 2010 according to her instruction. In its continuation, this textbook has been reviewed and updated with a view to create a developed and resourceful Bangladesh keeping vision 2041 ahead.

Physics is inextricably related to the development of technology from the very beginning of civilisation. Tools and techniques of physics are widely used in the field of engineering, astronomy, oceanography, biology, psychology etc. The study of physics is necessary for those who are interested in the above mention subjects. Four colour illustrations have been used to make content attractive and visible to the learners. So it is expected that learners will be inspired to study this subject for future.

Considering the challenges and commitments of 21st century and following the revised curriculum the textbook has been written. The textbook has been revised and re-edited by a prominent educationist to make it learner friendly in 2017.

I thank sincerely all who were involved in the process of revision, writing, editing, art and design of the textbook for their intellectual labour.

Professor Md. Farhadul Islam

Chairman

National Curriculum and Textbook Board, Bangladesh

CONTENTS

Chapter	Subject	Pages
One	Physical Quantities and Their Measurements	1–30
Two	Motion	31–60
Three	Force	61–96
Four	Work, Power and Energy	97–126
Five	State of Matter and Pressure	127–159
Six	Effect of Heat on Matter	160–186
Seven	Waves and Sound	187–210
Eight	Reflection of Light	211–241
Nine	Refraction of light	242–277
Ten	Static Electricity	278–306
Eleven	Current Electricity	307–337
Twelve	Magnetic Effects of Current	338–354
Thirteen	Modern Physics and Electronics	355–388
Fourteen	Physics to Save Life	389–408

Chapter One

Physical Quantities and Their Measurements



Figure: An Atomic clock made for measuring time very accurately

When you think about science, the image of different instruments, inventions, research laboratories etc. might appear in your mind. But the instrument, research or laboratory are not the subject matter of science; the actual subject matter of science is its scientific view . The greatest contribution of this civilization has come from science and that came from the scientific view of the human beings of the world. To explore the mysteries of science, sometimes they are explained with logic, sometimes examined in laboratories and some other times they are scrutinized intensively in nature. From the ancient time to modern era the scientists are relentlessly working to advance science. The gradual development of physics has been described in this chapter.

If we read the history of physics we will see that it is developed by the combined efforts of both theoretical and experimental scientists. In order to carry out research in the laboratory, we need to measure different quantities precisely. This chapter offers discussion of how the measuring units are developed, how one can measure and what type of instrument are used for measuring them.



By the end of this chapter we will be able to-

- explain the scope and gradual development of physics.
- describe the objectives of studying physics.
- explain the physical quantities [with units and magnitude] and the origin of physics.
- explain the necessity of measurement and units.
- explain the difference between fundamental and derived quantities.
- explain the international system of measuring units.
- calculate the dimensions of quantities.
- calculate the transformation of prefixes of multiple and sub-multiple units.
- express the concepts and theories of physics by using scientific terms, symbols and signs.
- measure physical quantities using different apparatuses.
- explain the techniques/methods of exactness and accuracy of measurement.
- determine the area and volume of uniform objects by using simple instruments.
- determine the length, mass, area and volume of uniform objects used in our daily lives.

1.1 Physics:

Physics is the most ancient branch of science. It is because scientists started studying and practising astronomy, the most important branch of physics, before other branches of science had flourished. Besides, being the oldest branch, physics can be said to be the most fundamental branch of science. Chemistry flourished on the basis of physics. Biology flourished on the basis of Chemistry, and again, many other subjects flourished on the basis of Biology.

Generally, we can say that the branch of science that tries to understand matter and energy and the interaction between them is called physics. You must have realized that here physics does not refer to only the visible things around us but also the things such as molecules-atoms, electrons, protons, neutrons, quarks or string etc. Again energy may encompass strong and weak nuclear energy apart from our known potential energy, kinetic energy, gravitational energy or electromagnetic energy.

1.2 Scope of physics

Since physics is the oldest and the most fundamental branch and other branches somehow flourished on the basis of physics, it is very natural that the scope of physics is very vast. Not only that, different technologies have flourished based on different laws of physics and we are using these in our daily lives (there are examples of some instruments used in medical science in the final chapter). At present the greatest contribution behind civilization is of electronics and physics has the greatest contribution to this technology also. Besides daily activities, from destruction of war to space exploration, the contribution of physics is present. Not only that, by the combination of other branches of science and physics, newer branches have developed, for example, astrophysics consists of astronomy and physics. In order to explain organic processes, biophysics has been built up by the combination of biology and physics, chemical physics was born by the combination of chemistry and physics. Use of physics in Geology has developed Geophysics. Medical physics has flourished using physics. Therefore the area of physics is very vast and deep as well.

For the advantage of teaching-learning we may divide physics into two principal parts. These are:

Classical Physics: This contains mechanics, sound, heat and thermodynamics, electricity and magnetism and optics.

Modern Physics: Modern Physics has been developed using Quantum Mechanics and Theory of Relativity. These are molecular and atomic physics, nuclear physics, solid state physics and particle physics.

We have mentioned earlier that many kinds of technologies have been developed in the world using physics or other branches of science. Using these technologies we have made our lives comfortable and meaningful. The invention of some dangerous technology has endangered not only our lives but also the existence of our earth. Sometimes unjustified and unnecessary technology has destroyed the resources of our earth along with creating pollution. So remember that technology is not always good, as there are good technologists in the world, also there are bad technologists. Using your conscience, you have to understand which technology is good or bad.

Physics was not built in a single day, it took hundreds of years to develop. The physicists tried to explain, with the help of laws, the mysterious world around them. Sometimes those laws were accepted, changed or rejected through experiments. Thus, we are able to explain microscopic particle of matter to shape of largest universe and we are learning continuously. Perhaps this learning is not complete still now- scientists are trying to make it complete, it will be possible to explain everything of apparently different subject with the help of a few laws one day.



Do Yourself

Technology may be good or bad but knowledge can never be bad. In the light of invention of physics give logical arguments in favour of this.



Group Work

Arrange a debate on good technology and bad technology that have been developed using the laws of physics.

1.3 Development of physics

Modern civilization is the contribution of science. This advancement of science has not been achieved in a day. The modern science reached its present state gradually following tireless labour of innumerable scientists and researchers. It has to be remembered that, in ancient time the exchange of information was not so easy, it was very difficult to convey the results of research to one another, books were written by hand form and the number of such books were very few. Courage was needed to express views against conventional faiths. There are examples of imprisonment or even scientists being burnt to death. But the search for knowledge was not stopped and by exploring the mysteries of nature, the scientists have given us this modern science as a gift.

We can describe the history of physics by dividing it into different stages.

1.3.1 Initial Stage (Greek, Indian subcontinent, China and the Contribution of Muslim Civilization)

What we understand by physics at present was introduced in the ancient times, by the combination of astronomy, optics, dynamics geometry, and an important branch of mathematics. The name of the Greek scientist Thales (624–586 BC) can be mentioned specially, because he was the first to deny explanations which were only based on religion, myth and extrasensory perception but without logic. Thales predicted about the solar eclipse and knew about the magnetic property of loadstone. Pythagoras (527 BC) was remarkable among the mathematicians and scientists of that time. He had fundamental works on vibrating wire along with geometry. Greek philosopher Democritus (460 BC) presented the idea first that matter has indivisible units, called atom (This name is used by modern physics). It was not acceptable to all since there was no chance to prove his idea by any scientific process. The theory that everything was made of soil, water, air and fire by the greatest philosopher and scientist of that time, Aristotle was much more acceptable. Aristarchus (310 BC) first gave the idea of sun centered solar

system. His follower Seleucus proved those ideas with arguments, although these arguments have been lost with time. Greek science and mathematics reached its peak at the time of Archimedes (287 BC), the greatest scientist of all times. The upward thrust of liquids is still included in the content of science. He assisted, during the war, by setting enemy ships on fire by converging the solar light using a spherical mirror. There was another scientist of Greek era named Eratosthenes (276 BC), determined the radius of the earth accurately at that time.



Figure 1.01: Archimedes and Al Khorgimi

After that, the development of science came to a stand-still for almost one thousand and five hundred years. Only the civilizations of the Indians, Muslims and Chinese kept practising the study of science following Greek convention. In the Indian subcontinent Aryabhata (476), Brahmagupta and Vaskar did a lot of valuable works on mathematics and astronomy. Zero was effectively used in the Indian subcontinent (Aryabhata). The name of Al Khorgimi (783 BC) has to be specially mentioned among the Muslim mathematicians and scientists. The present name algebra has come from the book *Al Zaber* written by him. Ibne Al Hayum (965 BC) is considered as the founder of optics. Al Masudi wrote an encyclopedia of thirty parts regarding the history of nature. Everyone knows the name of Omar Khayam as a poet. But he was a highly famous mathematician, astronomer and philosopher. Chinese mathematicians and scientists have done a lot of work in physics. Among them the name of Shen Kuor can be mentioned (1031), studied magnets and mentioned the technique of finding directions by using a compass during travel.

1.3.2 Rising Stage of Science

In the sixteenth and seventeenth century, a wonderful revolution started in the realm of physics. It was the era of European renaissance. In 1543 Copernicus gave the explanation of the solar centric solar system in a book. (the publisher of the book became afraid of the priest and wrote that it is not a real explanation, only a mathematical solution!) The theory was not made available to the people for a long time, Galileo (1564–1642) brought it to the fore front. He introduced the mathematical formulation. After that he introduced the scientific process to prove the law through experiments. Sometimes Galileo is called the father of modern science. He fell victim of the anger of the church as the founder of solar centric solar system. He had to pass his last days in captivity. In 1687 Newton published the three laws of mechanics and the law of gravitational force, which provided the foundation of force and dynamics. Besider optics and other works scientist Newton invented a new branch of mathematics called calculus along with Leibniz.



Figure 1.02: Copernicus , Galileo and Newton

Before the eighteenth century heat was considered a mass-less liquid. In 1768 Count Rumford showed that heat is a kind of energy and mechanical energy can be converted into heat energy. Lord Kelvin, in 1850, introduced two important laws of thermodynamics on the basis of the research work of many other scientists.

An extensive research started on electricity and magnets at that time. In 1778 Coulomb invented the law of force between charges. Many kinds of research were started after the invention of the electric battery by Volta in 1800. In 1820 Oersted showed that magnets can be made by the flow of electricity. In

1831 Faraday invented just the opposite process given by Oersted. They showed that electricity can be produced by varying the magnetic field. In 1864 Maxwell (Figure 1.03) expressed the varying electric and magnetic fields with a single law, the famous Maxwell equation. Here, he also showed that actually light is an electromagnetic wave. Electricity and magnets are not different. In fact they are the two forms of the same energy. This invention was well-timed because in 1801 Young proved the wave nature of light through experiments.

1.3.3. Introduction to Modern Physics

From the very beginning of 19th century scientists felt that many things could not be explained with the help of existing physics. Dalton introduced atomic theory in 1803, Thomson invented an electron within the atom, In 1911 Rutherford showed that at the center of the atom, there is the smallest nucleus and there are positive charges in it. But it was found that the revolving electron model around the nucleus could not be explained because, according to electromagnetic theory, an electron should radiate its energy and fall into the nucleus, but practically it never happens. In 1900 Max Plank invented the quantum theory and the explanation of the stability of an atom became possible. Professor Satyendranath Basu gave an appropriate mathematical explanation of the Quantum – theory of radiation. In recognition of his contributions to physics one kind of elementary particle was named the Boson. During the period of 1900-1930 many famous scientists together established the quantum theory.



Figure 1.03: Maxwell, Rutherford and Mari Curie

An imaginary medium called ether was considered as the carrier of the electromagnetic wave. In 1887 Michelson and Morley, while trying to prove the existence of ether, showed that actually there is no ether and the velocity of light is equal in both stationary and moving mediums. We get this explanation

from Einstein's theory of relativity in 1905. (Fig-1.04) The most wonderful equation $E = mc^2$ is derived from the theory of relativity in which it is shown that the mass of object can be converted into energy.

In 1931 Dirac hypothesised the existence of an anti particle by the combination of quantum theory and the theory of relativity and it was discovered the following year.

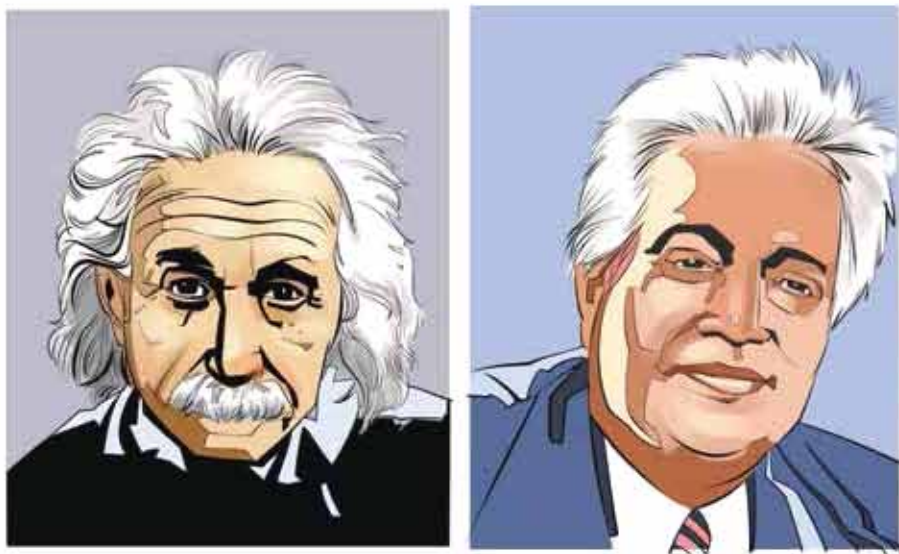

Figure 1.04: Albert Einstein and Satyendranath Basu

In 1895 Roentgen invented X-rays. In 1896 Becquerel showed that radioactive radiation is emitted from the centre of an atom. In 1899 Pierre Curie and Marie Curie (Fig:1.03) invented radium and the scientists understood that actually the atoms are not imperishable and on disintegrating, these atoms may emit radioactive radiation .

1.3.4 Contemporary Physics

Due to the invention of electronics and modern technology it is possible to make powerful particle accelerators. Accelerating the particle with high energy, new particles are being discovered. It is possible to arrange these particles systematically using the Theoretical Standard Model. It is possible to explain the structure of all the particles using a few elementary particles (and their antiparticles) though apparently we think there are an infinite numbers of new particles. It is not possible to explain the mass of the particles using the Standard Model, so to explain the mass, the existence of a new particle called the Higgs

Boson was proposed. The identification of the Higgs Boson particle in the laboratory in 2013 is treated as a great success of theoretical physics.

In 1924 Hubble showed that all galaxies of the universe are moving away from one another, which indicates that the universe is expanding slowly. This means that once upon a time the whole universe was concentrated at a point. Scientists showed that fourteen billion years ago through a massive explosion called the Big Bang the universe was created and it is continuing to expand. Very recently scientists showed that this expansion will never stop and every part of the universe will keep moving away from one another. Besides, the physicist have shown that they can explain only 4% of visible planets, stars, and galaxies of the universe, the concept of the mysterious dark matter and dark energy has to be accepted to explain the rest of the universe. The scientists are continuing their research in this field.

Semiconductors are created from the research of solid state physics resulting in present electronics which laid the foundation of modern civilization.

1.4 Objectives of Physics

Already you know that physics is that branch of science which explains the change of position of an object with time in the presence of energy and force. Like any other science the main objective of physics is to learn, the arena of knowing in physics is very large. The objectives of physics are to unfold the mysteries of both small atoms and the vast universe. For understanding easily we can divide the objectives of physics into three parts:

1.4.1 Unfold the Mystery of Nature

In ancient times in China, a piece of lodestone was seen to attract another by an invisible force. This special property of this special type of matter was called magnetism. Similarly in ancient Greece, when a substance called amber was rubbed with wool, they would attract each other with an invisible force. This special type of property is called electricity. Many research were conducted on it in the eighteenth century and the scientists discovered that, this is actually two different forms of the same force and this force is called an electromagnetic force. After the invention of radioactivity while explaining a special radiation called beta ray, a new type of force called weak nuclear force was discovered. Later, the physicists showed that electrometric force and weak nuclear force are the different forms of the same force. Their combination is called the electro

weak force. The physicists argue that two other forces in nature called gravitational force and nuclear force will be brought under the same law in the future.

Physics is unveiling the mystery of nature one after another. Similarly we can say that an object consists of molecules, later on we see that the molecules consist of atoms of elements. Despite the atoms being charge neutral, there is a positive charged nucleus at the center and surrounding it, electrons are revolving. Though an electron is an elementary particle, it is seen that the nucleus consists of protons and neutrons. It is seen that neutrons and protons also consist of elementary particles called quarks. At present the research topic is whether electrons and quarks are made of strings.

1.4.2 To Know the Laws of Nature

From time immemorial we know that if something is released from above, it falls downward and seeing this we can guess that the earth attracts everything towards its center. If physics stops after pronouncing only the existence of gravitation, this is not enough at all. The knowledge will not be appropriate until we precisely know the force by which an object of a definite mass attracts another object of another definite mass and how the force varies with the distance between them. Newton explained this law of nature properly with the help of the law of gravitation. The laws of nature can be used in many other places. So, the motion of a falling body is explained with the help of gravitation, similarly the rotation of the earth round the sun can also be explained. To know the laws of nature properly the scientists analysed them with argumentative discussions, while also conducting experiments in the laboratory. Behind the wonderful success of physics, both theoretical and experimental research have been conducted. The main objectives of physics is to find out the laws of nature by carrying out research in these two different fields.

1.4.3 Development of Technology Using the Laws of Nature

From the theory of relativity Einstein deduced the law $E = mc^2$ and showed that mass can be converted into energy. In 1938, by breaking a nucleus Otto Hann and Fritz Strassmann showed that the amount of mass reduced, is converted to energy.

Using this formula the nuclear bomb was made and dropped on Hiroshima and

Nagasaki in the Second World War and millions of people were killed within a second. Not only deadly weapons can be made but also it is possible to use for the good of mankind. Using this formula, nuclear power plants are made and also in Rooppur of our country a nuclear power plant is being made.

Solid state physics is a branch of physics where semiconductors are studied. Mixing some special elements with semiconductors, transistors are made. With the help of this technology great development of electronics has occurred and this has made a major contribution to the present civilization.

In this way we can show that physics has a small or large contribution in every field of technology. Contributions of physics only in medical science are discussed in the last chapter of this book.



Group Work

Prepare a poster on the development of physics.



Do Yourself

Consider a particular distance as a particular time on a straight line, put the important works that different scientists have done from the ancient period to the present time on the straight line and show that there is a dark period in the history of human civilization. Search out anyone reason, why there is a dark period?

1.5 Physical Quantities and Their Measurements

We all know that water becomes ice when it is cooled; it becomes vapor when it is heated. Peoples have been observing it from the very ancient times. This knowledge alone cannot be science completely, unless we can say at what condition and at what temperature water becomes ice after freezing or raising the temperature at what condition and at what temperature does it start to boil and becomes vapors. This means, in order to be science, everything has to be measured. The most important point of science is to be able to explain everything accurately after measuring them.

Table 1.01: Seven physical quantities in SI unit

Quantity	Unit	Symbol
Length	meter	m
Mass	kilogram	kg
Time	second	s
Electric current	ampere	A
Temperature	kelvin	K
Amount of substance	mole	mol
Luminous intensity	candela	cd

In this universe anything we can measure is called a quantity. In this physical world there are innumerable quantities which can be measured. For example, we can name, length, breadth, volume, weight, temperature, colour, rigidity, position, velocity, internal material, electrical conductivity, non-conductivity, elasticity, heat conductivity, non-conductivity, density, specific heat, pressure, melting point, etc, and we cannot finish this list. In brief, in the physical world the quantities are endless. You may think that to measure these infinite number of quantities, we have to prepare the definitions and units for these infinite number of quantities! Actually that is not true, you will be surprised hearing that (and definitely be happy) if we can fix seven units of seven quantities, we will be able to calculate everything using these seven units. These seven quantities are called fundamental quantities. When we express other quantity using these fundamental quantities that is called a derived quantity. The fundamental quantities are length, mass, time, electric current, temperature, amount of

substance and luminous intensity. These internationally recognized seven units of seven fundamental quantities are called SI units, (SI came from the France language term ‘System International d’Units) and these are shown in Table 1.01. Table 1.02 shows some very big to very small quantities of distance, mass and time.

Table 1.02: Very big to very small quantities of distance, mass and time

Distance	m	Mass	kg	Time	s
Nearest galaxy	6×10^{19}	Our galaxy	2×10^{41}	Big bang time	4×10^{17}
Nearest star	4×10^{16}	The Sun	2×10^{30}	Dinosaur vanished	2×10^{14}
Radius of solar system	6×10^{12}	The Earth	6×10^{24}	Birth of human	8×10^{12}
Radius of Earth	6×10^6	Ship	7×10^7	Single day	9×10^4
Height of Everest	9×10^3	Elephant	5×10^3	Human heart beat	1
Length of virus	1×10^{-8}	Man	6×10^1	Life time of muon	2×10^{-6}
Radius of hydrogen atom	5×10^{-11}	Dust	7×10^{-7}	Vibration of Green light	2×10^{-15}
Radius of proton	1×10^{-15}	Electron	9×10^{-31}	Vibration of 1 MeV gamma light	4×10^{-21}

1.5.1 Units of Measurement

Among these units second, meter and candela are defined before by some constants.

From May 2019 kilogram, kelvin, mole and ampere are also defined by some constant of Physics. Now it is possible to measure all units very accurately using these constant in any laboratory in the world.

Magnitude of fundamental constants those are essential to measure these seven units are specified forever. The magnitude of seven constants are shown in the **Table 1.03**

Constant	Magnitude
Velocity of light (c)	2,99,792,458 meter/second
Plank’s constant (h)	$6.62607015 \times 10^{-34}$ joule second
Charge of electron (e)	$1.602176634 \times 10^{-19}$ coulomb

Vibration of C_s^{133} ($\Delta\nu_{Cs}$)	9,192,631,770 hertz
Boltzmann constant (k_B)	1.380649×10^{-23} joule/kelvin
Avogadro constant (N_A)	$6.02214076 \times 10^{23}$ particles/mole
Luminous Intensity (K_{CD})	683 lumens/watt

New definition of these units:

Second (s): The time required to complete 9,192,631,770 vibrations by Cesium-133 (C_s^{133}) atom is called one second.

Meter (m): In vacuum the distance travelled by light in $1/299,792,458$ second called one meter.

Kilogram (kg): The mass which is obtained by dividing Plank's constant by $6.62607015 \times 10^{-34} \text{ m}^2/\text{s}$ is called one kilogram.

Ampere (A): Flow of $1/1.602176634 \times 10^{-19}$ numbers of charge equivalent to charge of electron in one second is called one ampere.

Mole (Mol): Amount of substance that contains $6.02214076 \times 10^{23}$ particles (Avogadro's number) is called one mole.

Kelvin (K): Amount of change of temperature with the change of 1.380649×10^{-23} joule heat is called one kelvin.

Candela (cd): One candela is defined as the amount of $1/683$ watt luminous intensity which is emitted by a source of light vibrating 540×10^{12} cycle per second into one Steradian solid angle.

You should have a practical idea about how much is meant by one meter, what amount of mass is one kilogram, what time is one second, how much hot is one kelvin temperature, what amount of electric current is one ampere, what is meant by one mole substance or what amount of light is one candela! Now let us try to give you that idea. Not only do you have to know it, but also you have to feel it. In general it can be

Table 1.04: New SI unit



said that:

- The distance from the feet to the stomach of a person of normal height is nearly one meter.
- The water contained in one liter bottle or the water kept in four glasses have a mass of nearly one kg.
- The time required to say three words '**one thousand one**' is approximately one second.
- If three mobile phones are charging at the same time, one ampere electric current is used. (a mobile is charged at nearly 5 V. So, current consumption will be 5 watt. If lights, fans, refrigerators of a residence run at 220 V and one ampere current is used, the power consumption will be 220 watt!)
- If we can feel the fever of anyone by hand, it can be said that his temperature has increased by one Kelvin.
- It is difficult to understand a mole, we can say a large spoon filled with water contains one mole of water molecules. In one cup water, there are ten moles.
- The light coming from a single candle can be said one candela.

You see that none of them are perfect measurements, but easy to realize. If you are habituated with this measurement, when in future you will calculate anything, then you will have a sense of proportion about it.

1.5.2 Prefix

To study science or physics we have to measure different things. Sometimes we need to measure the length of a galaxy (6×10^{24} m), or sometimes we have to measure the radius of the nucleus (1×10^{-15} m). To measure this huge difference in the distance it is not wise to use the same type of numbers. So internationally some SI prefixes have been made. Due to this multiplier we will be able to express a large or small number by a small prefix. These prefixes are shown in Table 1.05. In our daily life we always use these prefixes. To express distance we say 1 kilometer instead of 1000 meter. We say 1 megabyte instead of ten lac bytes to express the size of photographs of a camera.

Table 1.05: The multiples and sub-multiples used in the SI unit

deca	da	10^1	deci	d	10^{-1}
hecto	h	10^2	centi	c	10^{-2}
kilo	k	10^3	milli	m	10^{-3}
mega	M	10^6	micro	μ	10^{-6}
giga	G	10^9	nano	n	10^{-9}
tera	T	10^{12}	pico	p	10^{-12}
peta	P	10^{15}	femto	f	10^{-15}
exa	E	10^{18}	atto	a	10^{-18}

1.5.3 Dimension

We already know that though there is an infinite number of quantities around us, we can measure them with the help of seven units only. We have to know, in which units a quantity can be expressed. Often we also need to know how this quantity is formed with which fundamental quantities (length L , time T , mass M etc.). The power of different fundamental quantities in a quantity is called its dimension. For example, we will see next that force is the product of mass and acceleration. Again, acceleration is the rate of change of velocity with time. And velocity is the rate of change of position with time.

Therefore,

$$\text{dimensions of velocity: } \frac{\text{distance}}{\text{time}} = \frac{L}{T} = LT^{-1}$$

$$\text{dimensions of acceleration: } \frac{\text{distance}}{\text{time}^2} = \frac{L}{T^2} = LT^{-2}$$

In this book, when we will speak about a new quantity, we will try to mention the dimension of it at the same time. You will see that, this always will help you to understand the quantity, in a different way. To indicate the dimensions of a quantity in this book, it will be shown within third brackets. For example, force F is expressed as $[F] = MLT^{-2}$.

1.5.4 Scientific symbols and notations

The following methods are followed to write the symbol of units:

1. To express the value of a quantity, first we write a number, leave a space after it and then write the symbol of the unit. For example, 2.21 kg, $7.3 \times 10^2 \text{ m}^2$ or 22 K. The percentage (%) sign also follows the same rule. However no space is left after a number to write degrees ($^\circ$) minutes ($'$) and seconds ($''$).
2. Derived unit produced by multiplication is written using a space between two units, e.g. 2.35 N m
3. Derived unit produced by division is expressed as negative power or '/'. (e.g. ms^{-1} or m/s)
4. No punctuation mark or full stop is used with the symbols, as they are mathematical expressions but not the abbreviated form of anything.
5. The symbol of unit is written in straight font, for example, m for metre, s for second etc. But the symbol of quantities are written in italic or curved font, for example, *m* for mass, *v* for velocity etc.
6. The symbols of units are written in small letters, for example, cm, s, mol etc. But capital letters are used for those units which are taken from the name of scientists (N for Newton). If there are many letters in the unit then the first letter will be capital only (the unit from the name of Pascal is Pa).
7. The prefix (k, G, M) of unit will be attached with the unit (m, W, Hz) with no space. For example, km, GW, MHz.
8. Prefixes more than kilo (10^3) will be in capital letters (M, G, T).
9. The symbols of units will never be in plural form (e.g. not 25 kgs, always 25 kg).
10. We have to try to write any number or compound unit in a single line. A line break can be given between a number and a unit if it is really necessary.

1.6 Measuring Instruments

Once it was very difficult to measure different quantities of physics accurately. The job has become much easier due to electronics based instruments. For the physics that we will try to learn in this book, knowing how to measure distance, mass, time, temperature, electric current and voltage will be enough. Let us discuss what type of instruments we will use to measure these:

1.6.1 Scale

A Meter scale is used to measure small lengths and definitely you may have seen it. Since this is 100 cm or 1 m long, it is called a meter scale. Since in many places inch-foot is familiar still now (USA is an example!), inch is marked very often on the other side of a meter scale. One inch equals 2.54 cm.

We can measure up to the smallest division on a scale. A meter scale is generally divided up to millimeter, so using a meter scale we can measure the length of anything up to millimeter. Therefore, if we say the length of anything is 0.364 m, this means the length of this is 36 centimeter and 4 millimeter. Using a meter scale it is not possible to measure lengths smaller than this - that is, generally we can never say the length of a body is 0.3643 m. But from time to time, for microscopic purposes we have to measure the smallest length of objects of this type, which can be performed by using an interesting scale called vernier scale.

Vernier scale

Let us consider that the length of an object comes in between 4 and 5 millimeter marking i.e. the length of the object is greater than 4 mm and less than 5 mm. We can use the vernier scale to find how much fraction is greater than 4 mm. This scale is attached to the main scale and can be moved forward and backward (Figure 1.05). In the example shown in the figure the length of 9 mm of main scale is divided into 10 divisions on the vernier scale. Therefore every division of the vernier scale equals $\frac{9}{10}$ mm, i.e. less than a millimeter by $\frac{1}{10}$ millimeter. If the initial mark of the vernier scale coincides with any mark of the millimeter scale, then the next mark of the vernier scale will keep a separation of $\frac{1}{10}$ mm from the actual millimeter mark, and the next will keep a separation of $\frac{2}{10}$ mm, third one will keep a separation of $\frac{3}{10}$ mm and so on.

Therefore no mark of the vernier scale will coincide with the millimeter mark of the main scale, finally the 10th mark will coincide again with the ninth millimeter mark of the main scale.

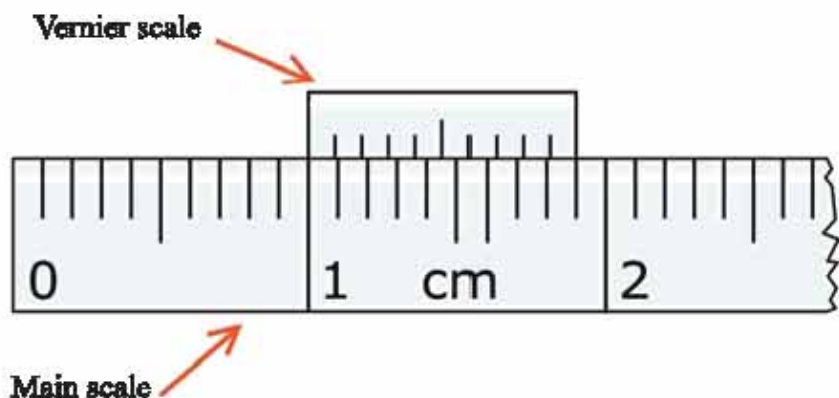

Figure 1.05: Main scale and movable vernier scale

If we keep the vernier scale in such a way that it does not start from a millimeter mark rather it starts with a slight (e.g. $\frac{3}{10}$ mm) displacement (Figure 1.06) then the number of $\frac{1}{10}$ mm displacements by which it has moved will be the mark of the vernier scale coinciding with the millimeter mark of the main scale! Therefore, it is very easy to measure a length using a vernier scale. First of all, we have to know the difference between one division of vernier scale and one division of the main scale- this is called the vernier constant-- in brief VC. This can be calculated if we divide the length of the smallest division (1 mm) of the main scale by the total number of divisions of the vernier scale (in the figure 1.05 and 1.06 it is 10). In our example, the value of this :

$$VC = \frac{1 \text{ mm}}{10} = 0.1 \text{ mm} = 0.0001 \text{ m}$$

To measure a length, we have to look at the vernier scale after measuring up to the last millimeter mark. The mark of the vernier scale that coincides exactly with any millimeter mark of the main scale is then found, and then that number is multiplied by the vernier constant. We will get the actual length by adding this amount with the length measured by the main scale. According to our procedure the length shown on the last scale of Figure 1.06 is 1.03 cm or 0.013 m.

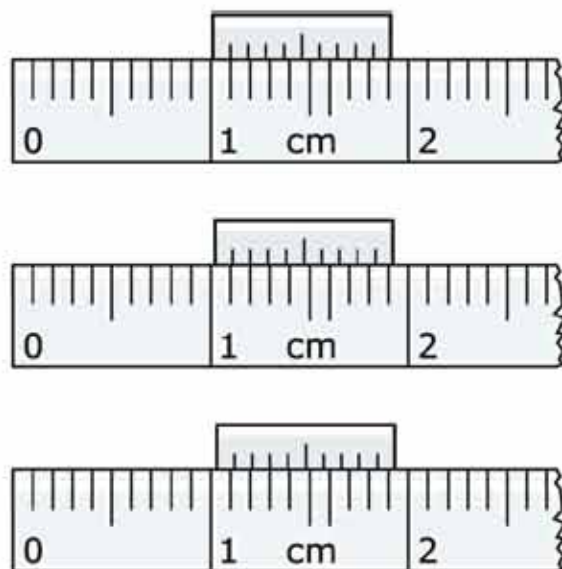

Figure 1.06: Vernier scale displaced by one, two and three divisions

Instead of the vernier scale we can use a special type of scale called a screw gauge to measure lengths. In a screw gauge when the screw (Figure 1.07) rotates, the scale moves forwards or backwards, the threads of the screw are kept very fine. After a complete rotation of the screw, the screw with the attached scale may advanced by 1 mm. This displacement of the screw is called the pitch of the screw. The circular part of the instrument, by the rotation of which the screw moves forwards or backwards is divided into 100 equal parts. For the rotation of only one division of the circular scale, the screw advances by $\frac{1}{100}$ of the pitch.

Therefore, with this scale up to $\frac{1}{100}$ mm = 0.01 mm of length measurement is possible. This is called the least count of the screw gauge.



Figure 1.07: A slide calipers with vernier scale and a screw gauge

Now-a-days instead of the vernier scale, attached dials or digital slide calipers are available by which lengths can be measured accurately.

1.6.2 Balance

Mass cannot be measured directly, so mass is generally determined by measuring the weight. When we say the weight of an object is 1 gm or 1 kg, then actually we mean that the mass of the object is 1 gm or 1 kg. In earlier times to measure the mass of an object, a balance was used, there the mass of the object was compared with the definite mass of a known weight. Now-a-days the use of electronic balance (figure 1.08) has increased a lot. If we keep the body on the balance then the sensors of the balance can determine the weight very precisely.



Figure 1.08: Digital weigh machine



Figure 1.09: Stop watch

1.6.3 Stop Watch

Stop watches are used to measure time interval (figure 1.09). Once accurate stop watches were very precious things. Now-a-days very accurate stop watches are available in the mobile phone at low prices due to the advancement of electronics. In a stop watch, time measurement is started at any instant of time, and by stopping the measurement of time after a definite interval, the elapsed time can be determined. An interesting matter is that the stop watch can

measure the time very accurately, but we can never start or stop it with our hands with the same accuracy.



Do Yourself

There is less probability for all of you to possess slide calipers but if you want, you can make a slide calipers to carry on your work. Make a photocopy of figure 1.10. Cut the part of the main scale and the vernier scale and then put it together after folding as shown in the figure following the steps (1, 2, 3, accordingly). Now you can measure any length accurately. The slide calipers is also graduated in inch. So to get the length in centimeter we need to multiply it with 2.54.

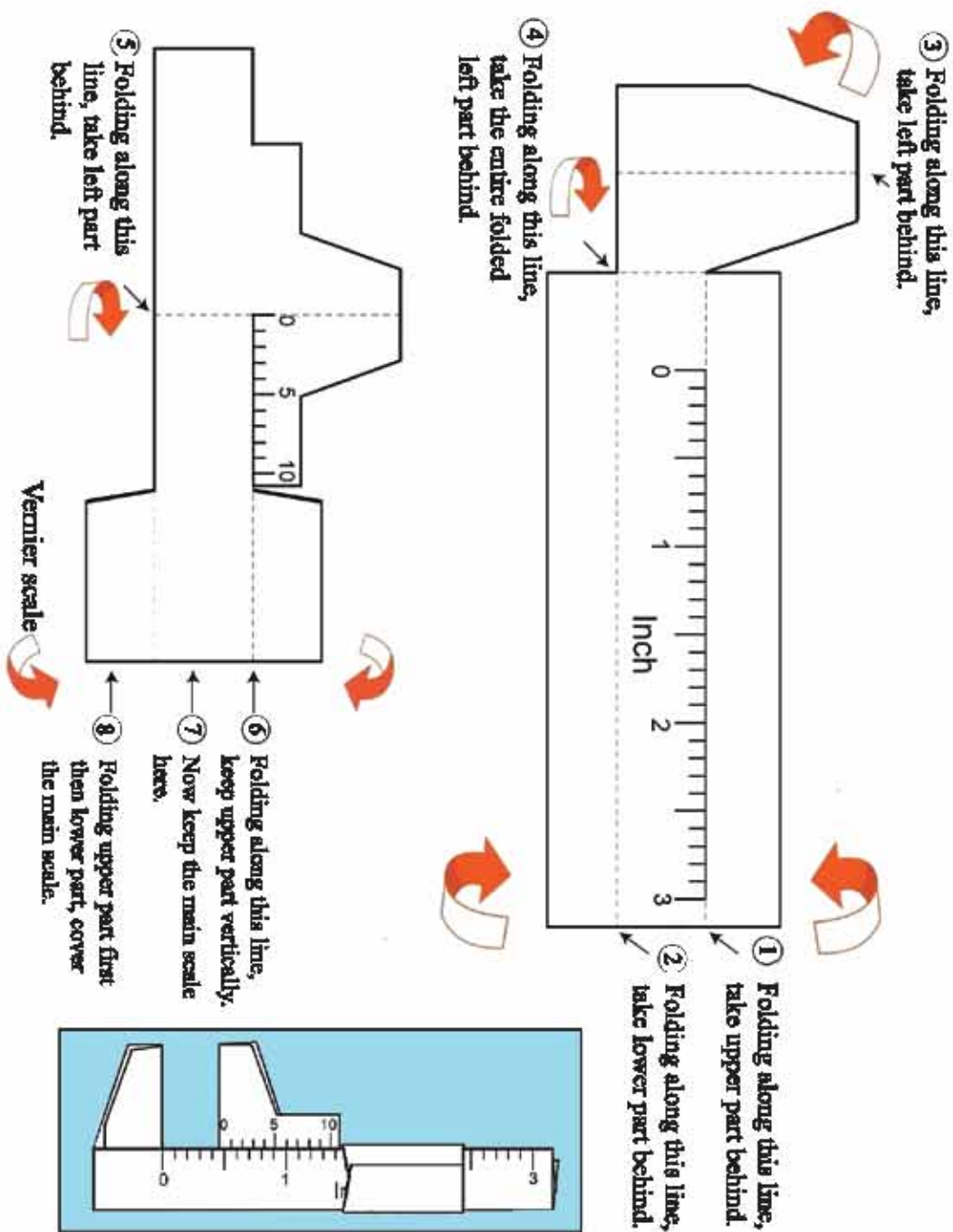

Figure 1.10 : Making slide calipers with paper



Investigation 1.01

Objective: To find out the volume of a match box or any other object by measuring its length, breadth and height using a slide calipers. If you have no slide calipers with you, you can make a slide calipers as shown in figure 1.10.

1. To measure the length of an object by slide calipers we need to place it between the jaws of the slide calipers. The jaws need to touch the object from both the sides.
2. Now observe carefully the mark of the main scale that the zero marking of vernier scale has just crossed. Mark of the main scale that the. That will be the main scale reading M . Notice that, the mark which is very close to the main scale, is not the reading of main scale, the mark that has just crossed the main scale fully is the main scale reading.

3. At this position find out which mark of the vernier scale coincides with any mark of the main scale, this is the vernier coincidence.

Measure the length of the object several times and put it in the table.

In the same way measure the breadth and height of the object.

Observation:

Determination of vernier constant:

Value of one smallest division of main scale, $S = \dots\dots\dots$

Total number of divisions of vernier scale, $n = \dots\dots\dots$

Vernier constant, $VC = s/n = \dots\dots\dots$

Table 1.06: Table of finding length, breadth and height of a rectangular object:

Object's	No. of observations	Main scale reading M	Vernier coincidence V	Vernier constant VC	Reading = $M + V \times VC$	Average reading
Length L						
Width W						
Height H						

1.7 Error and Accuracy

Error is a negative word and if the word "error in measurement" used, we think that the person who is doing the measurement is not performing his duties properly and an error has occurred! But this is not the case. Sometimes error may occur due to the person who is doing the measurement for his negligence, but we have to know that the instrument with which we measure is not error free. Therefore, there is a limit of how much accurately we can measure, i.e. it is very natural to have errors in measurement. But there is a need to measure to what extent a measurement is accurate. The reliability of a result will be increased if we can inform how accurate the result is when we publish the result of an experiment. You can report the measurement of the accuracy of your experiment if you know some conventional rules for finding the accuracy of an experiment.

Suppose, you are measuring the length of an object by a scale. How accurately you will measure the length of the object depends on how finely your scale is graduated. If the scale is graduated in 1 cm intervals then you will express your result for length in some definite number of cm. But the real length of the object is not exactly equal to this mentioned number of cm but perhaps very close to it, so there is a possibility of uncertainty in your measured length. That is why, we add that amount of uncertainty with the measured result. Therefore, if we see the length is close to 4 cm, we will say the length of the object is:

$$4.0 \pm 0.5 \text{ cm}$$

Therefore the length of the object may have any value within 3.5 cm to 4.5 cm.



Example

Question: What is the length of the object shown in Figure 1.11?

Answer: The length of the object is 7 ± 0.5 mm. That is, the length of the object will be of any value from 6.5 mm to 7.5 mm.

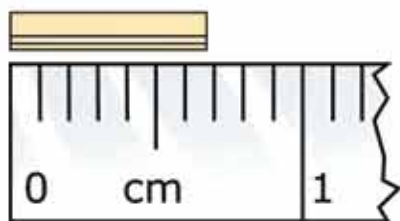

Figure 1.11 : The length of the object beside the scale is nearly 7 mm

Now we can discuss how accuracy can be measured. The measurement of accuracy is the absolute error. Observing the name we understand that this is the difference of the measured value with respect to the actual value. You can definitely understand that when we measure anything we don't know the actual value. So, instead of absolute error we use the most probable error. Therefore in our previous example the absolute error is

$$|\pm 0.5 \text{ mm}| = 0.5 \text{ mm}$$

We can consider the relative error after the absolute error. Let us consider that an error of 0.5 mm has occurred while measuring length. If the length of the object is 1 mm then this error is very serious, but if the length is 1 m then the measurement is accurate enough. The concept of relative error has been introduced to give a better understanding.

Therefore,

$$\text{Relative error} = \frac{\text{Absolute error}}{\text{Measured value}}$$

So in our previous example:

$$\text{Relative error: } 0.5 \text{ mm} / 7 \text{ mm} = 0.071$$

$$\text{In percentage this is: } 0.071 \times 100 = 7.1 \%$$

Question: Suppose you have got 10 cm by measuring the length of a square shaped book. Suppose the relative error in the measurement is 10%. What is the relative error in its area?

Answer:

$$\text{Measured area of the object} = 10 \text{ cm} \times 10 \text{ cm} = 100 \text{ cm}^2$$

Since the relative error of the object is 10%, hence if its length is measured, the minimum length will be 9 cm and maximum length will be 11 cm.

$$\therefore \text{The minimum area} = 9 \text{ cm} \times 9 \text{ cm} = 81 \text{ cm}^2$$

$$\text{and the maximum area} = 11 \text{ cm} \times 11 \text{ cm} = 121 \text{ cm}^2$$

Therefore the absolute error:

$$|100 \text{ cm}^2 - 81 \text{ cm}^2| = 19 \text{ cm}^2$$

$$\text{or, } |121 \text{ cm}^2 - 100 \text{ cm}^2| = 21 \text{ cm}^2$$

Since the values are not equal, we consider the larger one i.e. the absolute error is 21 cm^2

Therefore, the relative error = $21 \text{ cm}^2 / 100 \text{ cm}^2 = 0.21$

In percentage, $0.21 \times 100 = 21\%$

If the error in the measurement of the length is 10%, then in the case of area it will be approximately double. Similarly you can show that in the case of volume measurements the error will be three times!

Question: You have measured a box by a ruler which is graduated only in cm. You have got the length, breadth and height of the box as 10 cm, 5 cm and 4 cm respectively. What is the percentage of error in your measurements?

Answer: Since your ruler is graduated only in cm, so your error is $\pm 0.5 \text{ cm}$. Therefore the error in your measurements:

Length: $10 \pm 0.5 \text{ cm}$

Breadth: $5 \pm 0.5 \text{ cm}$

Height: $4 \pm 0.5 \text{ cm}$

Your measured volume: $10 \text{ cm} \times 5 \text{ cm} \times 4 \text{ cm} = 200 \text{ cm}^3$

Probable smallest volume:

$$(10 - 0.5) \text{ cm} \times (5 - 0.5) \text{ cm} \times (4 - 0.5) \text{ cm} = 149.625 \text{ cm}^3$$

Probable largest volume:

$$(10 + 0.5) \text{ cm} \times (5 + 0.5) \text{ cm} \times (4 + 0.5) \text{ cm} = 259.875 \text{ cm}^3$$

Therefore the volume,

$$149.625 \text{ cm}^3 < V < 259.875 \text{ cm}^3$$

Absolute error:

From 149.625 cm^3 to 200 cm^3 is $200 \text{ cm}^3 - 149.625 \text{ cm}^3 = 50.375 \text{ cm}^3$

From 200 cm^3 to 259.875 cm^3 is $259.875 \text{ cm}^3 - 200 \text{ cm}^3 = 59.875 \text{ cm}^3$

Considering the largest value we have the absolute error 59.875 cm^3

Relative error: $59.875 \text{ cm}^3 / 200 \text{ cm}^3 \times 100 = 29.9375\% \cong 30\%$

? Exercise



General questions

- Write a report on why we may study physics.
- Wonderful advancement took place in the twentieth century-support the statement with examples.
- What do you mean by a quantity?
 - Write down the difference between fundamental and derived quantities.
- In SI unit which quantities are considered as fundamental quantities?
 - Write down the names of the units of these quantities.
- What do you mean by dimension?
- Arguments, experimentation and observation- among these three methods which one would you prefer as the most important for science research.
- Among the seven SI units, one is little bit different from the others. Can you say which one and why?
- If you and everything around you suddenly becomes half in size, will you be able to understand the changes?
- Will you be able to measure the radius of the earth?



Mathematical questions

- Express the numbers given below using the prefixes in Table 1.05
(a) 10^{12} Flops (b) 10^9 bytes (c) 10^{-3} gm (d) 10^{-18} m
- In one year how many seconds are there? (for fun express in terms of π)
- How many meters are there in a light year?
- When measuring the length of a bar with a vernier scale, it looks as in figure 1.12. What is the length of the bar?

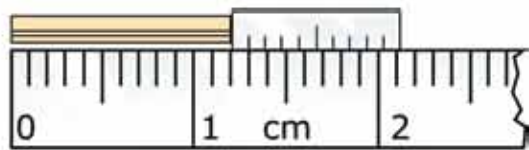

Figure 1.12: Reading of a vernier scale

- The dimension of energy is ML^2T^{-2} , in SI units what is its unit?



Multiple choice questions

Put tick (✓) mark on the correct answer

1. Who has given the quantum theory at first?

- a) Planck b) Einstein
c) Rutherford d) Heisenberg

2. The name 'boson' came from?

- a) Jagadish Chandra Basu
b) Subhash Chandra Basu
c) Satyendranath Basu
d) Sharat Chandra Basu

3. Which of below is not a fundamental quantity ?

- a) Mass b) Heat
c) Electric current d) Quantity of substance

4. When a rod is placed between the jaws of a slide calipers, the main scale reading is found to be 4 cm, the vernier super-imposition is 7 and if the vernier constant is 0.1 mm, what is the length of the rod?

- a) 4.07 cm b) 4.7cm
c) 4.07 mm d) 4.7 mm

From the figure below answer questions 5 and 6.

5. What is the volume of figure (b)

- a) $\frac{1}{2} \pi r^3$ b) $\frac{4}{3} \pi r^3$
c) $\frac{3}{4} \pi r^3$ d) πr^3

6. The ratio of the volume of figure (a) and figure (b):

- a) 1: 0.673 b) 1: 0.0673 s
c) 1: 0.763 d) 1: 0.637

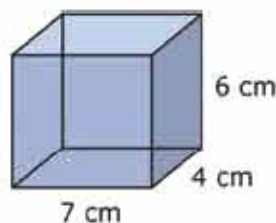

(a)

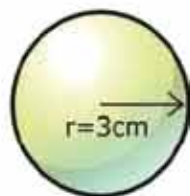

(b)

Figure 1.13: A block and a cylinder



Creative questions

1. Rashed, with his newly purchased scale, measured the length of his pencil and the length came to 11.73 cm. His friend Sujon said that this measurement may not be correct. Rashed said that he obtained the same result measuring by the scale several times. When they went to the teacher, he instructed them to use a vernier scale of constant 0.005 cm. Rashed measured the correct length by the vernier scale.

- What is the vernier constant ?
- Why are units required to express the amount of a quantity?
- Find how many divisions of vernier scale is equal to what number of divisions of main scale.
- The first measurement of length measured by Rashed was irrelevant to accurate measurement, explain with logic.

2. Mr Rashid, a science teacher, has given a ruler and a box to the students in his physics class and told them to determine the volume of the box. The students observed that the ruler could be used to measure upto cm only. They determined the length, breadth, and height of the box as 20 cm, 15 cm and 10 cm respectively.

- What is its dimension?
- Why weight and mass are not the same type of quantity?
- Determine the percentage of relative error in the measurement of volume of the box?
- This ruler is appropriate for measuring the area of the book but not suitable for measuring the area of the house- analyze the statement.

Chapter Two

Motion



There are many kinds of motions around us. When a person rides a cycle, it's a kind of motion. When a car moves, that is another kind of motion. When a plane flies, it is also a motion. When the earth revolves round the sun, it is also a motion. When a hanging bulb oscillates, it is a kind of motion. When a bullet ejects from a rifle, it's a motion also. Apparently it seems that all these several types of motions are of different types. But you will be surprised and happy to know that all these motions can be explained by a few number of quantities. In this chapter those quantities, their units, dimensions and the relationship among them will be discussed.



By the end of this chapter we will be able to-

- explain rest and motion.
- find out the differences among the different types of motion.
- explain scalar and vector quantities.
- analyse the relations among the quantities regarding motion.
- explain the motion of freely falling bodies.
- analyse the relations among the quantities regarding motion with the help of graphs.
- realize the effects of motion in our lives.

2.1 Rest and Motion

We don't have any problems in understanding which object is at rest or in motion around us. We observe by our eyes in such a way that when anything moves slightly, we can recognize it very quickly. So, we can realize easily what the terms rest and motion mean. But in physics, it is not sufficient only to realize these terms rather they have to be well defined. To define them, we can say briefly, when an object does not change its position with respect to time, then it is at rest. And when an object changes its position with time, then it is in motion.

Now we need to explain the term 'position' properly. In our daily conversation we use the word 'position' in different ways, but in physics the word 'position' has a definite meaning. If you are asked, what is the position of your school and if your answer is 'Jhiltuli', your answer is correct but the position of your school remains unknown. If you reply, your school is 1 kilometer from the gate of your residence; the position of your school is still unknown. Though the position of the gate of your residence is known to us, yet we cannot tell exactly in which direction the school is situated at a distance of 1 kilometer from the gate. But if you say the school is situated 1 kilometer east from the gate of your residence, only then we will know the exact position of your school. That is to know the position of the school; we have to know both the distance and the direction definitely. Not only this, this distance and direction has to be specified from the position of a reference point. In the case of your school the gate of your residence was the reference point or origin. Instead of your residence gate, the reference point might be a bus stop or a shopping mall. Then definitely both the position and the direction would have different values; but we can specify certainly the position with respect to the new reference point. That is, to specify the position of any object, it has to be mentioned with respect to a reference point. This reference point is not an absolute one; we can conveniently choose any point as reference point or origin.

Now the question is, to specify the position of an object, is it necessary for the reference point or origin to be a static point? Let us think; in front of you a person is sitting still on a chair. If we consider the chair as the reference point or origin, we can firmly say, the position of your friend is not changing.

But if it happens that actually you are sitting in a moving train, what will it then be?

A man outside of the train standing on the station will say, you and your friend are both in motion, nobody is at rest. Then whose statement is true? Your statement or of the man standing in the station? In fact, both are correct! The reason is- if the reference point or the origin moves at a uniform velocity, then we cannot tell firmly whether the reference point is moving at a uniform velocity or actually it is at rest and all other things are moving at uniform velocity in the opposite direction. Therefore, we can say, if an object changes its position with respect to an origin, then the object is in motion with respect to that origin. It is not our headache whether the origin is at rest or moving at uniform velocity. This is not important since every motion is relative.

Not only this, if we want to search out an absolute rest reference point, we will be in trouble. If we consider anything on the surface of the earth as origin, one can object, as earth is not stationary rather it is rotating about its own axis, so everything on its surface is also rotating. Alternatively we can say, the center of the earth is the origin. Then someone else can come up with the objection that the centre of the earth is not stationary, it revolves round the sun. Then we can say more intelligently, the centre of the sun must be the origin! Then another person can confidently say that the sun is also not stationary it is also revolving around the centre of our galaxy. Surely you are feeling that no one can dare to say, the centre of our galaxy is the origin! Who can say that the galaxy and the universe are stationary? Not only this, if the centre of the galaxy is considered as the origin to describe any position on the surface, do you realize the extent of complexities that may arise?

In fact, we don't need such type of complexities; for our purpose, we can consider any point as the origin, which seems stationary to us. In this case we have to mention all the measurements are done with respect to this origin. In this way scientists have done all the measurements starting from the nucleus of an atom to the satellites launched in space, with no problems what so ever!

2.2 Different Types of Motion

We see various types of motions around us, vibrations, rotations and separations – all these are the examples of different kinds of motions. Probable motions are unlimited, but if we wish, we can talk about some important types of motion separately.

Linear motion

It is an example of the easiest type of motion. If anything moves along a straight line then its motion is called linear motion. If an object is pushed off on a

plane surface then it moves along a straight line. If a ball is allowed to fall from a height, it will fall straight downwards, so it is also a linear motion.

Circular Motion

When a body rotates about a particular point or a line, keeping the distance of the particles of the body unchanged, it is called circular motion. Though the motion of electric fans, the hands of clocks etc. are examples of circular motion, a wonderful example of circular motion is the moon in the sky. The moon is not tied by to the earth although it is revolving around the earth, neither is it falling on to the earth's surface.

Translational motion

If an object moves in such a way that all the particles of the object travel the same distance, at the same time, in the same direction then its motion is called translational motion. Sometimes we see many examples of this type in our surroundings. When something moves in a straight path then its example is very common. If we do not consider the circular motion of the wheel of a car then straight advancement of the car is an example of translational motion. At this time every point of the car will travel the same distance, in equal time, in the same direction.



Figure 2.01: Example of translational motion

There is no obligation that the translational motion will be straight. But the example of translational motion is not easily available in the case of a curved path. Figure 2.01 shows how a plane has to move for every point of the plane travelling equal distances in the same direction. The figure also shows why the example of translational motion on a curved path is so rare.

Periodic Motion

If the motion of a moving object passes repeatedly through a definite point in the same direction in the same manner in a definite interval of time, then this motion

is called a periodic motion. The vibrational motion of our heart is periodic, since it vibrates in the same direction in the same manner after a definite interval of time. The periodic motion may be circular (motion of the blades of a fan), hyperbolic (orbit of Haley's Comet around the sun) or linear (oscillatory motion of an object hanging from a spring). Circular motion is a special type of periodic motion.



Figure 2.02 : Example of simple harmonic motion

Simple Harmonic Motion

Simple harmonic motion is a special type of periodic motion. In case of oscillatory motion the object oscillates on both sides of a definite point. Starting from its complete rest position, the object starts moving slowly. When the object comes to the centre, it has the maximum velocity, then its velocity starts to decrease until it comes to rest. Then it changes its path of motion and moves in the opposite direction. In the opposite direction when maximum velocity is attained, then its velocity decreases again. It stops its motion completely, and starts to repeat its motion slowly again in the previous direction. It continues its motion in this fashion.

There are so many examples of oscillatory motion around us. The motion of an object hanging from a spring is an example of oscillatory motion. The oscillatory baby on a swing (Figure 2.02) or the pendulum of a clock are the examples of oscillatory motion. When we speak, the air molecules carry the sound forward by this type of motion.

So far we have discussed some special types of motion but the causes of these motions have not been mentioned anywhere. The major success of physics is that not only can it find the causes of the different types of motion of objects but it can also explain the motion very clearly.

Can you guess the cause of the motion?

2.3 Scalar and Vector quantities

In the world we know anything that can be measured is called a quantity. Joy and sorrow are not quantities but temperature is a quantity. Because joy and sorrow cannot be assigned a value by measuring them but temperature can be given a value by measurement. The temperature of your body is 37°C or 98.4°F . To express temperature a single number is sufficient, but there are many quantities which cannot be expressed by a single number completely; with its magnitude its direction has to be mentioned or more than one magnitude has to be mentioned so that they altogether can express definitely the magnitude and direction of the quantity. Position is a quantity of this type; to express this only the distance is not sufficient; its direction has to be mentioned too. The quantity which can be expressed only by a single number is called a scalar quantity, on the other hand the quantities for which direction has to be mentioned in addition to its magnitude are called vector quantities.

Besides temperature examples of scalar are time, length and mass. Because they can be expressed by a single number only. Besides position you will find the other examples of vectors are velocity and force. You will be introduced with velocity and force in the next chapter. Because to express these quantities, direction is to be mentioned along with its magnitude.

To differentiate vector quantities from scalar quantities they are written in bold font (e.g. \mathbf{x} , \mathbf{y} or \mathbf{A} , \mathbf{B}). In books or in computer printing it is easy to write anything in bold form. But when anyone writes on a paper then to express anything as vector, a small arrow is used over it (\vec{x} , \vec{y} or \vec{A} , \vec{B}).

In this book the physics you will be taught will not involve application of vectors. At best you will be reminded which one is scalar and which one is a vector.

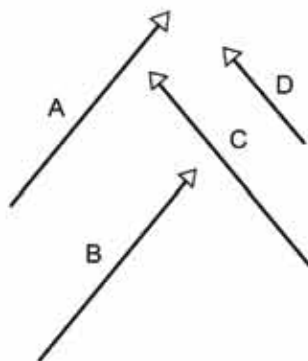

Figure 2.03: Vector A and vector B are equal in all respect although in different position, vector C is different from A and B, because their magnitude is same but direction is different. Vector D is different from C, because direction is same but their magnitude is not same.

2.4 Distance and Displacement

We are quite familiar with the word 'distance' but we do not use the word 'displacement' in our daily life. We want to understand the relation between the two words- distance and displacement with the help of an example. A curved path is shown in figure 2.04. The distance travelled with respect to the point A is denoted by the number 1, 2, 3 in kilometer.

Let us consider you are at point A (i.e. your position is point A). Now you have reached point B by 4 km way by riding a bicycle along the curved path. We can say the distance between point A and point B is 4 km. Distance is a scalar quantity, so to express the distance between the points A and B we need not mention any direction. We determined the 'distance' of the point B along this path with respect to the point A. Now if we desire, we can determine the 'displacement' of point B with respect to point A. By displacement the position of point B with respect to point A is meant.

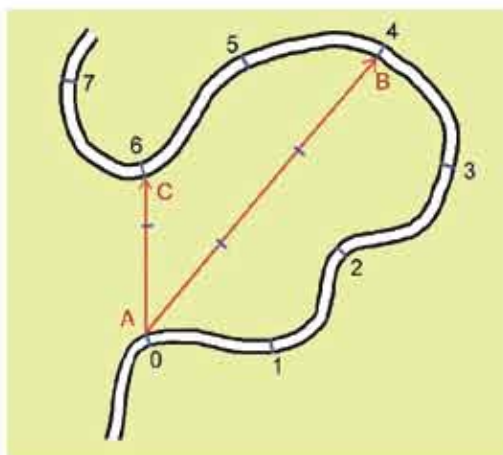

Figure 2.04 : Curved path travelled by a cycle from point A.

In the figure the displacement is shown by a straight line from point A to point B with an arrowhead. In this figure the magnitude of the displacement is 3 km and the direction of the arrow is in the direction of the displacement. Therefore displacement is a vector quantity; it has both magnitude and direction.

If going two kilometers more by a cycle you cross a six kilometer path total and reach point C, then your displacement will be the straight line AC with an arrow, whose magnitude is 1.5 kilometer and the direction of the arrow is along your displacement. Though you covered more distance along the curved path but your displacement is still small. Therefore the more distance you cover, the more will be the displacement is not true. The difference between the initial and final position is the displacement.

Starting from the point A, the distance towards point B is 4 km along the curved path, similarly the distance between point B and point A is 4 km i.e. both are equal. But notice that the displacement from A to B and the

displacement from B to A are not equal. One is negative of the other. In vector form we can write,

$$\vec{AB} = -\vec{BA}$$

Distance or displacement, both have the dimension of length.

$$[\text{Displacement}] = L \text{ (vector)}$$

$$[\text{Distance}] = L \text{ (scalar)}$$

2.5 Speed and Velocity

Roughly we know what is meant by velocity. The measurement of how fast a body is moving is called the velocity. In physics, velocity has a definite meaning and in addition to velocity we use another quantity named speed. If we have understood the two terms distance and displacement properly, then we will be able to understand two terms speed and velocity very easily.

Speed is the rate of change of distance with respect to time. Therefore, if you have covered 100 m distance in 20 second, your speed will be;

$$v = \frac{100 \text{ m}}{20 \text{ s}} = 5 \text{ m/s}$$

$$\text{The dimension of speed } [v] = LT^{-1}$$

Velocity is the rate of change of displacement with respect to time. Therefore, if the change of your position along a certain direction is 50 m in 20 second, then magnitude of your velocity will be;

$$v = \frac{50 \text{ m}}{20 \text{ s}} = 2.5 \text{ m/s}$$

As velocity is a vector quantity, we will have to fix its direction.

$$\text{The dimension of velocity } [v] = LT^{-1}$$

Here, one thing has to be noticed. If we consider only linear motion, then there is no difference between velocity and speed, the magnitude of velocity is the

speed. In this book, we shall consider only the linear motion, so we will not find any difference between speed and velocity. So to understand the internal relationship between speed and velocity, some examples beyond linear motion is discussed:

To explain distance and displacement we considered a curved path in figure 2.04 and showed different positions in that path. To have an understanding about speed and velocity, we can consider the same example. But now we have to tell how much time you have taken for going from one position to another. Suppose you have taken 20 minutes for coming from position A to B by cycle. Then your average speed will be:

Average speed = distance travelled/time

Therefore,

$$v = \frac{4 \text{ km}}{20 \text{ minutes}} = \frac{4 \times 1000 \text{ m}}{20 \times 60 \text{ s}} = 3.33 \text{ m/s}$$

Notice that, we have used the word average speed instead of the word speed. Because, while you are riding the cycle, sometimes you rode fast and sometimes you rode slow. So we cannot talk about the ‘instantaneous’ speed, rather we can talk about the average speed in the time interval.

Let us try to determine velocity now. Like speed, we cannot calculate instantaneous velocity. In this time interval, you rode the cycle at different velocities. The velocity has changed due to the motion being fast or slow. Again the velocity has changed due to the change of direction. Considering these changes, the magnitude of the average velocity will be:

Average velocity = displacement/time

Therefore,

$$v = \frac{3 \text{ km}}{20 \text{ minutes}} = \frac{3 \times 1000 \text{ m}}{20 \times 60 \text{ s}} = 2.5 \text{ m/s}$$

In this example you have noticed that the value of the average velocity is less than that of the average speed. If the path was straight rather than curved, then the magnitude of the average velocity would be equal to the magnitude of the average speed.

In our example, if you rode your cycle always at the same speed then we say your speed is uniform speed. When anything moves with uniform speed then its instantaneous speed and average speed will be the same.

Notice that, since the path is curved, if you go through this path your direction is changing continuously. Therefore you can move with uniform speed through this path but you cannot go with uniform velocity. If anything moves in a linear motion along a straight line, only then uniform velocity or constant velocity is possible.



Example

Question: Let us consider another example to understand the relation between velocity and speed more clearly. Tie a small piece of stone with a string and rotate it around head (figure 2.05). Does the stone move with uniform velocity or with uniform speed? Or with uniform speed and uniform velocity?

Answer: If you think for a while you will be able to understand that the speed of the stone is not changing but the velocity is changing at every instant! Because at every instant the direction of motion of the stone is changing. If the stone moves along a straight line, then the direction of its motion will not change. Since it is revolving, its direction of motion is changing continuously. So it is an example of uniform speed- not of uniform velocity. If it is uniform velocity, then it must be uniform speed. Whereas for uniform speed it is not guaranteed that the velocity will be uniform.



Figure 2.05 : In case of rotation of a stone tied with string, velocity might be changed though speed is same.

Question: If the stone is suddenly released, will it move with uniform velocity and with uniform speed?

Answer: If the stone is released suddenly, it will move straight with uniform velocity and uniform speed. It will continue to move with uniform velocity and uniform speed if there is no air friction or gravitational force etc.

2.6 Acceleration and Deceleration or Retardation

When an object moves with uniform velocity it has no acceleration. If there is a change of velocity, then there is an acceleration. More clearly, we can say, the rate of change of velocity with time is acceleration.

Since velocity has both magnitude and direction, the change of velocity can occur in two ways. In our previous example, when you rode (your bicycle along the curved path, the change of velocity occurred at every turn and you are accelerated. Although you travelled the whole path with uniform speed, acceleration took place due to change of direction only. If you tied a stone with a string, as in the previous example, and rotated it over your head with uniform speed then the rotating stone would change its direction of motion continuously. That is, change of velocity will occur and acceleration will take place.

If your motion is linear, then there is no scope of changing the direction. Then acceleration may occur only for the change of magnitude of the velocities (speed). When the magnitude of the velocity increases, then we can say acceleration is taking place along the direction of the velocity. If the velocity decreases, then we can say negative acceleration or deceleration is taking place. Now we can determine the acceleration of an object moving along a straight line.



Example

Question: In figure 2.06 the change of velocity of an object with time is shown. Identify where there is acceleration and where it is absent.

Answer: There is acceleration at A; at B there is no acceleration. At C, there is acceleration; at D there is negative acceleration or deceleration.

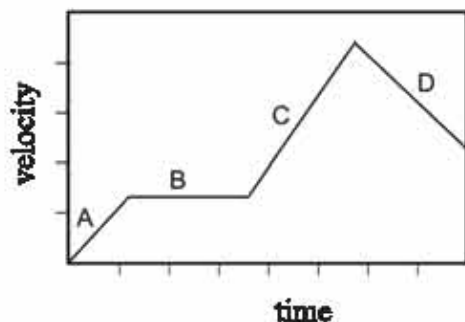

Figure 2.06: Change of velocity of an object with time

In this chapter we will discuss only the linear motion i.e. if the change in magnitude of the velocity occurs then only acceleration will take place.

Acceleration is the rate of change of velocity with time. If the acceleration is uniform i.e. it will not change with time, then we can write;

$$\text{acceleration} = \frac{(\text{final velocity} - \text{initial velocity})}{\text{time}}$$

If the initial velocity of an object is u and after time t the velocity becomes v , then the acceleration a will be;

$$a = \frac{v - u}{t}$$

The dimension of acceleration: $[a] = LT^{-2}$

Unit of acceleration: ms^{-2}

When the acceleration a is known and if the initial velocity is u then after time t it is very easy to find the final velocity v (Figure 2.07). The final velocity is,

$$v = u + at$$

If the object starts its motion from rest, then

$$v = at$$

In the meantime all the discussions done so far are true for uniform acceleration. If the object does not move with uniform acceleration, then it is not so easy to find the acceleration from the initial and final velocities.

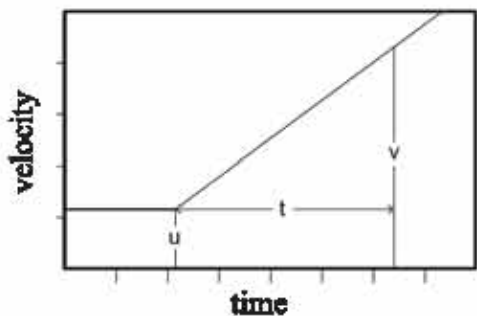

Figure 2.07 : Increasing velocity of an object which is moving with uniform acceleration, started from rest.

The examples of motion we see around us, such as the motion of a car, train or a bicycle etc. have their accelerations as non-uniform almost all the time. For example, if a car starts its motion from rest and increases its velocity gradually, then starting from zero its acceleration reaches a particular value. When the car attains its peak velocity, then its velocity does not increase any further and the acceleration becomes zero again. If the car reduces its velocity and ceases it

motion, then retardation starts. If the car ceases its motion, then both its velocity and acceleration become zero. You may think that the examples of uniform acceleration are rare.

There is an amazing example of uniform acceleration which we see in our surroundings. That is the acceleration due to gravity. Near the earth's surface, the value of this acceleration is 9.8 ms^{-2} . If we release an object from rest from above the earth, then its velocity increases according to the equation $v = gt$.

2.7 Equations of Motion

Since we discuss only linear motion, the quantities we have talked about so far are:

u : initial velocity

a : acceleration

t : elapsed time

v : velocity after elapsed time

s : distance covered in elapsed time

Almost all the relationship among these quantities, are done already, only one is left, which is the relationship for the distances. If an object has no acceleration, then there is no change in its velocity. Then the initial velocity and the final velocity will be equal i.e. ($u = v$). Therefore the distance covered will be,

$$s = v t$$

If there is uniform acceleration, the final velocity is:

$$v = u + at$$

This equation shows that the velocity is changing with time. Therefore to calculate the travelled distance, velocity at any instant is to be multiplied by the time of that instant and then the total distance, for the elapsed time, determined. For this type of calculation we have to know a special type of mathematics (called calculus), here we will solve it without this mathematics. This will be possible since we are concerned only with uniform acceleration. If it is not uniform acceleration, it would not be possible.

Since the velocity is changing every moment hence we cannot write the equation $s = vt$ but if we consider an average velocity V then we can write

$$s = Vt$$

It means that to calculate the distance travelled we have to find only the average velocity. For uniform acceleration it is easy to find average velocity. If anything increases uniformly then its average value is exactly equal to its mean value. In other words if anything increases uniformly then the arithmetic mean of its initial and final values represents its average value. i.e. ,

$$V = \frac{u + v}{2} = \frac{u + (u + at)}{2}$$

$$V = u + \frac{1}{2}at$$

Therefore the travelled distance is,

$$s = Vt$$

$$s = \left(u + \frac{1}{2}at\right)t$$

$$s = ut + \frac{1}{2}at^2$$

In all the equations of motion we have already deduced the time t is present. We can deduce another equation in which t is absent.

Such as:

$$v = u + at$$

$$v^2 = u^2 + 2uat + a^2t^2 = u^2 + 2a\left(ut + \frac{1}{2}at^2\right)$$

$$v^2 = u^2 + 2as$$

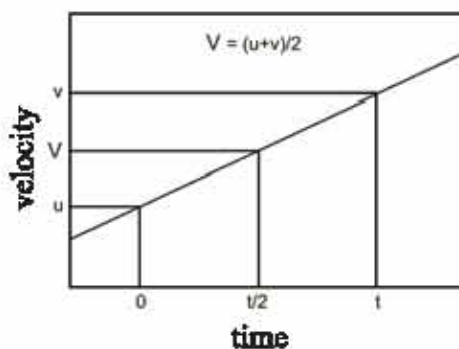

Figure 2.08: Average velocity is the mid time velocity of the initial and final velocity.

Although this equation looks like another general equation, there is some amazing physics hidden in it, which we will reveal in the fourth chapter.



Example

Question: The velocity of a car is increased by 60 km/hour within 1 minute of starting from rest. What is its acceleration?

Answer: From now we will use the unit of time in second (s) instead of minute or hour and for distance meter (m) will be used instead of mile or kilometer.

The final velocity of the car is

$$v = 60 \frac{\text{km}}{\text{hour}} = \frac{60 \times 1000 \text{ m}}{60 \times 60 \text{ s}} = 16.67 \text{ m/s}$$

So the problem is like this, a car attains a velocity of 16.67 m/s in 60 s starting from rest, what is its acceleration?

$$v = at$$

$$a = \frac{v}{t} = \frac{16.67 \text{ m/s}}{60 \text{ s}} = 0.278 \text{ m/s}^2$$

Question: A car is moving with a velocity of 60 mile/hour, suddenly its engine stops. It takes 5 minutes to come at rest. What is the deceleration of the car?

Answer: When there is acceleration, velocity increases; where as velocity decrease of when there is negative acceleration or deceleration.

Again we will use s for time and m for distance.

$$1 \text{ mile} = 1.6 \text{ km} = 1600 \text{ m}$$

Initial velocity of car,

$$u = 60 \frac{\text{miles}}{\text{hour}} = \frac{60 \times 1.6 \times 1000 \text{ m}}{60 \times 60 \text{ s}} = 26.8 \text{ m/s}$$

Final velocity of car, $v = 0$

Acceleration,

$$a = \frac{v - u}{t} = \frac{0 - 26.8 \text{ m/s}}{300 \text{ s}} = -0.089 \text{ m/s}^2$$

Thus the acceleration of the car -0.089 m/s^2 or deceleration 0.089 m/s^2

Question: The velocity of a bullet is 1.5 km/s . It has penetrated 10 cm of a wall. What is the deceleration of the bullet?

Answer: The only way to solve this problem is to use the formula

$$v^2 = u^2 - 2as$$

Final velocity, $v = 0$

$$0 = (1.5 \times 1000)^2 - 2a \left(\frac{10}{100} \right)$$

$$a = \frac{(1.5 \times 1000)^2}{0.2} = 11,250,000 \text{ m/s}^2$$

Deceleration: $11,250,000 \text{ m/s}^2$ (or acceleration: $-11,250,000 \text{ m/s}^2$)

2.8 Laws of Falling Bodies

We have already mentioned that an amazing example of uniform acceleration is acceleration due to gravity g . Due to its effect an object falls downward when it is released from above the earth surface. Observing these types of falling bodies Galileo invented three laws. The laws can be used in case of bodies falling freely. The laws are as follows:

First law: All bodies falling from rest and from the same height without any resistance traverse equal distance in the same time.

Second law: The velocity (v), acquired by a freely falling body from rest in a given time (t) is directly proportional to that time. i.e. $v \propto t$

Third law: The distance (h) traversed by a freely falling body from rest in a given time (t) is directly proportional to the square of the given time. i.e. $h \propto t^2$

We have mentioned earlier that the acceleration due to gravity is an example of uniform acceleration. The equations we have deduced about motion, can be used to deduce the equations of motion of the falling bodies. In case motion s was used to indicate the travelled distance, for a falling body we will use h to indicate height. For acceleration we will use g instead of a . These two will be the only difference!

$$v = u + gt$$

$$h = ut + \frac{1}{2}gt^2$$

$$v^2 = u^2 + 2gh$$

The three laws of falling bodies of Galileo are nothing but these equations of motion of falling bodies.

The first law states that all objects released from the same height will reach the ground at the same time i.e. it does not depend on the mass of the objects. This does not go with the experience of our daily lives. If a piece of paper and a piece of stone are released from the same height, at the same time, then the stone reaches the ground first and the paper reaches the ground later. This happens due to the resistance of air. If the experiment is done in a vacuum tube then both the paper and stone will reach the ground at the same time. Galileo's first law can be understood from the equation of falling bodies. This is because there is no mass of object in the equations of velocity and traversed height. That is the acceleration due to gravity acts equally on both heavy and light objects. So the freely falling body traverses equal distances in the same time.

The second law of Galileo is the law of increase of velocity due to g . If the initial velocity u is zero then velocity v is proportional to g . Galileo's third law is nothing except the equation of h . In this formula if we consider $u = 0$ then we see that traversed distance h is proportional to t^2 .



Example

Question: A good pace bowler of cricket can throw a ball with a velocity of 150km/hour. If he throws the ball vertically upwards, how high will it go?

Answer:

$$150 \text{ km/hour} = \frac{150 \times 1000 \text{ m}}{60 \times 60 \text{ s}} = 41.67 \text{ m/s}$$

Acceleration due to gravity will act as retardation when the ball is thrown vertically upwards. The ball eventually comes to a stop. If the height is expressed by h then,

$$v^2 = u^2 - 2gh$$

$$v = 0, \quad u = 41.67 \text{ m/s}, \quad g = 9.8 \text{ m/s}^2$$

Therefore,

$$h = \frac{u^2}{2g} = \frac{(41.67)^2}{2 \times 9.8} \text{ m} = 88.59 \text{ m}$$

[The ball will approximately reach the roof of a 30 storied building]

Question: When a space ship revolves round the earth then its speed is very high and is nearly 10 km/s. If a cannon ball is fired at this velocity straight upward, how high will it go?

Answer: Let us try like with the cricket ball, only the initial velocity will be 10,000 m/s instead of 41.67 m/s.

Therefore,

$$h = \frac{(10,000)^2}{2 \times 9.8} \text{ m} = 5,102,000 \text{ m} = 5,102 \text{ km}$$

Though it is felt that there is no mistake anywhere but actually the answer is not correct. This is because we have considered the value of acceleration due to gravity is 9.8 m/s^2 , this is true for the distances near the surface of earth. But if we go far from the earth the value of g will decrease. When we deduced the equation

$$v^2 = u^2 - 2gh$$

then we considered that the value of g is not changing. It is not true for this problem. So what we have learned till now, that knowledge cannot be used to solve this problem. If we cannot solve it, there will be no loss; because if anything is thrown upwards with this high velocity it will be burnt due to air friction!



Do yourself

Determination of velocity and acceleration at any time from a time-distance graph.

(Motion and Graph)

We have deduced equations of motion in the previous sections. We have analyzed the relations between distance travelled, velocity and acceleration. In this section we will analyze the same quantities but only by graph. We can have a kind of real feelings about different quantities of motion, if we analyze them graphically.

Table 2:01

Time (s)	Distance (m)	Time (s)	Distance (m)
0	0	0	0
1	1	2	6
2	4	4	24
3	9	6	54
4	16	8	96
5	25	10	150

We need to mention something here. Whenever we have discussed distances travelled, velocity or acceleration we always considered a standard situation. We considered that when an object moves, there is no friction and the object does not lose its energy by any other means. That does not happen in real life. That is why it is not so easy to collect real data for distances travelled, velocity or acceleration. For performing a real experiment an air track is used in the laboratory, where an object is kept floating in an air layer so that no friction is present. To measure the change of position of an object with respect to time, electric sparks or electronic signals are used. We will not get such type of data in our daily lives easily. For now we will consider that we have collected some data in this standard situation, to use in our graph. Two sets of data have been shown in the table

2.01 which represents the change of position of an object with respect to time. We will solve the first set for you and you will solve the second one by yourself.

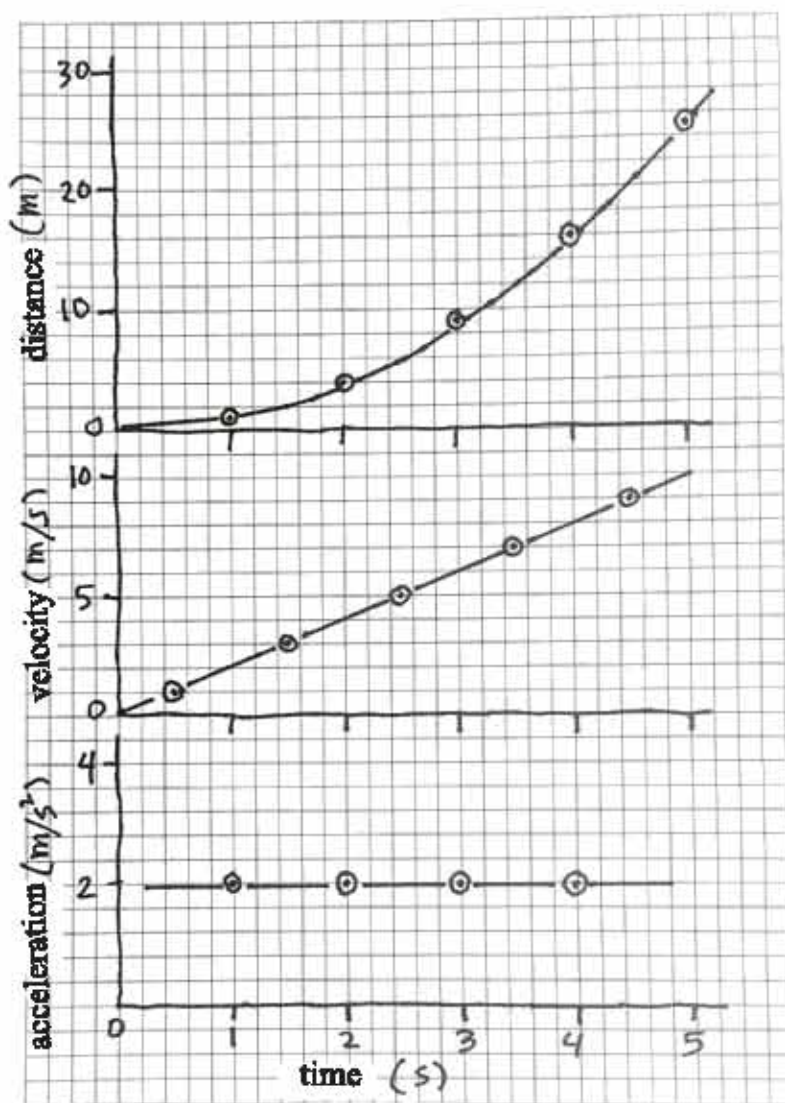

Figure 2.09: Finding velocity - time from distance - time and acceleration - time from velocity-time graphs are drawn.

The distance – time graph of the first data set of the table is shown in figure 2.09. We have taken data in integer form. From the graph we will be able to

find the distance of any time from 0 to 5s. For example the distance of the object in 2.5 second is approximately 6.25m. If we have a velocity versus time graph, from there we can find the velocity easily. Velocity of an object is the rate of change of its position. So we can see from the graph the object has travelled a distance of 0 m to 1 m in 0 to 1 second. Therefore the average velocity at this time,

$$v = \frac{(1 - 0) \text{ m}}{1 \text{ s}} = 1 \text{ m/s}$$

We can use this average velocity for the mid-time value of 0 to 1s. Similarly the average velocity within 1 to 2s is,

$$v = \frac{(4 - 1) \text{ m}}{(2 - 1) \text{ s}} = 3 \text{ m/s}$$

We can use this velocity as data for the time 1.5 s within 1 to 2s. Similarly we see the average velocity between 2 s and 3 s is 5 m/s, between 3 and 4 s is 7 m/s and between 4 s and 5 s is 9 m/s. We see these data points are on a straight line on a graph paper and we can connect the points by drawing a straight line. Although we have put the data for time 0.5, 1.5, 2.5, 3.5 and 4.5 s, but we can find the velocity at any time after drawing a straight line through these points. For example at time 3 s the velocity is 6 m/s.

We will be able to find the acceleration in the same way after drawing the velocity -time graph of figure 2.09. Acceleration is the rate of change of velocity. Since the velocity- time graph is a straight line, so in this case we will get the same value of the acceleration at any point on the graph. For example the rate of change of velocity in between the time 2 s to 3 s is,

$$a = \frac{(6 - 4) \text{ m/s}}{(3 - 2) \text{ s}} = 2 \text{ m/s}^2$$

For any other time if we calculate the acceleration, the same value will be found. It is shown in the acceleration- time graph in figure 2.09.

Therefore, you have seen that we have found velocity or acceleration at any time starting from the distance- time graph. To more accurately we draw this graph, the more precisely we calculate those quantities. Now, use the second set to calculate velocity and acceleration from graph.



Investigation 2.01

Determination of the average speed of an object rolling over a slanting plank.

Objective: To determine the speed for the same distance travelled on different slopes and then to find relation with slope with the help of graph.

Apparatus:

1. A plane plank or bench or table.
2. A ruler or meter scale.
3. A marble or a cylindrical pen or a pencil which can roll.

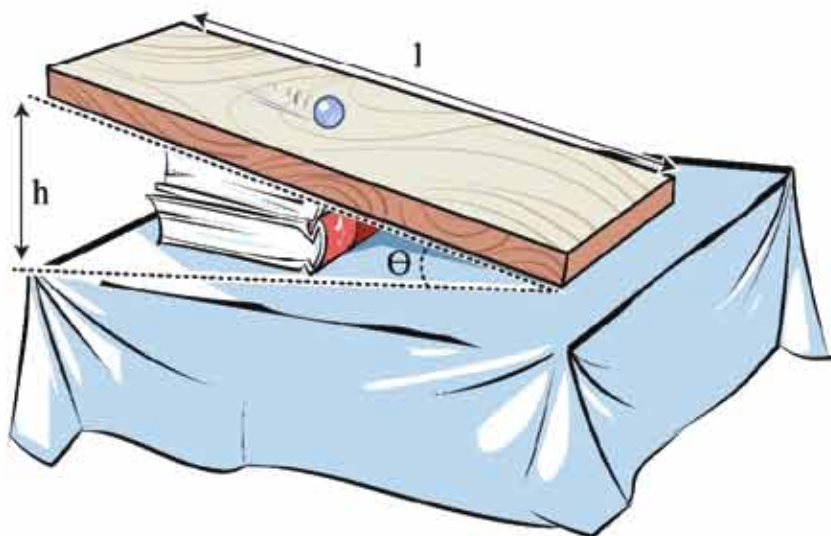

Figure 2.10: A marble is allowed to roll on an inclined plane.

Procedure:

1. Taking a plank or a bench or a table, measure its length (L) by a ruler or meter scale. This distance will be the distance travelled by the object.

2. By placing a book under one end of the plane plank or bench or table let us make it inclined. Measure the height (h) of the book. Dividing height by length, find the slope ($\sin\theta = h/L$).

3. Put a marble or a pencil or a pen on the inclined plane and make sure that it can roll.

4. You have to measure the time taken by the marble to travel the length of the inclined plane. A stop watch is needed to measure the time accurately. But it is unlikely to have a stop watch available. (Now a days stop watch option is available in many mobile phones. You use the method given below). If you have a normal watch instead of a stop watch, you will be at a disadvantage. Because normal watch cannot measure less than a second. We need to measure more accurately. If we have no stop watch, we can try to measure the time by other means. How many numbers (one, two, three,.....) can you count in fifteen seconds at normal speed?

Let us consider if you count up to forty five in fifteen seconds, then we can assume to utter every number in approximately $15/45 = 1/3$ second.

Let the marble or pencil or pen move on the inclined plane and start counting one, two, three and so on. Up to which number could you count for the the marble, pencil or pen to reach the lower end of the inclined plane. Calculate the actual time by multiplying with the approximate multiple.

5. Repeat the experiment several times and calculate the average time.

6. Calculate the speed, dividing the length of inclined plane by the average time. This is average speed.

7. Increase the slope of the inclined plane by placing another book. Measure the new height after placing the second book. Calculate the slope for this height.

8. Let the marble, pencil or pen roll on the inclined plane again. Measure the time by counting the numbers and calculate the speed again. Increase the slope gradually and calculate the average speed every time.

9. Draw a graph by plotting $\sin\theta$ along the X-axis and average speed along Y-axis. From the graph calculate the speed for any slope.

No. of Readings	Distance L cm	Height h cm	$\sin\theta =$ h/L	Time t s	Speed = $\frac{\text{Distance}}{\text{Time}}$ m/s	Average speed m/s
1						
2						
3						
1						
2						
3						
1						
2						
3						

Discussion: Describe the relation between slope and speed?

Discuss what necessary measures should be taken to perform the experiment with more accuracy?



Investigation 2.02

Playing with different kinds of motion.

Objective: To find the differences among different kinds of motion through games.

Requirement : Small open space.

Procedure:

1. You have to select definite activities to explain different kinds of motion.

Linear motion: You have to run straight, if you face any obstructions you have to turn back and go straight again.

Rotational motion: Spreading your hands on two sides starts rotating.

Translatory motion: Looking in a particular direction move back and forth and left and right.

Periodic motion: You have to run along a circular path.

Oscillatory motion: Raise your hands and oscillate them left and right.

- Those who are interested in playing this game will stand scattered around the room.
- An instructor will loudly say the words linear, rotational, translatory, periodic or oscillatory motion.
- Everyone has to perform the activities of the game as instructed by the instructor. Those who will fail to follow the instructions will be knocked out.
- The instructor of the game will utter different motions at different times and the boys and girls have to act out that motion.

The person who will be able to demonstrate all kinds of motion perfectly, he or she will be declared the winner.

Keeping the fundamental characteristics of the motions unchanged, the activities of different motions can be changed as necessary. For example, the instructions may be given to demonstrate two different motions at the same time. In case of linear and oscillatory motion the participant have to run straight by oscillating his or her hands left and right.

Discussion: Write down some additional names of different motions which can be demonstrated.



Investigation 2.03

To determine the speed of moving vehicles.

Objective: Determination of speed of different kinds of vehicles by measuring the distances travelled at different times.

Apparatus: Ruler.

Working Procedure:

- To determine the speed of a vehicle, at first you have to measure the distance between two stationary objects beside a road (e.g. light post, Tree, shop etc). Measurement of distance very accurately may be complex that's why we will use a simple way to do it. At first you have to measure the distance of your step by a ruler. (Measure the distance of ten steps and divide it by ten to make it accurate).

2. Now walk from one stationary object to another object on road sides. Count the number of steps you need to travel the distance and multiply it by the distance of your single step to calculate the distance. It will be better if the distance is approximately hundred meters.

3. Now try to measure the speed of a bicycle, rickshaw, tempo or a pedestrian staying at a safe distance beside the road. Since the distance is known, you can measure the required time, then speed can be calculated.

4. To measure the time accurately a stop watch is required, or an ordinary watch will meet up the purpose instead of a stop watch. If you have none, you can use an easy method to measure the time. It takes almost one second to utter the words “one thousand one”, “one thousand two”, “one thousand three” etc. Counting like this we can measure it.

5. When you will see a cycle, rickshaw, tempo or a pedestrian just passing the first stationary object, you start to count time with a watch, or start counting “one thousand one”, “one thousand two” and so on. Again when you will see this vehicle just passing the second stationary object, you see the time on the watch or stop counting the numbers. Find the required time from the watch or up to which number of words you have counted, This is the time to travel the distance.

Calculate the speed dividing the distance by the time.

Discussion: Compose your procedure of measuring time with the time of a watch and see how accurate is it. Guess the percentage of error of your calculated speed considering the degree of accuracy of your step measuring procedure.

Vehicles	No. of steps	Distanced travelled L (m)	Time t (s)	Average speed = L/t (m/s)



Exercise



General questions

1. Velocity is zero but acceleration is not zero – is it possible? If possible, explain.
2. Velocity is changing but speed is not changing. Is it possible? If possible show it.
3. The acceleration due to gravity on the moon is 6 times less than that of earth. If a stone is released from a definite height towards earth, at which velocity it will hit the ground, if the same stone is released from the same height.
4. Is there any place from where you go 1 km south and then 1 km east, continuing 1 km north will you reach the same place?
5. Do we travel double the distance at double the time in case of uniform acceleration?



Mathematical question

1. From your school a car has gone 40 km east, then 40 km north, then 30 km west, then 30 km south, then 20 km east, then 20 km north, then 10 km west, then 10 km south. In which direction and how far is the car from your school?
2. Show when velocity and acceleration become positive, negative or zero on the portions OA, AB, BC and CD in figure 2.11.
3. If position is plotted along the Y- axis instead of velocity then what would be the value of velocity and acceleration on the portions OA, AB, BC and CD in the figure 2.11.
4. The velocity of a car is 30 km/hour, after 1 minute the velocity of the car becomes 50 km/hour with uniform acceleration. What is the distance travelled by the car in this time?
5. You have thrown a ball vertically upwards at 10 m/s. How much height will it attain in what time?



Multiple choice questions

Put the tick (\checkmark) mark on the correct answer

- What is the unit of acceleration?
 - ms^{-1}
 - ms^{-2}
 - NS
 - kgs^{-2}
- What type of motion do the hands of a clock have?
 - linear motion
 - elliptical motion
 - periodic motion
 - vibratory motion

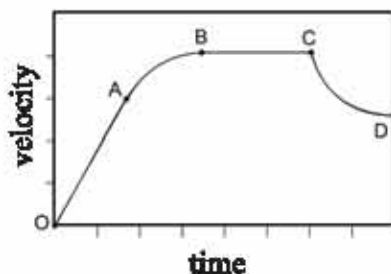

Figure 2.11

- The distance traveled in a given time by a freely falling body from rest will be
 - proportional to the time
 - proportional to the square of that time
 - Inversely proportional to that time
 - Inversely proportional to the square of that time
- A body moves with a uniform acceleration starting from rest. What will be the distance travelled by the body at a given time?

$$(i) \quad s = \frac{(u+v)}{2} t$$

$$(ii) \quad s = ut + \frac{1}{2} at^2$$

$$(iii) \quad s^2 = u + 2a$$

5. Which of the following is the correct?

- a) i b) ii c) ii & iii d) i, ii & iii

5. Which of the velocity-time graph below represents the graph of a freely falling body?

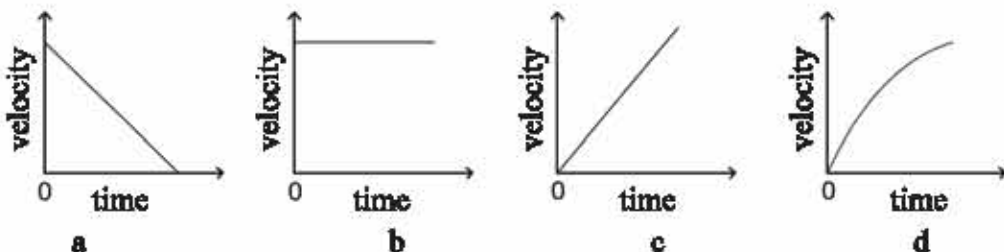

Figure 2.12



Creative question

1. Rajib with his family members started for Jaflong in Sylhet by microbus. He recorded the magnitude of the velocity i.e. speed of the car from the speedometer after every 5 mins throughout the journey. The magnitude of velocity he got per hour was 18,36,54,54,54,36, and 18 kilometer.

- What is instantaneous speed?
- Explain the acceleration of an object moving with uniform velocity.
- Find the distance traveled by the car in the first 5 min.
- Draw and explain the velocity-time graph from the collected data.

2. An object of mass m is moving with an acceleration a . Its initial velocity is u , final velocity v and the distance travelled in time t is s . The state of motion of the object is given in the table:

No. of event	u (m/s)	v (m/s)	t (s)	s (m)	a (m/s ²)
1	10	30	5	-	-
2	5	20	4	44	3

- Define acceleration.
- Why is the acceleration due to gravity the example of uniform acceleration?
- Calculate the value of s for event no.1 in the table.
- Comment on event two through mathematical analytical perspective.

Chapter Three

Force



Weight lifting by South Asian Games gold medal winner
Mabiya Akhter Simanta

We discussed the motion of objects in earlier chapters but the reason behind motion was not discussed. In this chapter we will see that motion is created due to force and will also discuss about three devides laws of Isaac Newton regarding force. At the time of discussion of how force acts on a body, very naturally topics like different types of force, inertia of body, nature of force, frictional force etc come into the discussion.



By the end of this chapter we will be able to-

- explain the inertia of object and the qualitative concept of force by applying Newton's first law of motion.
- explain the nature of fundamental forces.
- explain the influence of balanced and unbalanced forces.
- explain the momentum and collision of objects.
- analyse the influence of force on the motion of an object.
- measure the force by applying Newton's second law of motion.
- explain the action and reaction force by Newton's third law of motion.
- analyse the influence of motion and force on safe travelling.
- explain the conservation laws of momentum and collision.
- explain different types of frictions and frictional forces.
- analyse the influence of friction on the motion of an object.
- describe the means to increase or decrease friction.
- explain the positive impact of friction in our daily lives.

3.1 Inertia and Concept of Force- Newton's First law

In the previous chapter we have learned about velocity, speed, acceleration (and deceleration), elapsed distance and their mutual relationships. We have deduced the equations of motion and applied them to solve problems related to motion as well. In this chapter we will learn how motion can be created or motion can be influenced by applying force. We may begin with Newton's First law.

Newton's First law of motion: Newton's first law of motion can be expressed as-

A stationary object will remain stationary and an object in uniform motion will continue its uniform motion unless a force is applied to it. (Since velocity is a vector quantity, for uniform motion the object will not change its direction of motion; it will move along a straight line at uniform speed.)

The first part of Newton's first law is not difficult to understand because we always observe that the bodies at rest remain at rest and do not move until they are pushed. The problem arises from the second part, because we never observe that a body in motion keeps its perpetual motion for ever. If motion is produced in a body by pushing it, we observe that the body comes to rest if no force is applied. From our daily life experiences it seems that to keep a body in uniform motion we have to apply force on it continuously. From Newton's first law we learnt that it is not true. If a body in uniform velocity stops then we have to realize that force has been applied by some means. Friction, air resistance etc. actually stops a moving body by applying force in the opposite direction. If all these forces could be withdrawn, then we would find that a body in uniform motion keeps its perpetual motion for ever.

3.1.1 Inertia

The characteristic that a stationary body wants to be stationary or a body in motion wants to keep its motion, unless a force is applied, is called inertia. When a car at rest suddenly starts moving we move backwards, this is an example of inertia. The lower part of the body is attached to the car. When the car starts moving, the lower part of the body moves with the car but the upper part of the body is still stationary and tends to remain stationary. So the upper part of the

body move backwards. Since this inertia is due to the tendency of rest, this is called inertia of rest.

When people get down from moving bus, train etc we see they fall down due to the inertia of motion. The whole body of the person in a moving train or bus is in motion. When his or her leg touches the ground, the lower part of his/her body comes to rest, the upper part of the body keeps moving forward due to the inertia of motion. So the person falls down.



Do Yourself

Keep a card on a glass. Place a metal coin on the card and flip the card and displace it. The coin will fall into the glass.

If the term 'inertia' was merely a definition then it would not be taught with so much importance. Actually from the viewpoint of physics, it is a very important topic. Uptill now, we have not uttered the word mass, but to know the motion of an object we have to know its mass. We do not treat a light cycle and a heavy truck coming with the same speed on the same scale. The reason is the difference in mass. But actually what is meant by mass? Often we say 'mass' is a measure of the amount of object. But a more scientific answer is 'mass' is the measure of inertia. (Consider the matter seriously- a very important statement has been made). If a body has a higher inertia, then you have to understand that surely it has higher mass. If inertia is less, then the mass is also less. You definitely observed it that the object with higher mass cannot be displaced by higher amount by the application of an equal amount of force. But a body with less mass can be displaced easily. Or otherwise we can say, if the mass is less the influence of inertia is reduced comparatively.



Example

Question: The two graphs illustrate the values of position and velocity with time in figure 3.01, explain where and for what period force was applied?

Answer: Both the graphs are identical to look, but they contain totally different information.

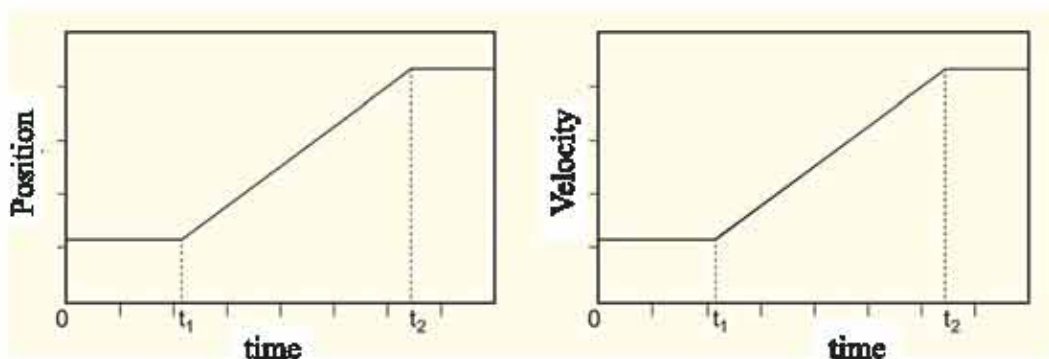

Figure 3.01 : Position-Time and Velocity- Time graph

(i) In the first graph, from 0 to t_1 or from t_2 to the end, there is no change in position in these two time intervals, this means there is no velocity, therefore there is no question of change of velocity. This means definitely no force is acting in these two time intervals. From time t_1 to t_2 , there is a change in position, but the change is at the same rate (since the line is a straight line), that means the object is moving with a uniform velocity. Therefore, there is no change in velocity. Therefore, from time t_1 to t_2 no force is applied on the body. At the instant t_1 , a force is applied on the stationary object to make it move with a uniform velocity. Again just at the instant t_2 , by applying a force the motion is stopped. No force is applied elsewhere.

Therefore, when $0 < t < t_1$, $t_1 < t < t_2$ and $t_2 < t$ there is no force.

Only when, $t = t_1$ and $t = t_2$ force is applied for a moment.

(ii) In the second graph, the object is in uniform motion; from 0 to t_1 and from t_2 to the end, therefore no force is applied on the body during these time intervals. From time t_1 to t_2 , the velocity is changing at a uniform rate, therefore, definitely a force is applied on it.

Therefore, when $0 < t < t_1$ and $t_2 < t$, there is no force.

When, $t_1 < t < t_2$ force is applied.

3.1.2 Force

The word "force" is used for the first time in Newton's first law. But the interesting thing is, it is not yet described what we mean by the word 'force'. If it were a book other than physics then instead of using the word 'application of force' if we use the word 'application of energy', the meaning of the sentence will not be changed significantly. Since it is a book of physics, hence we cannot use the word 'energy' here. In physics, the word 'energy' is a completely different quantity. Here we have to actually use the term 'force'. But what is meant by force? Still now we have not given the definition of force.

Actually Newton's first law of motion can be the definition of force. Force is that quantity the application of which a stationary object start move and a body moving, with a uniform velocity change its velocity. From Newton's first law we can understand, what is force but cannot measure it. But from the second law, we will learn to measure force.

When you use force in your daily life for different purposes, you may realize that for the application of some forces it is necessary to come in contact with the object (e.g. to lift heavy objects with the help of a crane, to push anything or coming to rest of moving objects due to friction). Whereas you may have noticed that for the application of some other forces, it is not necessary to come into contact with the object (falling of anything downwards due to gravitational force, attraction by magnets). So we can divide forces into two types, contact forces and non contact forces. But you definitely understand that the region we assume to touch, but at that region the molecules, atoms and their revolving electrons of each other do not create force by direct touch rather one is working with the other by their electromagnetic forces. In other words we can say, if we go to the atomic scale, then all the forces are non contact in nature. One atom attracts or repulses another atom at a distance; they need not touch practically.

3.2 Nature of Fundamental Forces

If you are asked how many types of forces are there on the earth? You certainly will say, many types. If we push anything this is a force, when a truck carries or pulls a load this is a force, when a tree is uprooted due to a storm this is a force, when a magnet attracts iron this is a force, when houses are blown away in bomb blasts, it is a type of force, it is a force, when a crane lifts something this is force. If you are given some time, you can prepare a big list of such types of forces.

But do you know the amazing matter? There are only four types of forces in nature, if the forces described above are analyzed, you will find that they are not outside these four types. Fundamental forces are actually only four in number. These are; gravitational force, electromagnetic force, weak nuclear force and strong nuclear force.

3.2.1 Gravitational Force

All objects in the universe attract one another by a force due to their mass. This force is called the gravitational force. Due to this gravitational force the stars are revolving within the galaxy or the earth is revolving around the sun and the moon is revolving around the earth. When the force of gravitation of the earth works on us, we call it gravity. This gravity attracts us towards the center of the earth i.e. pulls downwards and due to this pull we feel our weight.

Force of gravitation is an amazing force of physics. An object that has mass attracts another object by the gravitational force. In this chapter, we shall discuss the gravitational force a little bit more in detail.

3.2.2 Electromagnetic Force

We have seen, now and then, that when we comb our hair with a comb it attracts pieces of papers. We have also seen that a magnet attracts or repulses another magnet. Though we think that electric and magnetic forces are different in nature, actually the two forces are identical. They only appear in two forms. Only and this electromagnetic force can attract and repulse but the other forces can attract only, cannot repulse. It is so much stronger than gravitational force (10^{36} times, or trillion trillion trillion times stronger). That the statement is true, you can definitely guess. Because when you comb your hair by a comb and pull a piece of paper by attraction, the whole earth tries to pull the piece of paper by the gravitational force due to its total mass. But the small amount of electricity in your comb defeats the total gravitational pull of the giant earth.

3.2.3 Weak Nuclear Force or Weak Force

It is called weak because it is weaker than the electromagnetic force (approximately trillion times weaker) but not at all weak like the gravitational force. The force of gravitation and the electromagnetic force can act from any distance but this force acts for very small distance (10^{-18} m). The emission of beta (β) rays or electrons from a radioactive nucleus is due to this weak nuclear force.

3.2.4 Strong Nuclear Force

This is the strongest force of the universe; this is hundred times stronger than the electromagnetic force but this too acts at a very small distance (10^{-15} m).

We know the nucleus is situated at the centre of the atom and the strong force acting between the protons and the neutrons within the nucleus confines them. Confined due to this strong nuclear force, the nucleus contains an enormous amount of energy. Therefore by the division of a large nucleus or by the addition of small nuclei a huge amount of energy can be produced due to this force. For this reason a nuclear bomb has so much energy. By this force light and heat is produced in the sun.

According to scientists these four types of forces have the same origin and they are trying to explain all these forces by a single law. Meanwhile, it has become possible to explain the electromagnetic force and the weak nuclear force by a single law. This is a tremendous success of theoretical physics. (Therefore, you can say, forces are of three types: gravitation, electro-weak and nuclear force. Nobody will say it is wrong). The scientists are trying to unify the other forces too by a single law.

3.3 Balanced and Unbalanced Forces

Force is a vector quantity; therefore, if a force is applied on an object then it is possible to cancel that force by the application of another force from opposite direction. Then we say that the forces are balanced. When two or more forces are applied on an object and if the combined resultant force of the forces becomes zero then the body remains stationary.

In figure 3.02 it is shown that an object is suspended with a thread. The force of attraction (i.e. weight of the object) of the earth on the object is acting vertically downwards. Again another force i.e. the tension of the thread is acting vertically upwards. Here two forces are acting in opposite direction thus canceling each other's action and producing a balanced condition.

Now if the thread is cut then the tension of the thread T will not work on the object. Only the force of gravity of the earth or weight will be acting downwards. Here, the force of gravity or weight of the body is the unbalanced force. Owing to this unbalanced force, the object will fall down with the acceleration due to gravity.

We can apply an unbalanced force on the object without cutting the thread too. If by pulling the object we displace it slightly along one side, then the tension of the thread and the weight will not work in the opposite direction. Then the two forces i.e. tension of the thread and weight of the body will combine and produce a resultant force. When the object is just released, this resultant force will start working on the object and the body will oscillate. This is another example of the unbalanced force.

Three forces together can produce the balanced condition too. If a heavy book is tied by a rope and pulled by the two terminals of the rope from two sides, it is possible to suspend the book in a stationary state (Figure 3.03). Since the book is in the stationary state, consequently here the weight of the book W and the two tensions of the rope T_1 and T_2 combine to produce a zero resultant force.

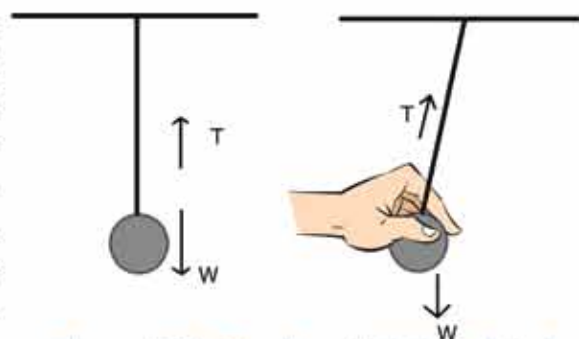

Figure 3.02: The force is balanced in the first figure. In second figure, as soon as the pendulum is released; a resultant force will act, so the pendulum will start movement.

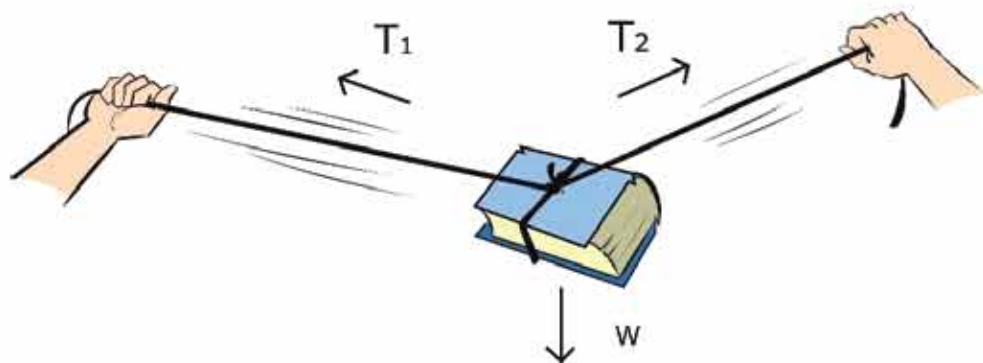

Figure 3.03: No matter how strongly you pull the two ends of the rope, you can never make it completely straight, because then the weight of the book cannot be neutralized.



Do yourself

Tie a heavy book by a rope and try to make it completely straight by pulling it from the two ends. No matter how much force you apply from both ends of the rope, you can never make it completely straight. Because if the rope becomes completely straight then the resultant force cannot be made zero by neutralizing the weight W of the book.

3.4 Momentum

Let a truck and a bicycle hit a small car with the same velocity. In this collision which one will damage the small car more the cycle or truck? Definitely the truck, because the truck is much heavier than the cycle. Though the velocity of the cycle and the truck are the same, but the momentum of the truck is much more than that of the cycle since the truck has greater mass. Simply, the momentum is defined as the product of the mass and the velocity. If the mass of an object is m and its velocity is v then the momentum p can be expressed as:

$$p = mv$$

Here the mass is a scalar quantity, but the velocity is a vector, therefore the momentum is a vector quantity. You may think that generally the mass of an object does not change, so a change in momentum may occur only due to the change in its velocity. But in a special case we may find that the velocity of the object has not changed but due to the change of mass, change of its momentum occurs. You may think, instead of defining a new term 'momentum', what was the problem to always treat it as a product of mass and velocity? In general, it does not create a big problem but in case of a 'particle of light' it may create serious problems. A particle of light or a photon has no mass but it has momentum! Compared to the mass and velocity momentum is a more fundamental quantity.

Unit of momentum is kg m/s

Dimension of momentum is, $[p] = MLT^{-1}$

If more than one object are in motion and they are moving at different velocities,

then they have a combined momentum. Due to different velocities of the objects, they may collide with one another in their path of motion and due to the collisions their velocities may change. If no force is applied from outside, then after the collision the combined momentum will not change. This process is defined as the law of conservation of momentum.



Example

Question: If you throw a tennis ball at a wall with a velocity of 10 m/s, it will bounce back towards you with the same speed. If the mass of the ball is 100 gm, what is the change of momentum?

Answer: when the ball is thrown, then the momentum is $p = mv$. After striking the wall, when the ball bounces back, its momentum becomes $p' = -mv$.

Therefore the change of momentum:

$$p - p' = mv - (-mv) = 2mv$$

For this change of momentum, the wall exerts a force on the tennis ball for a very short time. In cricket, the batsman hits the ball by the bat for a very short interval of time and the change of its momentum occurs. We call these six's or a boundary.

3.5 Collision

3.5.1 Conservation of Momentum and Energy

Let us consider that two objects of masses m_1 and m_2 are moving along a straight line on a plane. Due to the difference of their velocities they collide and hence their velocities are changed. Now, v_1 and v_2 are the new velocities of masses m_1 and m_2 respectively (figure 3.04). Can we find the values of v_1 and v_2 after the collision?

The combined momentum of the two objects before collision = $m_1u_1 + m_2u_2$

The combined momentum of the two objects after collision = $m_1v_1 + m_2v_2$

Since, no force is applied from outside, hence the momentum before collision and after collision will be the same. This is the law of conservation of momentum.

Therefore we can write,

$$m_1 u_1 + m_2 u_2 = m_1 v_1 + m_2 v_2$$

Here we have only one equation and two unknown quantities v_1 and v_2 , therefore we cannot calculate the values of v_1 and v_2 . We need another equation to determine the values of v_1 and v_2 . Fortunately, we have another equation too. In the next chapter, when we will learn about energy, we will get the second equation from the law of conservation of energy. This phenomenon is the law of conservation of energy. In the next chapter you will find that the kinetic energy of an object can be expressed as $\frac{1}{2} m u^2$, where m is the mass and u is the velocity of the object.

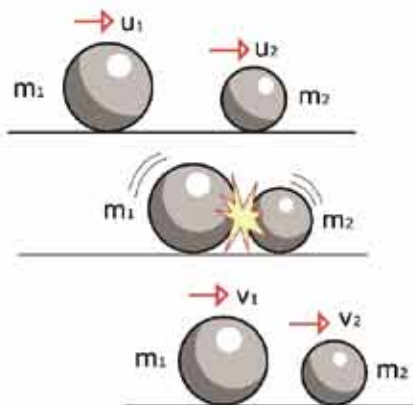

Figure 3.04: After collision, v_1 and v_2 are the new velocities of masses m_1 and m_2 respectively

Therefore using the law of conservation of energy, we can write,

$$\frac{1}{2} m_1 u_1^2 + \frac{1}{2} m_2 u_2^2 = \frac{1}{2} m_1 v_1^2 + \frac{1}{2} m_2 v_2^2$$



Do Yourself

Using these two equations calculate the values of v_1 and v_2 .

We can write the law of conservation of momentum as:

$$m_1(u_1 - v_2) = m_2(v_2 - u_2)$$

The law of conservation of energy, we can be expressed as

$$m_1(u_1^2 - v_1^2) = m_2(v_2^2 - u_2^2)$$

Now using these two equations we can calculate the values of the velocities v_1 and v_2 . These are:

$$v_1 = \frac{(m_1 - m_2)u_1 + 2m_2u_2}{m_1 + m_2}$$

$$v_2 = \frac{(m_2 - m_1)u_2 + 2m_1u_1}{m_1 + m_2}$$

From the expressions of v_1 and v_2 we see that if the masses m_1 and m_2 are equal i.e. $m_1 = m_2$ then the two objects will exchange their velocities.

Then, $v_1 = u_2$ and $v_2 = u_1$



Do Yourself

Right now you can do this experiment. Knock a stationary marble with another marble of the same mass so that it collides with the stationary marble. You will observe that the knocking marble will become stationary and the stationary marble will move with the same velocity as of the knocking marble.

Finding the velocities of two objects after collision and using that concept we will be able to explain the incidents of road accidents easily.

3.5.2 Safe Journey: Force and Motion

In the next chapter we will be able to understand kinetic energy in detail when we will learn about energy. But already we know that the kinetic energy can be expressed by $\frac{1}{2}mu^2$ while reading about collisions. The topic is very important for discussion regarding travelling. The term kinetic energy contains the square of the velocity, this means if the velocity is doubled then energy will increase by four times. When two cars in an accident collide, then due to this energy both cars are damaged and the passengers are injured. Therefore to minimize the loss in an accident, the easiest way is to keep the speed low. In our country, most of the accidents occur due to the speeding of cars. Then it becomes difficult to control the cars and a huge amount of energy is used up when the accident occurs.

Let us consider that a head-on collision occurred between a heavy truck (m_1) loaded with stone and a small car (m_2) coming with the same velocity. Which one will be damaged more?

Since a head-on collision occurred, so velocity of the small car is opposite to that of the truck.

Therefore, if u is the velocity of the truck then the velocity of the car is $-u$. Since, the mass of the small car m_2 is far less than the mass m_1 of the truck, so if m_2 is regarded as zero, the error is not too large and our calculations become easier. (If you desire, you can calculate this by taking the mass of real bus-truck and small

car). Taking m_2 as zero, after collision, the velocity of the truck and the small car is

$$v_1 = \frac{(m_1 - 0)u + 2 \times 0 \times (-u)}{m_1 + 0} = u$$

And

$$v_2 = \frac{(0 - m_1)(-u) + 2m_1u}{m_1 + m_2} = 3u$$

The result is terrible. After the collision, the truck will move with the same velocity, i.e. it will not experience the horrible nature of the collision. The velocity of the small car will be changed from $-u$ to $3u$, that means change of velocity is $3u - (-u) = 4u$, the direction of the velocity of small car will be changed and it will fly off with four times its velocity in the reverse direction. In this process the small car will be crumpled and destroyed. The loss of lives of the passengers will be a very natural consequence.

Therefore, on the roads we have to drive heavy trucks and heavy buses very carefully, because in an accident even though these are not damaged too much, but the small cars are damaged much more in a head-on collision with them.



Do Yourself

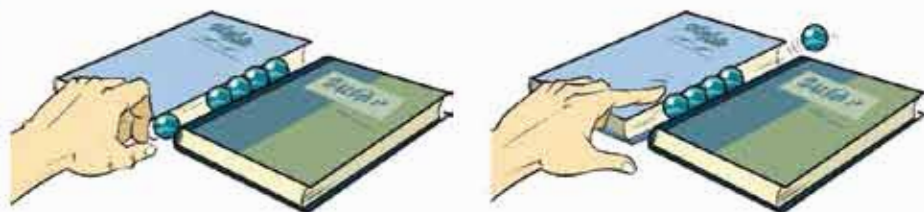

Figure 3.05: Experiment of conservation of momentum and energy

Place two adjacent books parallelly and put four or five marbles in the gaps so that all the marbles are touching one another (Figure 3.05). Hit the row of marbles by knocking with a marble. You will see that if you strike with one marble on one side, one marble will come out from the other side; two marbles will come out if the strike is done with two marbles. You will never be able to bring out two marbles striking with one marble or bring out one marble striking with two marbles.

3.6 Effect of Force on Motion: Newton's Second Law

In the football ground we always see a player kicking a stationary football and directing it to distant places by creating motion. At the time of the kick, when the player touches the ball, only at that instant, force is applied on the ball. The stationary ball goes into motion due to this force.

We can apply force also for a long time instead of just for a moment. By pushing a stationary go-cart for a long time and we can release it after setting it into motion. It can move for a while until it ceases its motion due to friction.

The direction of velocity can also be changed by the application of force. When a bowler throws a cricket ball towards the batsman, then the batsman can direct the ball totally in a different direction by hitting the ball with his bat.

In the three examples given above, we see that velocity is changed by the application of force on an object for a short or a long time. In the previous chapter we have seen that the rate of change of velocity is acceleration. Therefore we can say, when force is applied on an object, acceleration is produced. The relation between the force applied on a body and the acceleration is Newton's second law.

Newton's second law: The rate of change of momentum of a body is proportional to the applied force acting on it and the change of momentum also takes place in the direction in which the force acts.

If a body is moving with an initial velocity u and the velocity is changed (by increasing or decreasing) from u to v after a time t .

The change of momentum:

$$mv - mu$$

So, the rate of change of momentum:

$$\frac{mv - mu}{t} = m \frac{(v - u)}{t} = ma$$

Since, we considered that there is no change of mass, so we can write like this. Further we know that acceleration is:

$$a = \frac{v - u}{t}$$

Therefore if the applied force is F , then we can write Newton's second law of motion as:

$$F \propto ma$$

But we don't want to express the law in proportional form, rather we want to write it as an equation.

In that case, using a proportionality constant k , we can write

$$F = kma$$

In case of Newton's second law it is possible to create an amazing result. Since the term 'force' is not explained anywhere, (Newton's first law gives the concept only) by using the second law this will be measured for the first time. So, we have to give a value for the constant. We can say, when Newton's second law will be applied, if the proportionality constant is considered as 1, then the equation we will get is the measure of force. How easily a proportionality relation is converted into an equation.

Therefore, we can write Newton's second law of motion as an equation. If the force is F and the proportionality constant is considered as 1, then

$$F = ma$$

That this small and simple equation can make a revolutionary change in the world of physics is difficult to believe.

Unit of force is Newton (N).

Dimension of force is $[F] = MLT^{-2}$

We should remember that Newton's second law of motion is true not only for linear motion, but this is true for any type of motion. We have known about gravitational force, by using Newton's second law, we will be able to explain the motion of the planets revolving around the sun due to the gravitational force. But in this book, we will limit the use of Newton's second law only to linear motion. If force is applied on an object, then by using Newton's second law, its acceleration can easily be determined. (If force is divided by mass, acceleration can be found). If acceleration is known, the velocity or distance travelled can be determined by using the laws of motion.

Otherwise we can say that if we see an object in motion and can calculate its acceleration, then if its mass is known, it is possible to calculate the force acting on it.

Now we look at some examples.



Example

Question: A force of 100 N is applied on a stationary body of mass 5 kg for 10 s. (a) what will be the acceleration due to this force? (b) What is the velocity after 10 s? (c) What is the velocity after 20 s? (d) What is distance travelled in 20 s? (e) show velocity and distance travelled by drawing a graph.

Answer: (a) acceleration,

$$a = \frac{F}{m} = \frac{100 \text{ N}}{5 \text{ kg}} = 20 \text{ m/s}^2$$

(b) velocity after 10 s,

$$v = u + at = 0 + 20 \times 10 \text{ m/s} = 200 \text{ m/s}$$

(c) force is applied up to 10 s, since force is applied no more, therefore, after reaching the velocity of 200 m/s, its velocity will be unchanged. That is, velocity after 20 s is 200 m/s.

(d) distance travelled in 20 s has to be determined in two steps. Distance travelled in the first 10 s,

$$s_1 = ut + \frac{1}{2}at^2 = \frac{1}{2} \times 20 \times 10^2 \text{ m} = 1000 \text{ m}$$

Distance travelled in the second 10 s,

$$s_2 = vt = 200 \times 10 \text{ m} = 2000 \text{ m}$$

Total distance travelled,

$$s = s_1 + s_2 = 1000 \text{ m} + 2000 \text{ m} = 3000 \text{ m} = 3 \text{ km}$$

(e) Shown in figure 3.06.

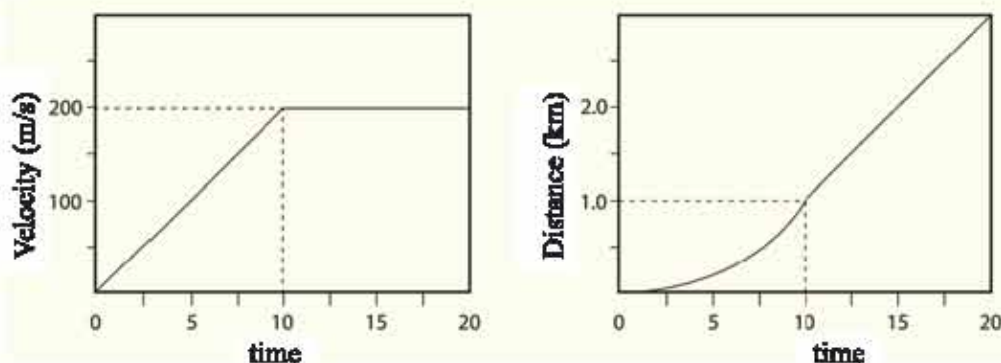

Figure 3.06 : Velocity-Time and Distance-Time graph

Question: A force of 20 N is applied on a stationary object for 10 s and the object covered a distance of 100 m. What is the mass of the object?

Answer: $s = ut + \frac{1}{2}at^2$

Here, $u = 0$

$$a = \frac{2s}{t^2} = \frac{2 \times 100}{10^2} \text{ m/s}^2 = 2 \text{ m/s}^2$$

Again, $F = ma$

$$m = \frac{F}{a} = \frac{20}{2} \text{ kg} = 10 \text{ kg}$$

3.7 Gravitational Force

We have talked about force (which creates acceleration), how it is measured has been discussed (product of mass and acceleration). But until now you have not been introduced to a real force. In physics, an amazing force is the gravitational force; a body having mass attracts another body by the gravitational force. Let us consider two masses m_1 and m_2 and the distance between them is r . Then if the

force (Figure 3.07) acting between them is F , then

$$F = G \frac{m_1 m_2}{r^2}$$

Here, G is the gravitational constant and its value is:

$$6.67 \times 10^{-11} \text{ Nm}^2\text{kg}^{-2}$$

We have to remember that the mass m_1 attracts mass m_2 towards itself by the force F ; also the mass m_2 attracts mass m_1 towards itself.

Of the two masses, if one is our earth and we consider that the mass of the earth is M and we let another body of mass m be kept over the earth's surface, then, the earth will attract the mass m towards its centre by a force F .

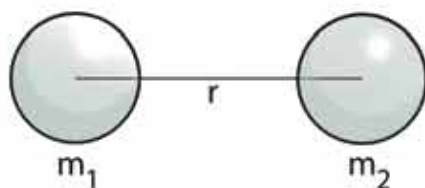

Figure 3.07: Gravitational force between two masses

$$F = G \frac{mM}{R^2}$$

This force is actually the weight of the object. Here, R is the distance of the object of mass m from the centre of the earth. This is not the distance of mass m from the earth's surface. Since the earth radius is too large (approximately 6400 km), therefore the small distances over the earth surface are not considered. The distance is measured from the centre of the earth because for a spherical body if it is considered that all its mass is centered at the centre, then no error occurs. (Because each point of the earth attracts the mass m towards itself and if all the attractions are assembled, it seems that the total mass is concentrated at the centre of the earth!)

The mass m experiences acceleration due to the force of gravitation of the earth. Already we have said that the acceleration due to gravity is expressed by g instead of a .

Therefore instead of $F = ma$ we can write,

$$G \frac{mM}{R^2} = mg$$

$$\text{or, } g = G \frac{M}{R^2}$$

Now, the mass of the earth, $M = 5.98 \times 10^{24}$ kg, radius of the earth, $R = 6.37 \times 10^6$ m,

therefore,

$$g = \frac{GM}{R^2} = \frac{6.67 \times 10^{-11} \times 5.98 \times 10^{24}}{(6.37 \times 10^6)^2} \text{ m/s}^2 = 9.8 \text{ m/s}^2$$

In the previous chapter, we used this value of g in the equations of motion. Now you understand why this value of g was used.



Example

Question: The height of the space station from the earth's surface is approximately 100 km. What is the value of g there?

Answer: In the space station, if the acceleration due to gravity is g' , then

$$g' = \frac{GM}{(R + r)^2}$$

Here, radius of the earth $R=6000$ km, and height of the space station, $r = 100$ km



Figure 3.08: the floating astronaut in a space shuttle

$$g' = \frac{GM}{(R + r)^2} = \frac{GM}{R^2(1 + r/R)^2} = \frac{g}{(1 + r/R)^2}$$

$$g' = \frac{g}{1.016^2} = 9.49 \text{ m/s}^2$$

The value of g' is not zero at all, but why does the astronaut feel weightless (Figure 3.08) there?

If the value of the gravitational acceleration g is known, for any mass m we can calculate the value of gravitational force very easily. This is,

$$F = G \frac{mM}{R^2} = m \frac{GM}{R^2} = mg$$

The gravitational force acting on an object is actually the weight of the object! Therefore, by using a mass we can apply a force on another body. In the figure, due to hanging of a mass M , a force Mg is acting downwards on it. This force is applied on a mass m located on a table by a pulley and a string. According to Newton's second law, the mass m will experience acceleration.

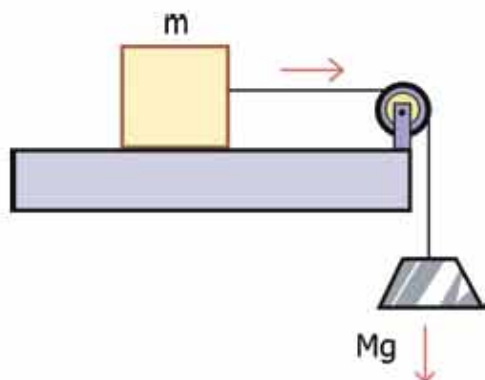

Figure 3.09: Weight of an object is applying force on another object.

Therefore,
$$a = \frac{F}{m} = \frac{Mg}{m}$$

Using this acceleration we can explain the motion of the object located on the table.



Example

Question: As shown in figure 3.10, two weights of masses 10 kg and 5 kg are suspended from two sides of a mass m using two pulleys. What is the force acting on the mass m ?

Answer: 10 kg and 5 kg masses are not a force, these are masses, and therefore by multiplying with g these masses are transformed into forces.

$$10 \text{ kg} \times 9.8 \text{ m/s}^2 = 98 \text{ N}$$

$$5 \text{ kg} \times 9.8 \text{ m/s}^2 = 49 \text{ N}$$

Therefore, the mass m is pulled by 98 N on the left and by 49 N on the right.

Combining the two forces, it can be said that 49 N is acting in the left direction. (On the mass m another force of magnitude mg is acting vertically downwards, but this is neutralized by the reaction force of the table. Very soon you will know how this happens.)

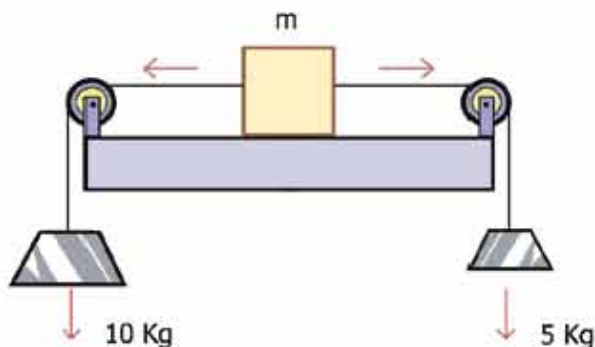

Figure 3.10: Force is acting on a mass by two weights from two sides using pulley.



Do Yourself

Rubber Band Spring Balance

A spring balance is used to measure the weight of small objects. It is less likely that all of you have a spring balance. So, to serve the purpose you can make a spring balance with the help of a rubber band. You can use the plastic lid of a container as a pan to keep a weight. Make four equidistant holes round the pan and tie with a string. Now hang the pan from one end of a rubber band. Attach the other end of the rubber band to a board with the help of a paper clip. Now hang the board in a suitable place.

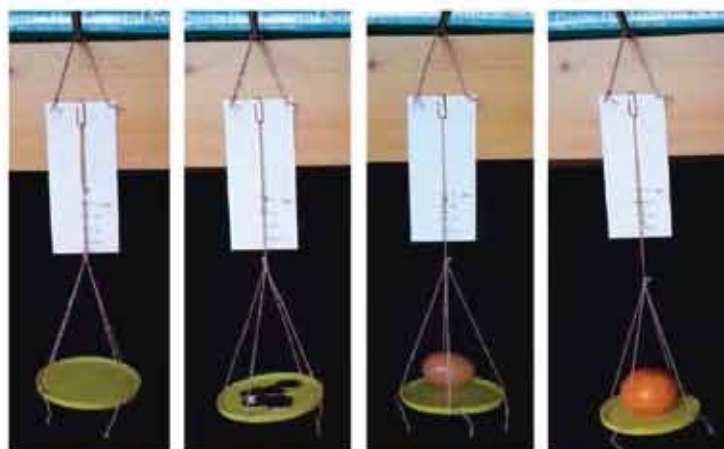

Figure 3.11: A spring balance made of a rubber band

Put a black dot on the string from which you have hanged the pan with the rubber band. When there is no weight on the pan, put a black spot on the board where the black spot of the string remains. This point indicates zero mass. Now put five coins of five taka in the pan. Since mass of each coin is 8 gm, hence total mass will be 40 gm. Then put another black mark on the board where the black spot of the string stays. This indicates mass of 40 gm. Now draw a line from 0 gm to 40 gm marking points and divide the line into four equal parts. Each division equals 10 gm mass. Now increase the length of the line and calibrate it to measure more mass. Divide the line accordingly, as much accurately as you want to measure the mass.

Now your rubber band balance is ready, now with this balance you will be able to measure the mass of small objects around you. If you have an actual

spring balance with you, you can measure the mass more accurately and you can measure the weight from there.

Serial Number	Name of the object	Mass of object obtained from balance in gram, m gm	Mass of object in kg $M = m/1000$ kg	Weight of the object $W = mg$ N

3.8 Newton's Third Law

We have learnt from Newton's first law what happens when no force is applied. We have learnt from Newton's second law what happens when a force is applied. We will learn from Newton's third law what type of reaction takes place between the two objects when an object applies force on another object.

Newton's Third Law: When an object applies a force on another object, then that object also applies a force of equal magnitude on the first object but in the opposite direction.

In physics, generally Newton's third law is written as, "Every action has an equal and opposite reaction", although we have not written it in this form. By this time since we have a little idea about force, confusion may occur if force is termed as "action" or "reaction" "suddenly". Moreover, those who are the new learners of physics, their first question will be if every reaction (a force) has an opposite reaction (another force) then why action and reaction are not cancelling each other, producing zero? For this reason, the third law will have to be written very precisely. The third law states that if there are two objects A and B, then when A exerts a force on B, then B also exerts a force on A. It is worth mentioning that two opposite forces act on different objects, never on a single object. If the two forces were applied on a single object, only then one could cancel the other. Here there is no scope of cancellation.

The matter will be clarified with the help of some examples. Let us consider that a mass m is allowed to fall from a certain height (figure 3.12). We know that due to the earth's gravitational force, the mass m experiences a force F towards the centre of the earth:

$$F = G \frac{mM}{R^2}$$

Already we have seen that this force can be expressed as mg .

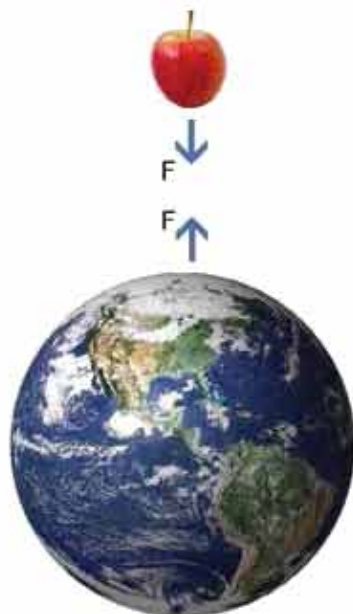

Figure 3.12: As the earth attracts a mass, the mass also attracts the earth in the same manner

From Newton's third law we know that the mass m also attracts the giant earth towards itself. That force is also F , but in the opposite direction. We do not bother about this force, the reason is that the acceleration a of the earth due to this force can be determined:

$$F = Ma$$

Here, M is the mass of the earth and a is the acceleration,

$$\text{Therefore, } a = \frac{F}{M} = \frac{mg}{M} = \left(\frac{m}{M}\right)g$$

If the mass of the earth is $M = 5.98 \times 10^{24} \text{ kg}$, then if an object of mass 1 kg is released from above then the acceleration of the earth will be,

$$a = 1.6 \times 10^{-24} \text{ m/s}^2$$

This is so negligible that nobody is bothered about it! Next time when you jump anywhere, remember that you attract the whole earth towards you when you fall downwards. (As small as the acceleration of the earth may be, you pulled the whole earth towards you, you may be little proud of it!)

The easiest way of understanding Newton's third law is to understand the mechanism of our walking. We can all walk but nobody knows the physics hidden behind this. Since you have started to learn physics a simple question can be put to you. Since you have walked from a stationary position, so you have an acceleration, that means force has been applied on you. But all of us know that nobody is applying a force on us. We walk by ourselves. How is that possible?

Unless we know Newton's third law, we never can explain the mechanism of walking. When we walk, we exert a force on the ground (i.e. apply force). Then according to the Newton's third law the ground also applies an equal and opposite force on our body (Figure 3.13). This equal and opposite force creates the acceleration and we walk.

The persons who have a little problem understanding this, they may be reminded that it is easier walking on hard ground compared to sandy ground. The reason is that it is not possible to apply force on the sand, sand is displaced. Therefore the reaction force in Newton's third law cannot be achieved properly. The matter can be clarified more, if one is allowed to walk on a very smooth surface lubricated with soap-water or oil! There friction is hardly present so we cannot apply a backward force at all and due to this we will not get any force on us as the reaction force. So we cannot walk at all (You may try if you don't believe it). If force is applied, equal and opposite force is found, but if we cannot apply force at all, how can we get a reaction force? Then how can we walk?



Figure 3.13: During walking when a person applies force on the ground then the ground also applies force on him in contrary



Example

Question: Suppose you are standing on a totally frictionless surface. Your mass is 50 kg and there is a stone of mass 100 kg in front of you. You have decided to push the stone with a force of 50 N and will move it from one end to the other. What will be the velocity of the stone after 10 s? (Figure 3.14)



Figure 3.14 : When a person pushes a stone, the stone also pushes the person in return.

Answer: When you push the stone with a force of 50 N, then according to Newton's third law the stone will push you also with a force of 50 N. The acceleration of the stone will take place to the right,

$$a = \frac{F}{m} = \frac{50}{100} \text{ m/s}^2 = 0.5 \text{ m/s}^2$$

Your acceleration will be exactly towards left,

$$a = \frac{F}{m} = \frac{50}{50} \text{ m/s}^2 = 1 \text{ m/s}^2$$

Therefore the stone and you will move in different directions. By pushing the stone you cannot move it from one end to the other. Because a distance will be created between you and the stone. So it is not possible to push the stone nonstop for 10 s. But after the stone starts its movement, it will reach the other end moving by itself on the frictionless surface. You will also reach the opposite end but at an earlier time.

(a) Let us consider you pushed the stone for 2 s, what happens then?

Answer: In 2 s the velocity of the stone will be increased to:

$$v = u + at = 0 + 0.5 \times 2 \text{ m/s} = 1 \text{ m/s}$$

Then the stone will move with a uniform velocity of 1 m/s.

In 2 s your velocity will be:

$$u + at = 0 + 1 \times 2 \text{ m/s} = 2 \text{ m/s}$$

Then you will move in the reverse direction with a uniform velocity of 2 m/s.

3.9 Frictional force

Earlier we have discussed gravitational force or gravity and spring force. Now we shall discuss about a totally different type of force, this is frictional force.

Let us consider a wooden piece on a table and we are trying to create an acceleration by applying a force on it. As shown in figure 3.15, we are applying a force F on the mass from left to right. It will be seen that due to friction between the wooden piece and the table, a frictional force f is developed on the wooden piece and this is lowering the applied force acting from right to left.

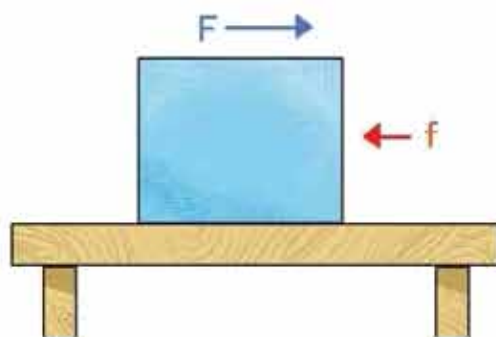

Figure 3.15: If a force is applied on a mass then another force may develop in the reverse direction due to friction.

If you think that due to friction a frictional force is developed from right to left, so if I apply a force on the wooden piece from the left too, then since the applied force and the frictional force are in the same direction, I will get an extra force! But it will be seen that the frictional force is still working in the opposite

direction. The frictional force always works in the direction reverse to that the applied force! If some weight is put on the wooden piece it will be seen that the frictional force is increased also, though the weight and the force of friction are normal to each other.

We will see that there is nothing surprising in it if we understand how frictional forces are developed. Though apparently wood, table etc. (or the two surfaces where friction is present) seem very smooth, but if we view them with a microscope it will be seen (Figure 3.16) that all surfaces are rough or irregular. These rough parts touch one another or the grooves of the two surfaces in contact catch onto one another. The motion is obstructed due to this and we say frictional force is developed in the opposite direction. If the two surfaces are pressed more, then the scratched surfaces make better contact with one another, the grooves of one surface will penetrate into the other's grooves more deeply and as a result the frictional force will be increased.

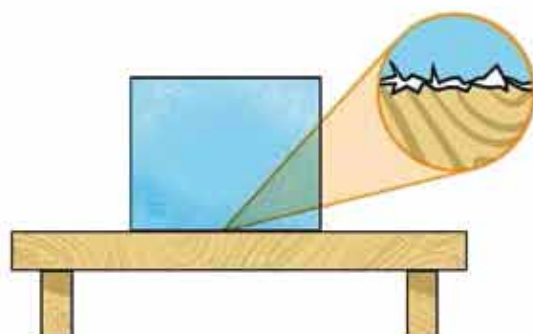

Figure 3.16: Actually friction creates due to two scratched surface.

Due to friction heat is generated. It is a problem in most cases. When a piston in a cylinder moves back and forth in a car, due to friction heat is generated there and to control this heat, the engine of the car needs to be cooled.

3.9.1 Types of Friction

Friction is divided into four types. These are, static friction, sliding friction, rolling friction and fluid friction.

Static friction: The frictional force that develops when two objects are at rest relative to each other is called static friction. Due to static friction we can walk, our legs or shoe soles rub against the ground and we don't slip.

Sliding friction: The frictional force that is create when an object is in motion relative to another object is called sliding friction. When anyone grips the brake

of a cycle, it presses the wheel and ceases the motion of the rotating wheel due to sliding friction. The sliding friction depends on the weight of the moving body, the more the weight, the more the sliding friction. If an object has a mass M , then its weight $W = Mg$ is a force. Then the sliding friction can be written as, $f = \mu W$, μ is the coefficient of sliding friction.

Rolling friction: When an object moves by rolling or revolving on a surface then the friction that develops is called the rolling friction. Among all the frictional forces, this is the least, so we attach wheels on all kind of vehicles. It is very easy to pull suitcases attached with wheels, if suitcases have no wheels, it would become very difficult for us to pull it on the floor.

Fluid friction: The frictional force that is experienced by an object when it moves in a liquid or gaseous substance is called fluid friction. When anyone jumps from a plane with a parachute then due to the fluid friction of air he comes down slowly (Figure 3.17).

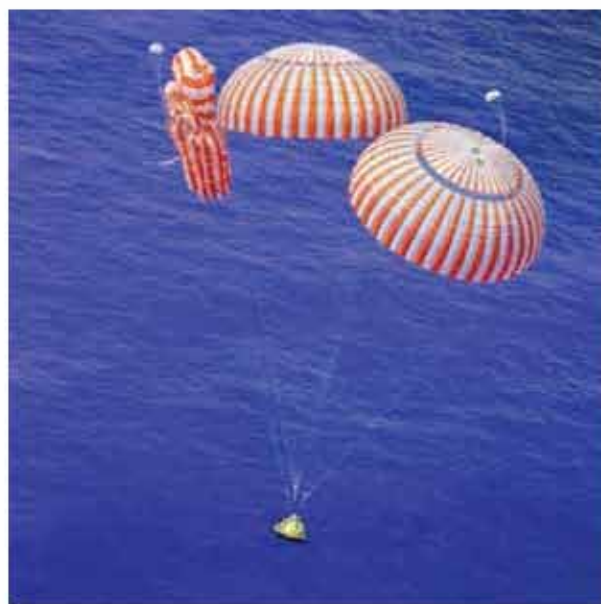

Figure 3.17: Uses of Parachute, Apollo 15 is landing in the sea



Do Yourself

Release a paper from a certain height and guess the time required by the paper to reach the ground. Now shape the paper into a small ball and then release it. What is the time required now to reach the ground? why?



Do Yourself

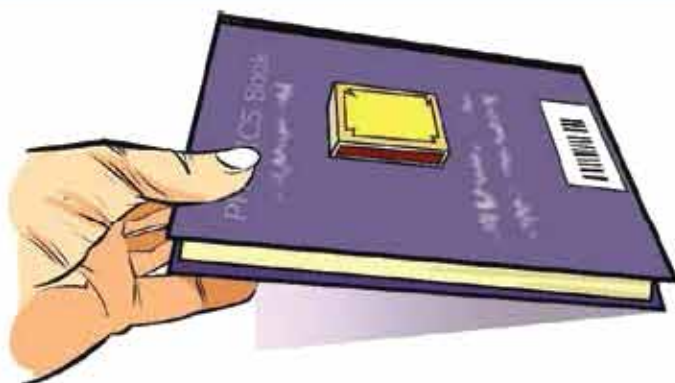

Figure 3.18: Measurement of sliding friction

Static friction and Sliding friction

Take several empty match boxes. Fill up the boxes with soil to make them slightly heavier. Now put a match box on a book and keep sliding the book gradually (Figure 3.18). Due to the static friction the match will not slide at first. When the book becomes sufficiently inclined, then along the slope a force works. At the instant when this force equals the sliding frictional force, then the match box will start sliding. You will see that only for a particular angle of inclination the match will start moving. Putting one or more match boxes over the first one repeat the experiment; you will see that every time for a particular angle the match box will start moving.

3.9.2 Effects of friction on motion

We already discussed that the frictional force always acts opposite to the applied force. Therefore, naturally the frictional force slows down the motion and it may be our assumption that perhaps we always try to reduce the friction. But that is not true. Sometimes you may have seen that a car or a truck is stuck in mud.

Though the wheel of the car rotates but due to less friction, the car or truck cannot come out from the mud. The wheel slides. Then to rescue the car or truck, the friction between the wheel and the mud is increased in an alternate way.

Tyre's Surface: Because of the friction between the car's tyre and the road the car can move on the road. If this friction was not present, then the tyre of the car would slip and the car would not be able to move forward. To increase this friction many types of grooves are designed on the tyre (Figure 3.19). Those who drive cars always give attention to whether the grooves of the car are smooth or flat. If the grooves become flat, then after applying the brakes the car will slip instead of stopping.

Smoothness off road: The roads are specially designed to increase the friction between the tyre of the car and the road.

If the roads are not proper, then the wheels of the cars may skid. After the snowfall, in the cold countries, the roads become very slippery due to ice and the number of accidents increase more than ten times. In our country the friction of the road may decrease due to water logging or due to gravel. All of you have seen pitch carpeted roads, due to this pitch carpeted the friction between the tyre and the road increases. At the same time, the rain water cannot infiltrate into the road and the road can be used for a long time.



Figure 3.19: To increase the friction many types of grooves are designed in the tyre.

Controlling Motion and Breaking Force:

The speed of the vehicle has to increase or decrease according to the necessity when we drive the vehicles. When the speed of the car is low, then it is easier to control it. You can often see that during taking a turn or overtaking another car, the speed of the car is lowered by applying the brakes.

When the driver presses on the brake pedal, this is transferred to the shoe or pad attached to the wheel and the shoe presses down on the disc located inside the wheel. Due to this pressure friction develops between the pad and disc and this frictional force stops the motion of the wheel of the car.

3.9.3 Increase and Decrease of Friction

Already we know that for our necessity sometimes friction has to be increased and sometimes it has to be decreased.

Reducing friction

The measures we may take to reduce friction are:

1. Make the surfaces as smooth as possible where friction is take place. On smooth surfaces sliding friction is less.
2. Oil, Mobil or grease like materials are called greasy materials or lubricants. The friction is reduced to a great extent if lubricants are used in between the two surfaces.

Figure 3.20: Using ball bearing, friction can be reduced to a great extent



Figure 3.20: It is possible to reduce friction by using ball bearings.

3. Using wheel friction can be reduced. If wheel is used we can do work by very small rolling friction instead of large sliding friction. It is possible to reduce friction to a great extent by using ball bearings in the rotating wheel, using the rolling friction of the small steel balls instead of the direct friction.
4. The design of the fast moving vehicles like car, plane is done in such a way that the wind can flow over the streamline surface without creating any friction.
5. The surfaces where friction occurs touch one another in a very small region, then friction can be reduced.
6. We have seen that if force is applied on the two frictional surfaces, friction is increased. Therefore if vertically applied force is reduced, friction can be reduced.

Increasing friction

If the procedures that are taken to reduce friction are not done or if the opposite steps are taken then friction will be increased. Therefore the necessary steps we take to increase the friction are:

1. Roughening the two surfaces where friction is present.

2. Pressing the two surfaces more strongly where friction is present.
3. Make the surfaces stationary by stopping the motion which is present on the two frictional surfaces. Because static friction is more than the sliding friction.
4. Making grooves or waves on the frictional surfaces. Then it can grip the bottom tightly. If there is water or liquid, it enters the grooves thus increasing the friction of the surface.
5. To increase the density of air or water.
6. To increase the frictional area in air or water.
7. To remove wheel or ball bearing.

3.9.4 Friction: A necessary evil

All of us have certainly noticed that heat is generated due to friction. In the winter we create heat by rubbing our hands. The engine of a car becomes hot that happens due to friction. Therefore, energy is dissipated by creating unnecessary heat due to friction. Cars, planes, ships, submarines have to go forward by overcoming the frictional force, requiring extra fuel. If we treat this in this way, it may seem that friction is nothing but an evil in our lives.

Meanwhile, we have seen that due to friction we can walk, drive cars on the road, write on the paper with pencil or pen, construct buildings, come down safely with the help of a parachute. We can give many examples where without friction we could not do our necessary work.

Consequently though friction is treated as an evil, we have to acknowledge that friction is a very necessary evil for our lives.



Exercise



General questions

1. When you try to get down from a moving train why do you fall in the forward direction?
2. As shown in figure 3.21, if a sudden pull is applied on the string A, it will tear. But if it is pulled slowly then the string B will tear. why?

- The object having more mass has more weight or more force. If it is released from above it will have more acceleration, is it true?
- You are standing on a weight measuring machine in a lift. If the cable of the lift tears, what is the weight that shows up on the machine?
- If a stone is tied by a rope and is pulled on a completely frictionless surface towards you, what will happen?
- What is inertia? How many types of inertia are there?
- What is force?
- What is the measure of inertia of a stationary object?
- What do you mean by balanced and unbalanced forces?
- What is momentum of a body?
- Show that, $\text{force} = \text{mass} \times \text{acceleration}$
- What do you mean by law of conservation of momentum?
- What is friction? Write down the names of the different types of friction
- Friction is a necessary evil- give argument in favor of this.

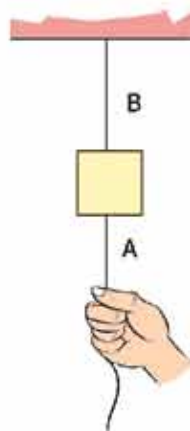

Figure 3.21: Two string attached with a mass



Mathematical questions

- The velocity–time graph of an object of mass 1 kg is shown in figure 3.22. Draw the velocity–time graph.
- A force of 10 N acts on a stationary body of mass 5 kg for 2 s. After 5 s another force of 20 N acts on it for 3 s. What is the distance travelled by the object?

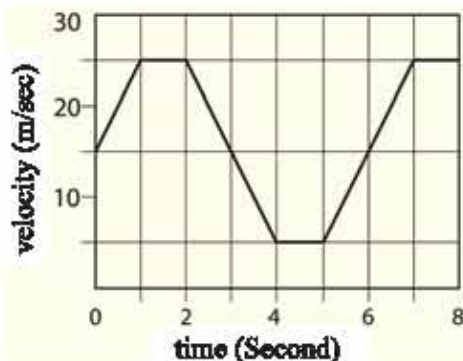

Figure 3.22: Velocity-time graph.

- A force of 10 N acts on a stationary object of mass 10 kg. After 10 s a force of 20 N acts on it for 5 s in the opposite direction. What is the distance traveled by the object?
- You have jumped from a boat with a velocity of 10 m/s towards the bank. Your mass and the mass of the boat are 50 kg and 100 kg respectively. In which direction and with what velocity will the boat move?
- The coefficient of friction μ of a wooden piece on a floor is 0.01. If the mass of the wooden piece is 10 kg, what is the force required in moving it? If a stone of mass 100 kg is kept on the wooden block, what is force required to move it? What happens if the floor is frictionless?



Multiple choice questions

Put the tick (\checkmark) mark on the correct answer

- The tendency or property of a body to maintain its present state for ever is called:
(a) force (b) acceleration
(c) inertia (d) velocity
- Which one is the dimension of force?
(a) MLT^2 (b) MLT^{-1}
(c) $ML^{-2}T^2$ (d) $M^{-1}LT^2$
- Which one is the unit of momentum?
(a) kg m (b) $kg\ ms^{-1}$
(c) $kg\ m^2s^{-1}$ (d) $kg\ ms^{-2}$
- A force of 50 N is applied on a body of mass 5 kg, its acceleration will be-
(a) $12\ ms^{-2}$ (b) $8\ ms^{-2}$
(c) $13\ ms^{-2}$ (d) $10\ ms^{-2}$
- If a mass of 10 kg moves with a velocity of $10\ ms^{-1}$, its momentum will be-
(a) $10\ kg\ ms^{-1}$ (b) $120\ kg\ ms^{-1}$
(c) $100\ kg\ ms^{-1}$ (d) $1\ kg\ ms^{-1}$



Creative questions

1. Faruque pulls a box of mass 4 kg on the floor with a constant force. The frictional force between the box and the floor is 1.5 N. While pulling, the box accelerates at 0.8 ms^{-2} . Then the box is pulled with the same force on a frictionless floor.

 - (a) What is a balanced force?
 - (b) Why is the frictional force generated?
 - (c) What is the force applied to the box in the first case?
 - (d) What is the change in acceleration in frictional and frictionless floors? Explain mathematically.
2. An object of mass 5 kg moving in linear motion with a velocity of 5 m/s hits another object and changes the momentum of the second object by an amount 4 kg m/s. The masses of both objects remain unchanged after the collision.

 - (a) Which property of matter is a measure of inertia?
 - (b) What do you mean by the statement 'The applied force is proportional to the change of momentum'?
 - (c) What is the final velocity of the first object?
 - (d) When there is no change in momentum, then comment about the second object by mathematical analysis.

Chapter Four

Work, Power and Energy



Proposed Rooppur Nuclear Energy Center

In this chapter we will see how force works. In terms of physics the word "work" has a specific meaning. We will see that a force working on something can move it and create kinetic energy. This kinetic energy can convert into potential energy and this transformation of energy is a very natural process and different types of energy can convert into one another.

One of the important aspect of science is energy and energy plays a most important role for the development of mankind. So, how energy can be explored from nature will also be discussed.



By the end of this chapter we will be able to-

- explain the relation between work and energy.
- establish the relation among work, force and displacement.
- explain kinetic and potential energy.
- explain the transformation of energy source.
- analyse the contribution of the source of energy regarding economics, social and environmental influences.
- explain the relation between transformation of energy and conservation of energy.
- explain transformation of energy and how its use hampers the balance of environment.
- explain the effective use of energy in developing activities.
- be conscious about the effective and safe use of energy.
- explain the mass-energy relation.
- establish the relation between transmission of energy and power.
- measure the efficiency.

4.1 Work

We use the term ‘work’ in various ways in our daily life. A gatekeeper guarding a house all day long, sitting on a tool, may claim to have done a lot of work, but in the words of physics that is not any work. In terms of physics the word ‘work’ is well defined. If a force F is applied on any object and the object traverses a distance s during the application of force (that is displacement occurs) then, the amount of work W done by the force is:

$$W = Fs$$

Unit of work: J (Joule)

Dimension of work $[W] = ML^2T^{-2}$

Force is a vector quantity and the distance traversed or the displacement is also a vector quantity but in case of work the product of those two vectors is a scalar quantity.

As individual vectors there is no such condition that the direction of force and distance travelled has to be same but in these book, we will only discuss the force and distance travelled in the same direction.

Have you noticed, while discussing work, we said that the ‘force’ has done the work. A person or a machine may push any object to some distance by applying a force. In terms of daily life we say that the person or the machine has done the work. But in physics, neither the person nor the machine does the work, always the force applied does the work. This force may be applied by a person or a machine.

Let us assume that, you have pushed an object to a distance s by applying a force F and left it after setting it in motion. The object has travelled an additional distance d and at last it has stopped. How much work is done?

The amount of work done is $W = Fs$, as no force was applied while traversing the distance d , so no work is done.



Example

Question: Your mass is 50 kg. You have climbed up a 10 storied building, how much work have you done? (Height of each floor is 3 m)

Answer: If your mass is 50 kg, your weight is $50 \times 9.8 = 490$ N. This weight is a force, that is acting downwards. If you want to climb up, you have to exert an equal force upwards to draw yourself up.

So, upward applied force: 490 N

Distance travelled upwards: 10×3 m = 30 m

So the amount of work done, 490 N \times 30 m = 14700 J = 14.7 kJ

Suppose, a moving object is coming towards you, you try to stop the object by applying force F , the object pushes you backwards by a distance s . How much work was done by the force applied by you? Certainly you have noticed that, this time the distance traversed is not along the direction of force, rather opposite to it. So the amount of work done

$$W = F(-s) = -Fs$$

That is, the work done is negative. In our daily lives, we talk about work and useless work, but what is meant by positive and negative work in terms of physics? If the work is positive, then it can be said that the work is done by the force. If it is negative, then it is said that the work is done 'on' the force or against the force. We must have a clear conception about energy before understanding what has just been written.

4.2 Energy

In our daily life we use the term "energy" for different purposes but in physics it has a definite meaning. Generally speaking, there is no difference between applying energy or applying force, but in physics, these two phrases mean completely different things. In the previous chapter, we have learnt what is meant by force, what is meant by energy will be discussed in this chapter.

We all have a shallow idea about energy, because we mention the words electrical energy, thermal energy when we make casual conversation. Sometimes we even hear about chemical energy or nuclear energy. Though light

is not mentioned as energy, we can assume that light is one kind energy too. The energy which is not mentioned in our daily conversation, but will be discussed a lot in physics is kinetic energy. We may think that there are many types of energy in nature, but it is interesting that all kinds of energy are the same and we can only transform them from one to another! So what is energy?

Ability to do work is energy! Not only that, when a positive work is done by applying a force on an object, the force creates an energy in that object. The amount of work done on the object is the amount of energy created in it, and the person who is applying the force has to give exactly the same amount of energy. So now you have understood the meaning of negative work. If any force does a negative work on an object, then it is to be understood that a certain amount of energy is taken away from the energy contained in the object. The amount of negative work done is equal to the amount of energy taken away, and he who has applied the force gets this energy anyway. So, on any object

Doing positive work → giving energy to the object.

Doing negative work → taking away energy from the object.

You can clearly understand that energy has no direction and it is a scalar quantity. As we produce energy by doing work or do work spending energy, these two have the same unit and the same dimension.

Unit of energy: J (Joule)

Dimension of energy $[W] = ML^2T^{-2}$



Example

Question: You have moved an object 10 m by applying a force of 100 N on it. If the frictional force is 10 N in the opposite direction, then what is the amount of work done by you? What is the amount of work done by the frictional force? (Figure 4.01)

Answer: You have done work,
 $W = Fs = 100 \text{ N} \times 10 \text{ m} = 1000 \text{ J} = 1 \text{ kJ}$.
 Work done by the frictional force,
 $W = Fs = -10 \text{ N} \times 10 \text{ m} = -100 \text{ J}$

The stone has attained energy because of the work done by you. Energy has been lost due to frictional force, so heat may also be generated.

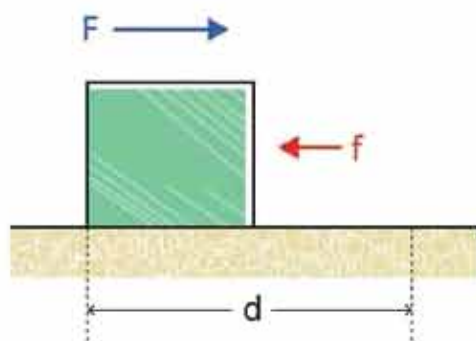

Figure 4.01: when a force is applied on a body, frictional force acts in the opposite direction.

4.3 Different forms of energy

We use different kinds of energy for different purposes. For example, heat energy is needed for water to be heated, we need light energy to see anything, we hear by using sound energy. We run machines by using electrical energy, and we create electricity from electric cells by using chemical energy. We generate electric energy too from the nuclear energy we get by dividing a heavy nucleus or by addition of light nucleuses. Energy is developed in our body taking nutrition from food, we perform our activities.

The history of our civilization itself is the history of utilization of energy by generating energy. We see different forms of such energy around us, for example-mechanical energy, heat energy, sound energy, light energy, magnetic energy, electrical energy, chemical energy, nuclear energy and solar energy.

The most general form of energy is the mechanical energy, the energy that is obtained due to position, shape and motion of the object is called mechanical energy. There are two forms of mechanical energy; these are kinetic energy and potential energy.

4.3.1 Kinetic Energy

We have discussed earlier that the ability to do work is energy. Everyone of us knows that when an object is in motion, it can push another object and set it into motion resulting in the object moving a certain distance due to the pushing. Making another object move means, definitely a force has been applied there and traversing a distance due to this force means work is done there!

Therefore we can say firmly that the energy that develops due to motion in a body is certainly one kind of energy or kinetic energy. In the previous chapter we said that the terrible road accidents that happen and the losses that occur are mainly due to kinetic energy. When a bus-truck or a car moves at high speed then it has a huge amount of kinetic energy.

We can easily calculate how much kinetic energy is produced by an object when work is done by a force on that object.

Let an object of mass m be displaced by an amount s due to the application of force F . Therefore work done W by the force F is:

$$W = Fs$$

According to Newton's second law we know,

$$F = ma$$

Again, from the equations of motion we know that if an object starts its motion from rest,

Then

$$s = \frac{1}{2}at^2 \text{ and } v = at$$

Then work, $W = Fs = mas = ma \times \frac{1}{2}at^2 = \frac{1}{2}ma^2t^2 = \frac{1}{2}mv^2$

Therefore we can say if a force F makes a displacement s of an object then the kinetic energy that is generated:

$$T = \frac{1}{2}mv^2$$

The velocity v is in the square form in kinetic energy, so to double the velocity of an object we will need to apply four times of the energy.

When learning the equations of motion, we noticed that

$$v^2 = u^2 + 2as$$

Multiplying both sides by $\frac{1}{2}m$ the equation becomes $\frac{1}{2}mv^2 = \frac{1}{2}mu^2 + mas$

If we write F instead of ma and W instead of Fs , then the equation becomes,

$$\frac{1}{2}mv^2 = \frac{1}{2}mu^2 + W$$

That is, if an object moves with velocity u , then its kinetic energy is $\frac{1}{2}mu^2$ and if W amount of work is done on it, then its kinetic energy is increased to $\frac{1}{2}mv^2$. When we were mentioning this equation ($v^2 = u^2 + 2as$) of motion we said that later we will see it in an interesting form. This is that form, i.e. the equation

of motion is nothing but the equation of kinetic energy.



Example

Question: A force of 10 N is applied on a stationary object of mass 10 kg for 10 s. (a) What is the kinetic energy of the object? (b) Calculate the kinetic energy after 20 s. (c) If the force is applied for 20 s, then what is the kinetic energy?

Answer: Acceleration due to 10 N force is:

$$a = \frac{F}{m} = \frac{10\text{N}}{10\text{kg}} = 1 \text{ m/s}^2$$

Therefore velocity after 10 second:

$$v = at = \frac{1 \text{ m}}{\text{s}^2} \times 10 \text{ s} = 10 \text{ m/s}$$

(a) Then the kinetic energy,

$$\frac{1}{2}mv^2 = \frac{1}{2} \times 10 \times 10^2 \text{ J} = 500 \text{ J}$$

(b) Acceleration will take place for 10 s, after that no acceleration is present, so velocity is unchanged, therefore kinetic energy after 20 s will be the same.

(c) If force is applied for 20 s, then the velocity is,

$$v = at = 1 \text{ m/s}^2 \times 20 \text{ s} = 20 \text{ m/s}$$

Therefore the kinetic energy,

$$\frac{1}{2}mv^2 = \frac{1}{2} \times 10 \times 20^2 \text{ J} = 2000 \text{ J}$$

Question: Motion is created in a body of mass 10 kg by applying a force, if its kinetic energy becomes 80 J, what is its velocity?

Answer: Kinetic energy is,

$$\frac{1}{2}mv^2 = 80 \text{ J}$$

$$v^2 = \frac{2 \times 80 \text{ J}}{m} = \frac{160 \text{ m}^2}{10 \text{ s}^2}$$

$$v = 4 \text{ m/s}$$

4.3.2 Potential Energy

When we were discussing work, we said that if a force does a positive work on an object then energy is generated. When we were talking about kinetic energy we gave the example of this too. We have shown that by applying a force on an object if the object moves by a distance, then its kinetic energy becomes $\frac{1}{2}mv^2$

Now, we will give such an example where force is applied and displacement occurs even when no kinetic energy is produced. Suppose, a spring is kept on a table as shown in figure 4.03. You applied a force at the free end of the spring by your finger and compressed it by an amount x . In such a condition, none of your hand or spring is in motion, so no kinetic energy is present in any of them. Since the direction of applied force and the distance traversed is in the same

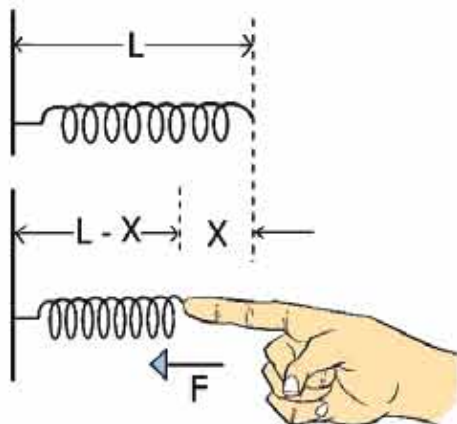

Figure 4.02: Stationary state of a spring and compressed by applied force

direction, so the work done is positive. According to the definition of work, here energy is to be created. But where is that energy? Here nothing is in motion, so definitely there is no kinetic energy.

Those of us who have used springs can guess that energy is definitely hidden in the compressed spring. Because if an object of mass m is kept before the compressed spring and then released, the spring would exert a force on it and make a displacement, which means the spring would perform work. That is it's a kind of energy, even it is not kinetic energy, this is another form of energy. This type of stored energy is called potential energy. This energy is developed due to the 'state or position' of the object.

If the constant of a spring is k , and if the spring is compressed by a distance x from its normal state, then the potential energy stored in it is,

$$V = \frac{1}{2}kx^2$$



Do Yourself

If a spring is compressed or expanded by an amount x , it will exert a force of $F = -kx$, using this equation it is possible to find out the relation, $V = \frac{1}{2}kx^2$. Can you find it? (Since the force depends on the length of the spring, so calculate the average force and multiply it by the total distance.)



Example

Question: A body of mass 10 kg falls on a spring with a velocity of 10 m/s. If the spring constant $k=100,000 \text{ J/m}^2$, what is the compression?

Answer: Kinetic energy of the object,

$$\frac{1}{2}mv^2 = \frac{1}{2} \times 10 \times 10^2 \text{ J} = 500 \text{ J}$$

This energy will compress the spring, that is,

$$\frac{1}{2}kx^2 = 500 \text{ J}$$

therefore,

$$x^2 = \frac{2 \times 500}{100,000} \text{ m}^2 = \frac{1}{100} \text{ m}^2$$

$$x = 0.1 \text{ m}$$

When we raise anything, then it acquires potential energy. When a piece of stone is released freely from above, its speed increases when it comes down. So it develops a kinetic energy. This becomes possible because a kind of potential energy was stored in it when it was in the 'above' position. How much potential

energy is stored in a stone when the stone is raised above can also be calculated. You are realizing that the amount of work to be done when an object is raised above is stored in that object as potential energy. If the work done is W ,

$$W = Fh$$

Here, F is the applied force and h is the height. We have to apply the force F in the upward direction and distance traversed is also in the upward direction, therefore F is positive. The force that has to be applied for raising the object upwards does not change as the spring force and this force is equal to the weight of the stone. If the weight of the stone is mg ,

$$F = mg$$

and

$$W = mgh$$

We have to remember that the weight of the stone is a force and it acts downwards. We have to apply an upward force equal to the weight of the stone if we want to lift it.

Potential energy is stored in a stone of mass m by raising it a distance of h . What amount of kinetic energy will be generated in the stone if it is released and comes down by a distance h ?

Due to the conservation of energy total of its potential energy will transform into kinetic energy. We know kinetic energy is $\frac{1}{2}mv^2$, so we can write:

$$\begin{aligned} \frac{1}{2}mv^2 &= mgh \\ v^2 &= 2gh \end{aligned}$$

Honestly we can say, when we were deducing the laws of falling bodies, we deduced this identical law once again! Now we deduced the same law using the conception of energy quite in a different way!



Example

Question: A body of mass 10 kg is thrown in the upward direction with a velocity of 100 m/s. What will be the height reached by the object?

Answer: This has been done before with the help of the laws of motion. Now it can be done by the transformation of energy.

$$\text{Kinetic energy:} \quad = \frac{1}{2}mv^2 = \frac{1}{2} \times 10 \times 100^2 \text{ J} = 50,000 \text{ J}$$

When the object reaches a height h , at this height the kinetic energy has been totally converted into potential energy. So,

$$mgh = 50,000 \text{ J}$$

$$h = \frac{50,000 \text{ J}}{mg} = \frac{50,000}{10 \times 9.8} \text{ m} = 510 \text{ m}$$

For your understanding the mass 10 kg is mentioned here. But it does not depend on the mass. With any mass we will get this answer. For this we might have used the formula $v^2=2gh$ directly.

Question: A body of mass 5 kg is thrown in the upward direction with a velocity of 50 m/s. At what height will the potential and kinetic energy be the same?

Answer: Initial kinetic energy of the body is

$$T_0 = \frac{1}{2}mv^2 = \frac{1}{2} \times 5 \times 50^2 \text{ J} = 6,250 \text{ J}$$

When kinetic energy equals potential energy, then for height h , we can say

kinetic energy = potential energy

kinetic energy + potential energy = primary kinetic energy

kinetic energy = potential energy = primary kinetic energy/2

$$mgh = \frac{6250 \text{ J}}{2}$$

$$h = \frac{6250 \text{ J}}{2 \times mg} = \frac{6250}{2 \times 5 \times 9.8} \text{ m} = 63.78 \text{ m}$$

You may have already guessed that this problem also does not depend on the mass.

4.4 Sources of energy

The history of world civilization can be simply named as the history of utilization of energy. It can be generally said, that a simple means to understand how developed a country is to calculate the use of electrical energy per person in that country. Different forms of energy of the world are shown in the figure 4.03.

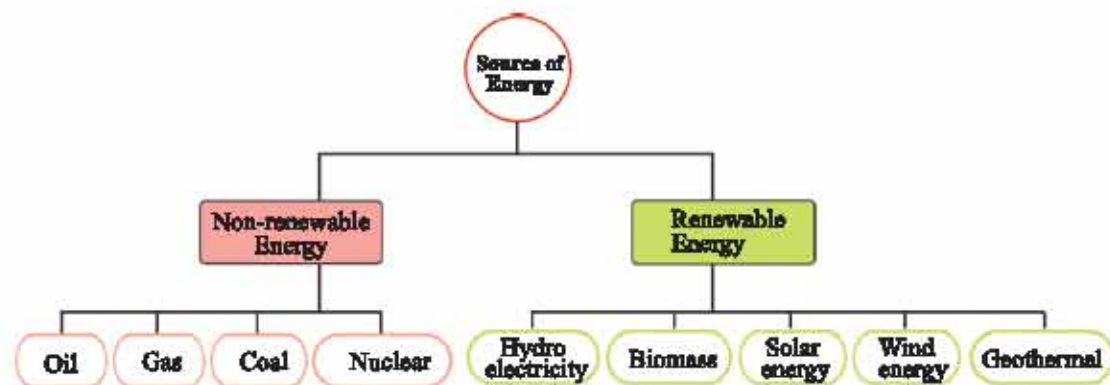

Figure 4.03: Different sources of energy

4.4.1 Non-renewable Energy

As the history of civilization on earth is actually the history of energy utilization, we see there is a hunger for energy in every country and every state in the world. Everyone is searching for energy and using it in every possible manner.

Fuel Energy (Oil, gas and coal): At this moment, the biggest sources of energy of the world are oil, gas or coal. Oil, gas or coal, are all fossil fuels, that is, being buried under the ground from millions of years, are transformed into this form due to prolonged period of heat and pressure. Coal, oil or gas are to be extracted from beneath the ground. The oil that is extracted from the ground (Crude oil) is very dense at the primary stage, which are converted into petrol, diesel, or kerosene by refining in refineries and some other usable substances are found as well. The gas that comes out from beneath the ground is mainly methane CH_4 , water vapors and other gases can be mixed with it and these are to be separated. The gas of our country Bangladesh is comparatively much clearer and suitable for direct use.

Nuclear Energy: Many countries are utilizing nuclear energy, and one type of fuel is also required there which is uranium. There is a similarity in the energies, oil, gas, coal or uranium; they are spent when they are used. Men have already estimated the amount of uranium in the world or the amount of oil, gas or coal beneath the ground. It is seen that if people continue to use energy at the rate they are doing now, the sources of energy like oil, gas, coal or uranium will be exhausted hundred years at best. After that our known sources of energy will run out. People are not that much concerned about what will happen then, because they are almost sure that by them some other sources will be found using science and technology. For example, nuclear fusion, using which the sun or stars produce their energy. The fuel for fusion comes from one isotope of hydrogen and each molecule of water contains two atoms of hydrogen. So, there is no worry for that to run out.

4.4.2 Renewable Energy

Human being are not only relying upon new forms of energy in the future, but at this very moment they are also dependent on the sources of energy, which will not be finished. This energy comes from sunlight, ebb and flow of the waves of seas, winds in open fields, hot magma from the interior of the earth or currents of water of rivers. It is not difficult to understand that these sources of energies are almost inexhaustible. These are called renewable energy- i.e. the energy which can be renewed, and because of that, there is nothing to be worried about. At present one fifth of the energy people are using world wide is this renewable energy. As days are going by, people are getting aware of the environment. And so the use of this type of energy is increasing more and more.

Hydroelectricity: One fifth of the total energy of the world is renewable energy. Most of that part is hydroelectricity, to produce electricity by making a dam in a river. Since the water of a river is inexhaustible, therefore the source of energy of such a power plant is inexhaustible. This is the conventional concept. But if a dam is built on a river, it harms the environment to a great extent; due to this the people of the world have become very conscious. Those who are a little bit farsighted don't build such a power plant more.

Biomass: After hydroelectricity, the most renewable energy comes from biomass, by biomass we mean wood fuel, straw etc. People in many parts of the world have no oil, gas or electricity; they spend their daily life by burning fuel wood and straw. The used energy by these poor people is a major part of the total energy of the world. Even the dried tree, straw etc. are finished due to burning,

biomass is called the source of renewable energy because the trees can be grown again. It is not lost for ever from the world like oil, gas or coal.

The important sources of energy are solar energy, wind energy, bio fuel and geothermal energy besides the two forms of renewable energy, hydroelectricity and biomass.

Solar energy: Many of you will be astonished on hearing that, only in one square kilometer area we get one thousand megawatt energy from the sun as light and heat which is close to the energy of a nuclear power plant. One part of the light and heat that comes from the sun is absorbed by the atmosphere. It is absent at night and uncontrolled due to cloud and rain. Beside this, the energy comes as light and heat energy, it has to pass one step for conversion into electricity. It is still said to be the most reliable source of energy. Utilizing solar heat electricity can be generated. Now-a-days a common picture of the earth is the solar panel, installing this on their roofs; people are generating their own electricity sitting in their own residence.

Wind energy: After solar energy, wind energy has occupied an important place very quickly. In our country we are not familiar seeing large turbines for wind energy, but in many countries of Europe this is a very familiar scene. The place at which the wind mill is set up, a large tower is erected upwards, so there is no waste of land at all, for this reason the environmentalists like it very much. From a wind turbine it is possible to get a few megawatts of electricity! The utility of the energy that is generated by using air; is increasing by 30% every year. This number is not a small number at all.

Bio fuel: The people of the world are preparing alcohol for drinking purposes from a long time- it is one kind of fuel. Preparation of alcohol as fuels from food like popcorn and sugarcane are almost an acceptable procedure. The oil that we use for cooking purposes can also be used instead of diesel. There are many kinds of trees in the world from which we can get fuel oil directly. In many countries of the world, the research on biofuel is continuing, moreover many countries like Brazil have started using such types of biofuel on a large scale.

Geothermal energy: Another important source of renewable energy is geothermal energy. The inner part of our earth is very hot, when a volcano's eruption takes place then we become aware of it. So, if someone can make a

hole a few kilometers deep, then he will get a giant source of heat energy. The process is still not easy so its large scale use has not yet started. In some places due to its geographical nature this type of energy is available easily and its use has started there.

4.4.3 Transformation of energy and impact on environment

People around the world are becoming conscious about the environment. For prosperity we need energy but the people of the modern world cannot tolerate it if the environment is destroyed for energy. The people of the world are not ready to use any type of energy by any means. They want to explore the energy that is hidden in the world not by making conflicts with nature and not by destroying the earth.

The largest example of the impact of transformation of energy on nature is the fossil fuel or oil, gas and coal. Among these three, the amount of carbon is much more and when these are burnt to produce heat energy then carbon dioxide gas is produced, which is a green house gas. Therefore, this gas can confine the heat of the world and due to this the temperature of the world is increasing slowly, which is called global warming. Due to global warming the ice of the polar region is melting and the height of the sea level is rising. Bangladesh is one of the countries of the world which will be flooded and the farmlands destroyed by salt water thus creating a harmful impact on nature. At present, all the countries of the world are unitedly trying to decrease the amount of carbon dioxide emission.

There is no emission of carbon dioxide in a nuclear power plant. But nuclear wastage is highly radioactive and these have to be preserved for millions of years for their radioactivity to reach a safe level which is not hazardous for the environment. Though nuclear power plant is very safe due to modern technology, sometimes owing to people's mistakes or natural calamities major accident happens to creates a fatal disaster. Two examples of this type are accidents of Chernobyl of the then Soviet Union and Fukushima of Japan. Comparatively the impact of renewable energy on the environment is less. But when a dam is made on a river for production of hydroelectricity, then on one hand the environment is damaged due to flooding in a large region, whereas on the other hand, due to less flow of water draught may be created in the subsequent regions.

4.5 Conservation and Transformation of Energy

4.5.1 Conservation of energy

In our daily life, the energy we see around us is imperishable. It has no destruction, it transforms only from one form to another form. When a stone is raised, it develops a potential energy. When the stone is released, the potential energy starts decreasing and the kinetic energy starts increasing. Just before it touches the ground, its total energy is converted into kinetic energy. But when the stone stops after touching the ground, then it contains no kinetic energy and no potential energy, where has the energy gone?

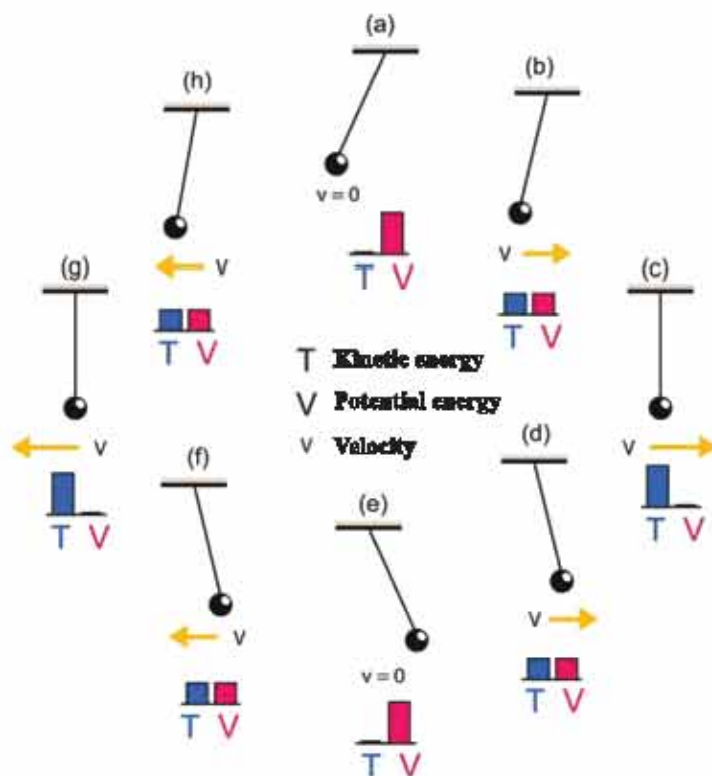

Figure 4.04: A pendulum is oscillating, the total energy is exchanging between kinetic energy and potential energy.

You definitely have observed that when a stone hits the ground, it hits by producing sound and heat i.e. kinetic energy is transformed into sound or heat energy.

The example (Figure 4.04) of changing between potential and kinetic energy is wonderful. A small stone is tied by a thread and hanged from a support. If we pull it along one side then the stone goes up by a small amount from its stationary position and hence a potential energy is developed in it. Now if we release the stone, due to an unbalanced force on it, it starts going towards its stationary state, thus creating a motion in it. When it reaches the mid position exactly, it attains the maximum velocity. So it does not stop there rather moves away in the opposite direction and rises up until its velocity becomes zero. Therefore, it again develops a potential energy. When it reaches the maximum height it stops there, owing to its potential energy again it starts moving towards the stationary state. In this way, the stone oscillates and transformation from potential energy to kinetic energy and kinetic energy to potential energy continues. This process would continue for an infinite time if there was no friction and other causes of energy loss.

Therefore, the transformation of energy is a very natural process. Transformation of energy takes place not only between potential energy and kinetic energy. But all the known forms of energies around us can transform from one form to another. In our daily lives, the energy we see around us cannot be created or even can be destroyed, it only changes from one form to another. This is the law of conservation of energy.

4.5.2 Transformation of Energy

Around us we see many examples of transformation of energy, e.g.

(a) Electrical energy

If we want to give example of the transformation of energy, at first we give examples of electrical energy. Because this energy can be transformed into other energy very easily. Not only this, it is easiest to transmit electrical energy from one place to another. Though around us there are many types of energy, we supply electrical energy first to our residence but we don't supply other forms of energy. In our daily lives, we see the transformation of electrical energy into mechanical energy in electric fans or other motors. (Though actually magnetic energy is not different from electrical energy, even then in motor or electrical fan we see electrical energy converts first into magnetic energy and then converts into mechanical energy.) In the electric iron or heater it is

converted into heat energy. The electrical energy is converted into light energy in light bulbs, tube light or in an LED. To produce sound energy we need to vibrate something. It's a kind of mechanical energy. Moreover we can tell, in speakers, electrical energy is converted into sound energy. All of us charge the battery of our mobile using electricity, where the electrical energy is converted into chemical energy.

(b) Chemical energy

Chemical energy is certainly an important example of transformation of energy. The gas which is used for cooking is an example of transformation of chemical energy into heat energy. Due to this, when electrical energy is supplied to our residence, simultaneously gas is also supplied. Due to the conversion of chemical energy into heat energy, we also get light energy.

The light of a candle is an example. We see the transformation of chemical energy into mechanical energy using gas, petrol, diesel or such type of fuels in different kinds of engines. If we observe closely, we will find that at first chemical energy is converted into heat energy and then heat energy is converted into mechanical energy. But in the era of modern technology, the greatest example of conversion of chemical energy is the battery, where chemical energy is converted into electrical energy. We cannot find any space where chemical energy is not converted into electrical energy using battery starting from mobile phone to car or from clock to space shuttle. The amazing example of chemical energy is our body or body of living beings, where chemical energy from food is converted into mechanical or electrical energy.

(c) Heat energy

If we consider from the viewpoint of quantity, the conversion of maximum amount of energy undoubtedly takes place from the heat energy in the world. Heat energy is transformed into mechanical energy in all engines of all machines. In thermocouple (applying heat at the junction of two different metals), though there are examples of conversion of heat into electrical energy directly, actually almost in all the cases heat energy is converted into mechanical energy and then mechanical energy is converted into electrical energy. (To save the environment we don't like the dissipation of energy now-a-days, so we use energy saving bulbs more instead of using light bulbs where light is produced due to heating.) We see the transformation of heat energy into light energy from heated gas particles of flame of a candle where heat is generated from chemical energy or from the filament of a bulb.

(d) Mechanical Energy

When electrical energy is produced by a generator, actually electrical energy is produced by rotating a coil of wire in a magnetic field by utilizing the mechanical energy. Heat energy is always being produced due to friction, there mechanical energy is transforming into heat energy.

(e) **Light Energy:** Light is an electromagnetic wave and we can see a definite range of the wavelengths of this wave, we call this light. Waves of wavelength more or less than this range is present in nature and we have generated those in different ways. For example, in a microwave oven, we convert the electromagnetic wave into heat energy. Now-a-days using solar cell light is transformed directly into electricity. Now-a-days the uses of photographic plate is decreasing day by day, but all of us know that the presence of light in a photo sensitive photographic film generates chemical energy.

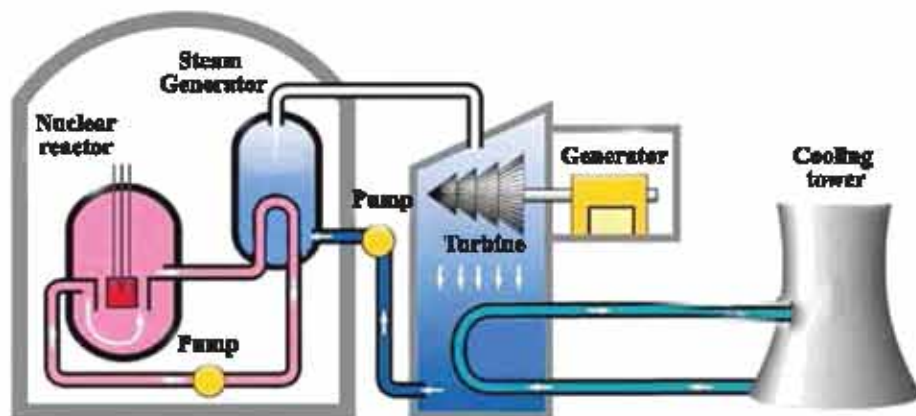

Figure 4.05: Structure of a nuclear power center

(f) **Mass:** You are definitely surprised seeing the word 'mass' suddenly in different types of transformation of energy. When we mean energy, then we never imagine the mass as energy directly. But Einstein showed using his laws of relativity, $E = mc^2$ and with the help of this equation he informed us about the possibility of transformation of mass into energy. In the nuclear bomb, the mass was transformed into energy, where a huge amount of heat, light, and sound energy destroyed the cities of Hiroshima and Nagasaki. This process of energy transformation can be used not only in nuclear bombs but also in nuclear power

station. Though heat is produced here directly, using this heat energy steam is produced and this steam is used to rotate the turbine, then this rotating turbine generates electricity in a generator(Fig: 4.05).

We have to know an important matter though such types of transformation are taking place around us. Although there is available energy, but this energy cannot always be used. In the oceans of the earth, there is a huge amount of energy, but we cannot use this energy. (Sometimes using this energy cyclones destroy cities, habitations!) When energy is transformed from one form to another form, then a part of it is dissipated. Actually this dissipation occurs in the form of heat energy and this cannot be regained for further use. This dissipation of energy actually is not the limitation of technology. It is a rule restricted by physics.

At the very beginning of learning science many don't know it and they try to make an everlasting machine for transformation of energy from one form to another form. (A motor is rotating the generator and producing electricity, again using this electricity the motor is rotating. This is an example of perpetual machine. It will never work).

4.6 Relation between mass and energy

You know, in the theory of relativity by Einstein it is said that the mass of an object and the energy are identical things. If the mass m is transformed into energy, then this energy is E , and its amount is $E = mc^2$, here c is the light velocity. The velocity of light (3×10^8 m/s) is huge, if it is squared it becomes huge also, it means if we can transform a little mass into energy, we will get a huge amount of energy, in a nuclear power plant just this thing is done.

In a nuclear power plant, one of the fuels that are used is uranium 235. Here there are 92 protons and 143 neutrons. Its amount in nature is very small, only 0.7%, its half life is 703,800,000 (704 million) years. A uranium 235 nucleus can capture another neutron very easily (if the speed of that neutron is small). Then the uranium 235 nucleus becomes very unstable, then it is divided into two small nuclei Kr^{92} and Ba^{141} . In addition to this, three more neutrons come out (Figure 4.06), which is depicted in the equation below. If anyone finds out the mass that remains in the left side of the equation and compares it with the mass that remains on the right side, will see that on the right side mass is less, the less amount actually emerges out as energy governed by the equation, $E = mc^2$.



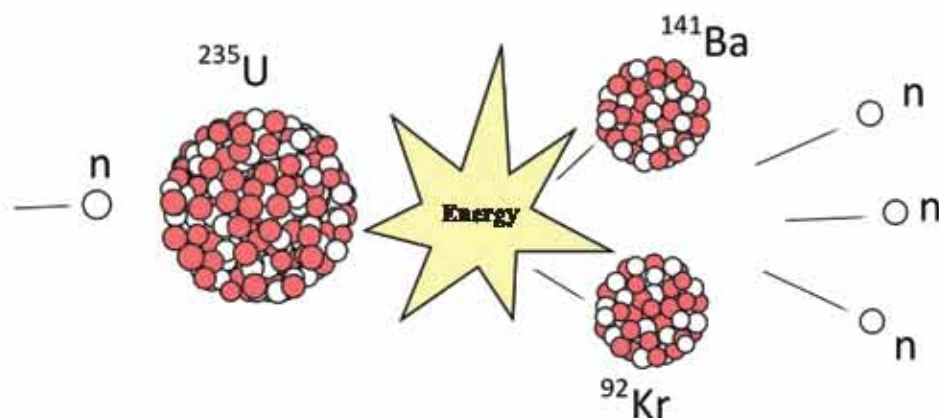

Figure 4.06: Energy production from nuclear reaction

In this reaction, the three neutrons that have come out, actually come out with huge speed, so the other uranium (^{235}U) nuclei cannot capture them very easily. If by some means their kinetic energy can be lowered, then they will be captured by other uranium (^{235}U) nuclei and thus will break it creating some more energy and releasing three new neutrons. In a nuclear power plant, this work is done, so when the speed of the emerging neutrons goes down, they again break other nucleuses and this process continues. This process is called a chain reaction.

In this process, a huge amount of heat energy is produced, using this heat energy water is vaporized and turbine is rotated with the help of this vapor and electricity is produced from the generator. This type of power plant is called a nuclear power plant. It is possible to get thousands of megawatt power from such a power plant very easily. The wastage material that is produced after the nuclear reaction is terribly radioactive; so many types of precautionary measures have to be taken when processing them. If the excess neutrons that emerge after a nuclear reaction are absorbed somewhere else by any means, then the nuclear reaction ceases. There is a special type of rod called a control rod to absorb the neutrons in a nuclear reactor. These are used to control the nuclear reactor.

4.7 Power

The term 'power' is used a lot of times in our daily lives, and it is not that the term is always used in a positive sense! But the word 'power' has a definite meaning in physics; power is the rate of doing work. That is, if work W is done in time t , then power P is:

$$P = \frac{W}{t}$$

We have seen before that work is nothing but transformation of energy. As energy can't be destroyed, so it is only being transformed by doing work. So we can say, if we desire, power is the rate of transformation of energy. As work or energy is a scalar quantity, then power is also a scalar quantity.

We have known about different quantities, their units, and tried to know their dimensions in every case while learning physics. Unit and dimension of power are:

Unit of power: W (Watt)
Dimension of power: $[P] = ML^2T^{-3}$

Though we have known it here for the first time, it's unit is very familiar to us. If 1 Joule work is done per second then we say, work done is 1 watt or transformation of energy takes place. If we switch on a light bulb of 100 watt that means, in this bulb 100 J energy is being spent in each second. When we read in the newspaper that a 1000 MW nuclear power plant will be built in our country that means in that power plant, 1000×10^6 J electrical energy will be produced in each second.

4.8 Efficiency

We have said earlier that a certain amount of energy is wasted every time while transforming energy from one form to another. So we have to give a little more energy than the amount of work we want to do. We use various types of machines and engines in our day to day lives. It is seen always that energy is wasted due to friction or some other causes. That is why almost always we need to measure how efficiently a machine or engine is using energy. So, we use a

new quantity called efficiency. Efficiency can be expressed in percentage as:

$$\text{Efficiency} = \frac{\text{amount of work}}{\text{energy given}} \times 100 = \frac{\text{amount of work} - \text{energy wasted}}{\text{energy given}} \times 100$$



Example

Question: If an object of mass 10 kg is lifted 10 min 15 s using a motor of 1000 W, then what is the amount of wasted energy? What is its efficiency?

Answer:

$$\text{Amount of work: } 10 \times 9.8 \times 10 \text{ J} = 9,800 \text{ J}$$

$$\text{Energy given: } 1000 \times 15 \text{ J} = 15,000 \text{ J}$$

$$\text{Energy wasted: } 15,000 - 9,800 = 5,200 \text{ J}$$

$$\text{Efficiency} = \frac{9800 \text{ J}}{15,000 \text{ J}} \times 100\% = 65.3 \%$$

You will be surprised to know that, energy is wasted in every step of production of electricity in a power plant, and if all these wastage is taken into account, the efficiency of the power plant can drop down to 30%.

Question: If 10% energy is wasted in every step, what is the efficiency in 4 steps?

Answer: $0.9 \times 0.9 \times 0.9 \times 0.9 = 0.6561$
Or 65.6%



Investigation 4.01

Physical ability

Objective: To find out the physical ability of a student

Instruments: A clock and a ruler

Procedure:

1. A building which has stairs to the first or second floor.
2. Count the number of steps of the stairs and measure the height of each step. Multiply these two to find out the height of the first or second floor from the ground.
3. Measure your mass on a weight measuring machine.
4. Climb the stairs as fast as you can, measure the time needed using a clock.
5. In a similar way, measure mass of the other students in the class and collect information about the time needed for them to climb the stairs. Put the data in the following table.
6. Find out the physical ability of your friends and yourself.

Height of the roof: $h = \dots\dots\dots$

Acceleration due to gravity: $g = 9.8 \text{ m/s}^2$

Name of the student	Mass (m) kg	Time required to reach the roof (t) s	Power = $\frac{mgh}{t}$ W	Average power

Find out the mean physical ability of all the students and see whether your physical ability is more or less than that.

4.9 Role of Energy in Development Activities

There is a very close relationship between development of a country and the use of energy. To speak the truth, the use of energy may be considered as the first parameter to see how developed a country is.

We should pay our first attention to education for the development of our country. A lot of students in our country are studying in schools, colleges and universities. We have to ensure an adequate supply of electricity to run these institutions properly. They need light for studying at night and their studies are hampered if the electricity supply is not ensured. Laboratories are to be used and computers and networks are to be kept active for higher education, and which has no alternative other than the supply of electricity.

Agriculture plays an important role in the economy of our country. As the country is small, amount of suitable agricultural land is less, and it is further decreasing. Our country has achieved self sufficiency in food by growing two or more crops in this agricultural land. For this reason, arrangements for irrigation are to be made in the agricultural land without waiting for the natural agriculture alone. Without energy supply this is not possible at all. Electricity or fuel is required to run the pumps for irrigation. Fertilizers are needed for agriculture and the necessary production is not possible without electricity and gas supply in fertilizer factories. Tractors are used to cultivate lands and for processing of crops, supply of fuel needed has to be ensured for tractors.

After agriculture, energy supply is needed to ensure health services. A healthy environment is needed for a sound body. In a densely populated area like Bangladesh, energy is required for creating a healthy environment and processing wastage. Energy is needed for pure water supply. Electricity supply can not stop for a single moment for health services in hospitals.

Other than education, agriculture and health services, energy is a must for the communication system, industries, mills and factories and creating the infrastructure of a country. That's why power plants are to be built through proper planning in our country to prevent shortage of energy in the future. Misuse of energy is to be stopped and search for gas continued in new gas fields. As the requirement of energy supply has increased quite a lot in the country, establishment of a nuclear power plant may be considered as a possible solution.



Exercise



General Questions

1. Why is the work done by frictional force is always negative?
2. If a spring is cut into two pieces will the spring constant k of the pieces increase or decrease?
3. To keep the earth dynamic which one is necessary? Energy or power?
4. Can mass be considered as energy?
5. If velocity is increased by 1%, what will be the percentage increase of kinetic energy?
6. A match stick is rubbed with its box with a force of 5 N. The stick is dragged 5 cm.
 - (a) What is the energy used in rubbing?
 - (b) What is the power needed if it takes 0.5s to drag the stick
7. The reservoir of a hydro-electric project is 800 m high from the sea level and the power station is 250 m high. The water of a reservoir rotates a turbine coming through the pipe. There is 20×10^8 liter water in the reservoir. If the mass of 1 liter water is 1 kg, find the potential energy stored in the water of the reservoir.
8. A boy of 40 kg can reach the roof top using the stairs in 12 s. The number of steps of the stairs is 20 and the height of each step is 20 cm.
 - (a) What is the weight of the boy?
 - (b) What is the height reached by the boy?
 - (c) What is the work done to reach the roof top?
 - (d) What is the power he uses to reach the roof?
9. It is more advantageous to produce nuclear energy than the power station that uses fuel because no green house gas is produced.
 - (a) What are the other advantages of using nuclear energy?
 - (b) What are the disadvantages of using nuclear energy?



Mathematical questions

1. Change of velocity of an object occurs due to the application of different forces at different times and this is shown in figure 4.07. Among OA, AB, BC and CD, when has positive, negative or zero work been done?

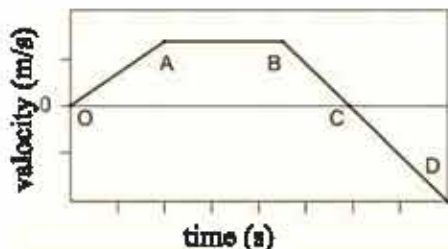

Figure 4.07: Graph of velocity-time

2. A girl of mass 50 kg has gone up the stairs at a height of 5 m in 10 s. how much work has she done? What is her power in horse power?

3. When a force was applied on a stationary object of mass 5 kg for 10 s, its kinetic energy became 500 J. Find the amount of force applied.

4. Two objects of masses 10 kg and 5 kg are attached to the two sides of a pulley and is kept stationary 5 m above the ground. If you release the two objects, then the 10 kg mass starts to come down and the 5 kg starts to go up. When the mass 10 kg has come down by 1 m and the mass 5 kg has gone up by 1 m, what are the velocities of the two masses?

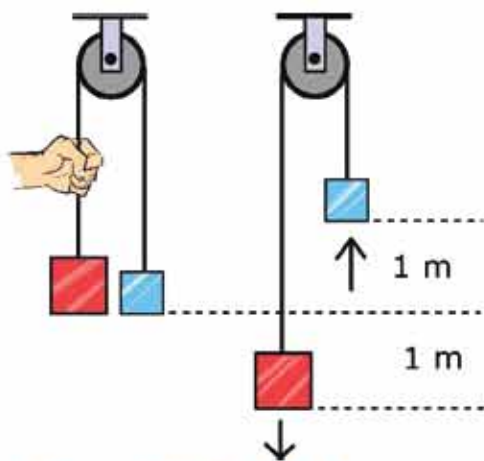

Figure 4.08: Two different masses attached to a pulley

5. If a body of 5 kg is released from a height of 100 m, at what height will the kinetic energy be twice of the potential energy?

save energy.

Which one is correct?

- a) i b) ii c) ii and iii d) i, ii and iii

6. What type of energy is stored when a body is stretched?

- (a) Kinetic energy (b) Potential Energy
(c) Heat Energy (d) Chemical Energy



Creative questions

1. A boy of mass 40 kg and a young man of mass 60 kg start running from the ground floor and reach the roof top at the same time. Both of them ran with the same velocity of 30 m/min.
 - (a) What is power?
 - (b) What do you mean by the work 50J?
 - (c) Find the kinetic energy of the young man.
 - (d) Explain with mathematical logic whether the power of both are equal or not.
2. Jeny resides in the 5th floor of a building. The height of each stair is 20 cm. There are 22 stairs in each floor and Jeny needs 4 minutes time to reach the 5th floor. Susmita requires 4.5 minutes to reach that 5th floor. It is to be mentioned that mass of Jeny and Susmita are 64 kg and 75 kg respectively.
 - (a) What is the main source of energy?
 - (b) Write two similarities between work and energy.
 - (c) Calculate the amount of work done by Jeny.
 - (d) Between Jeny and Susmita who has more power? Give reasons in favor of your answer.

Chapter Five

State of Matter and Pressure



Everest winner Nishat Mojumder is breathing using oxygen cylinder at the peak of Mt. Everest

We are familiar with three states of matter- solids, liquids and gases. Among them liquids and gases can flow so they are also called fluids. In this chapter we will analyse and see how matter exerts pressure in its three states. Not only that, elasticity is a special property of matter. We will also discuss how the property of elasticity works in the solid, liquid and gaseous state.

Besides solid, liquid and gas, there is another state of matter named plasma, we will also try to understand why this state is called the fourth state of matter.



By the end of this chapter we will be able to-

- explain the change of pressure with the change of force and area.
- determine the expression for pressure at a point in a liquid at rest
- explain the upward pressure on submerged bodies in a liquid
- explain Pascal's law.
- demonstrate practical application of Pascal's law
- explain the theory of Archimedes.
- explain the density.
- explain the usage of density in our everyday lives.
- explain why objects float on water.
- analyse the causes of accidents in the waterways of Bangladesh.
- explain the atmospheric pressure.
- determine atmospheric pressure by using the height of the liquid column.
- analyse the change of atmospheric pressure with the increase of height.
- analyse the effect of change of atmospheric pressure on weather.
- explain stress and strain.
- explain Hooke's law.
- explain the molecular kinetic theory of matter.
- explain the plasma state of matter.

5.1 Pressure

Though we use the word 'pressure' in our everyday conversation in many ways, the word has a definite meaning in physics. We have talked about applying many kinds of forces at different times in the previous chapters. But how the force will be applied was untold. For example you can push a stone with your one hand, two hands or with your whole body (Fig. 5.01). Though you apply the same amount of force every time, the pressure will be different. In the first case you applied force through the area of your palm. If your applied force is F , area of your palm is A then the pressure

$$P = \frac{F}{A}$$

Unit of pressure: $\frac{N}{m^2}$ or Pa (Pascal)

Dimension of pressure $[P] = ML^{-1}T^{-2}$

Therefore, in the second case because of using two hands, the pressure will be half as the area through which the force is being applied is doubled. In the third case, you applied force through your whole body, so the area through which force is applied will increase more and pressure will be decreased more.

Force is a vector, so you may think that pressure P is a vector! But the interesting matter is pressure P is a scalar quantity and if we want to write it perfectly then it should be written like as:

$$F = PA$$

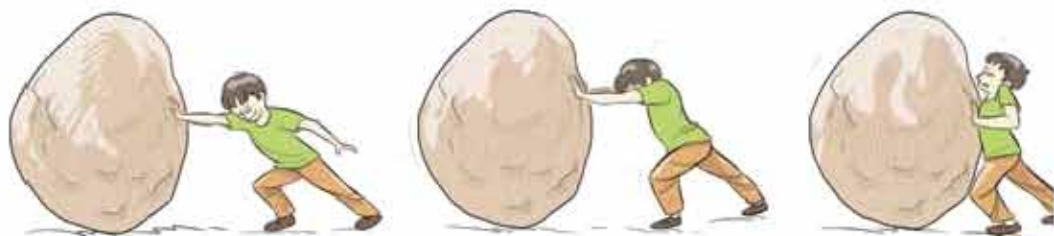

Figure 5.01: Pressure depends on the area through which force is applied

Therefore, area itself is considered as a vector! A vector must have a magnitude and the direction. The amount of area is the magnitude of vector, the perpendicular on the area is the direction of the vector.

Since pressure is a scalar quantity, it has no direction. It is so necessary, because the concept of pressure is more important for a liquid and gas than the solid. When liquids and gases apply pressure then actually it does not depend on the direction. We will see this matter very soon.



Example

Question: Let us assume your mass is 50 kg, area of one side of your body is 0.5 m^2 and bottom area of your two legs is 0.03 m^2 . What pressures will you apply on the floor when lying down and standing ?

Answer: Mass is 50 kg, therefore weight is: $50 \times 9.8 \text{ N} = 490 \text{ N}$

$$\text{Pressure when lying down, } P = \frac{490 \text{ N}}{0.5 \text{ m}^2} = 980 \frac{\text{N}}{\text{m}^2}$$

$$\text{Pressure when standing, } P = \frac{490 \text{ N}}{0.03 \text{ m}^2} = 16,333 \frac{\text{N}}{\text{m}^2}$$

You see less pressure is applied when you are lying down. For this reason when one falls in quicksand he has to lie down so that the applied pressure becomes lower and he does not submerge quicksand.

Again the opposite is also true, if the area of force applied is less, then the pressure increases. The area of the sharp edge of a nail is very small. So when the sharp point of the nail is placed on a wood or wall and hammered on the flat back head of the nail, the force exerts pressure through the sharp point on the wood or wall. As the area of sharp edge of the nail is just a point so pressure is very high and the nail can easily penetrate the wood or wall. This is also true in the case of a knife. Its sharp edge is narrow, so it can apply more pressure and

it is possible to cut easily. Another name of the unit of pressure is Pascal (Pa), when 1 N force is applied on an area of 1 m^2 we get 1 Pa (1 Pascal) pressure.

5.2 Density

We need to have a clear idea about density before understanding pressure of liquids and gases. Density is the amount of mass per unit volume, i.e. if mass of a body is m and volume is V , then density is:

$$\rho = \frac{m}{V}$$

Unit of density: kg/m^3 or gm/cc

Dimension of density: $[P] = ML^{-3}$

Density of some familiar substances is given in table 5.01. Here is a good thing to remember, if temperature increases or decreases, volume of a substance can be increased or decreased. Since there is no change in the mass, the density of substance may change with temperature. For this when we talk about density of a substance, usually we need to mention the temperature at which the density is measured.

Table 5.01: Density of some substances

substances	density (gm/cc)
Air	0.00127
Cork	0.25
Wood	0.4 - 0.5
Human body	0.995
Water	1.00
Glass	2.60
Iron	7.80
Mercury	13.6
Gold	19.30



Example

Question: 0.25 kg salt is dissolved in 1 kg water, so that the total volume becomes 1200 cc. What is the density of this water?

Answer: 1 cc is 1 cm^3 , therefore

$$1 \text{ cc} = (10^{-2} \text{ m})^3 = 10^{-6} \text{ m}^3$$

Density of the salted water: $\rho = \frac{1 \text{ kg} + 0.25 \text{ kg}}{1200 \times 10^{-6} \text{ m}^3} = 1.04 \times 10^3 \text{ kg/m}^3$

Question: Density of Dead Sea water of Jordan is 1.24 kg/liter. What is the volume of 1 kg water?

Answer: 1 liter is 1000 cc or 10^{-3} m^3 ,

Therefore, density of Dead sea water,

$$\rho = 1.24 \frac{\text{kg}}{\text{liter}} = \frac{1.24 \text{ kg}}{10^{-3} \text{ m}^3} = 1.24 \times 10^3 \text{ kg m}^{-3}$$

Therefore, volume of 1 kg water:

$$V = \frac{m}{\rho} = \frac{1 \text{ kg}}{1.24 \times 10^3 \text{ kg m}^{-3}} = 0.81 \times 10^{-3} \text{ m}^3$$

or 0.81 liter

Example: What is the density of the nucleus? What is the mass of 1 tea spoonful of nucleus?

Nucleus consists of neutrons and protons. The mass of one of them is $1.67 \times 10^{-27} \text{ kg}$, Their approximate radius is $1.25 \text{ fm} = 1.25 \times 10^{-15} \text{ m}$. Therefore, if we can calculate the density of neutron or proton, it can be considered as the density of the nucleus!

$$\text{Density of nucleus, } \rho = \frac{m}{\frac{4\pi}{3} r^3} = \frac{1.67 \times 10^{-27} \text{ kg}}{\frac{4\pi}{3} (1.25 \times 10^{-15} \text{ m})^3} = 0.204 \times 10^{18} \text{ kg/m}^3$$

You need to guess how big this number is! One tea spoon contains approximately 1 cc materials.

Therefore, mass of 1 tea spoon nucleus is:

$$m = 0.204 \times 10^{18} \text{ kg/m}^3 \times 10^{-6} \text{ m}^3 = 2 \times 10^{11} \text{ kg}$$

It is roughly the collective mass of all the people of the world.

We can see it in another way. An atom has neutron-proton in its nucleus, electrons remain outside. Mass of an electron is 1800 times less than the mass of neutron-proton. Therefore mass of an atom is really the mass of its nucleus. It does not matter too much electrons are not considered. But the things we see around us, their shapes are not the volume of the nucleuses. Volume of the substances come from the volume of their atoms. Electrons revolve around the very tiny nucleus comparatively in a bigger orbit. Radius of an atom is nearly 1,00,000 times bigger than that of a nucleus.

Therefore, we can say in another way, if we can gather all the people of this world and can create pressure to extract all nucleuses by breaking the atoms present in their body and then if we put them together, these will be confined in a tea spoon.

5.2.1 Uses of Density in our Daily life

Density plays a vital role in our daily life. Sometimes we do not notice it separately. For example, when we take water in a pot and hit it, after a while the water starts to boil. It happens because when the water in the lower portion of the pot becomes heated and expands, then its density decreases. As the density becomes less, that water goes up and the cold water in the neighborhood comes down. After some time this water also becomes heated and goes up and so within a short period of time the water starts to boil. (The process of heating gas or liquid in this way is called convection.) If density of water was not reduced after heating, then it would not go up and we could only heat the water in the lower part of the pot, by fire of the stove, and it would not be possible to heat the whole water of the pot.

In intense sunshine in summer, those who have jumped into a pond have surely noticed that though the surface water is hot but the bottom water is cold. Here the heat comes from above and after heating, the top water density decreases and remains above, the whole water of the pond can not be heated uniformly.

We have seen the balloons flying at the inauguration of various events. In order to make balloons fly we need to insert gases lighter than air. Considering safety they should be filled with inert helium gas, but helium gas is comparatively expensive; so frequently it is done with hydrogen gas which is very dangerous. Not only that, as methane gas is lighter than air, which is used as a fuel is

sometimes used also to fill the balloons, which is similarly dangerous!

We have often seen air balloons. Fires are lit under the balloons, which heat the air inside and make it lighter and this helps lift the balloon up.

We can determine whether the eggs are good or rotten by submerging them in water. If the eggs have gone bad their density becomes lower than that of water and they start to float.

5.3 Pressure in liquids

Those who have jumped in water, they all know, after going into deep water a pressure is felt. (Though atmosphere applies a pressure on us but we don't feel it, because our body also applies the same pressure.) Exactly what amount of pressure will be felt after going in deep water or any other fluid is already been mentioned. The pressure on you will have to be calculated from the weight of the column of liquid on you. Let us suppose that you want to determine the pressure of the liquid at depth h . Imagine an area A there (Figure 5.02). The weight of the column of liquid above this area will exert a force on A .

Volume of the liquid over a surface area A is Ah . If the density of the liquid is ρ then weight of this liquid or force is,

$$F = mg = (Ah\rho)g$$

Therefore pressure,

$$P = \frac{F}{A} = \frac{Ah\rho g}{A} = h\rho g$$

Therefore, in a liquid of fixed density, pressure rises with the increase of depth. In case of water, approximately for a ten meter increase in depth, the pressure increases by an amount equal to the air pressure (atmospheric pressure).

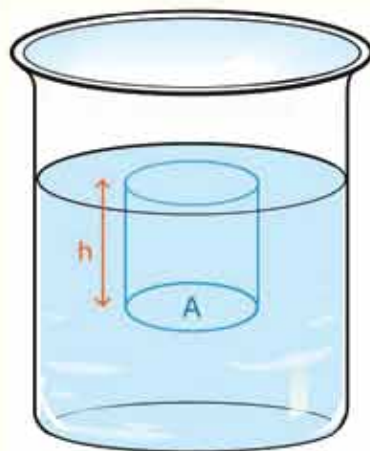

Figure 5.02: Pressure is created on the lower surface due to the height of the liquid.

Density can be increased by compressing air or gas by increasing pressure but same is not true for liquids (neither for solids !). Liquids cannot be compressed in the same way with pressure, so its density cannot be increased or decreased. How pressure of water is increases when we go from the surface to the bottom of a sea is shown in figure 5.03. Since the density of water is nearly uniform, the pressure is increasing at the same rate. Starting from zero at the surface of the sea, it is increased a lot at the bottom of the sea.

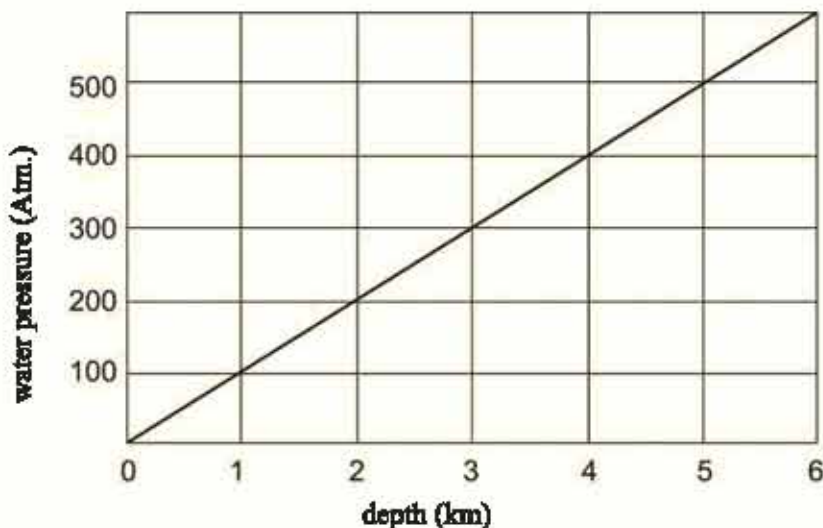

Figure 5.03: Pressure increases with the increase of depth



Example

Question: The whale can go into a depth of 2,100 m from the sea level. How much pressure can it sustain?

Answer: The whale can sustain the pressure,

$$P = \frac{2,100 \text{ m}}{10 \text{ m/atm}} = 210 \text{ atm}$$

Question: Under water, pressure increases by 1 atm for a 33 ft (10 m) increase of depth. The divers have gone a maximum depth of 1000 ft (330 m), how much pressure did they have to tolerate?

Answer: Per 10 m depth, pressure increases by 1 atm or 1 bar. Then, for 330 m depth,

$$\frac{330 \text{ m}}{10 \text{ m/atm}} = 33 \text{ atm}$$

Divers had to tolerate 33 atm pressure.

Question: Calculate the pressure at a depth of 50 cm for kerosene (density 800 kg m^{-3}), water (density 1000 kg m^{-3}) and mercury (density 13600 kg m^{-3}).

Answer: For kerosene,

pressure, $p = h\rho g$

$$P = 0.50 \text{ m} \times 800 \text{ kg m}^{-3} \times 9.8 \text{ N kg}^{-1} = 3,920 \text{ N m}^{-2}$$

For water,

$$P = 0.50 \text{ m} \times 1000 \text{ kg m}^{-3} \times 9.8 \text{ N kg}^{-1} = 4,900 \text{ N m}^{-2}$$

For mercury,

$$P = 0.50 \text{ m} \times 13,600 \text{ kg m}^{-3} \times 9.8 \text{ N kg}^{-1} = 666,400 \text{ N m}^{-2}$$

Question: At what depth of the liquids kerosene, water and mercury pressure will be 1 atm ?

Answer: We know, for mercury pressure is 1 atm at a depth of 76 cm. Density of water is 13.6 times less than mercury, therefore depth of water will be 13.6 times more.

Therefore, depth for water: $76 \text{ cm} \times 13.6 = 1034 \text{ cm} = 10.34 \text{ m}$

Density of kerosene is 0.8 times less than water, therefore depth for kerosene will be $1/0.8 = 1.25$ times more.

Therefore, depth for kerosene: $10.34 \text{ m} \times 1.25 = 12.92 \text{ m}$

5.3.1 Archimedes Law and Buoyancy

It is sure all of you know Archimedes Law and the story behind this law. The law is easy, 'If a body is immersed in a liquid, the weight of the body is reduced by an amount equal to the displaced liquid'. Now we will find this Law.

A cylinder is immersed in some amount of liquid is shown in figure 5.04 (This can be any object of any shape, but for convenience of calculation we took a cylinder). Let us suppose that the height of the cylinder is h , cross-sectional area of top and bottom of the cylinder is A . We imagine that the cylinder is immersed in such a way that the depth of upper surface is h_1 , and depth of lower surface is h_2 .

We have said many times that, pressure in a liquid (or gaseous) does not work in a definite direction. It works in all directions. Therefore the downward pressure acting on the upper surface of the cylinder is:

$$P_1 = h_1 \rho g$$

and the upward pressure acting on lower surface is:

$$P_2 = h_2 \rho g$$

Therefore, the downward force acting on upper surface and upward force acting on lower surface are respectively:

$$F_1 = AP_1 = Ah_1 \rho g$$

$$F_2 = AP_2 = Ah_2 \rho g$$

We do not have to think about how much force is exerted on the surrounding surface, because the force experienced by the cylinder from one direction is equal and opposite to the force from another direction and neutralize one another.

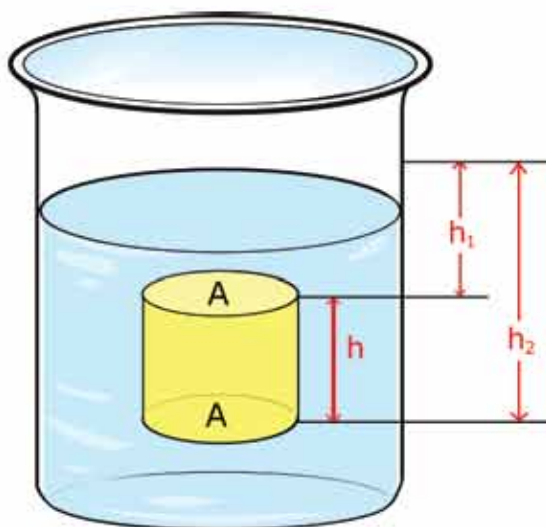

Figure 5.04: The weight of a body is reduced by an amount equal to the weight of the displaced water.

As the value of h_2 is greater than h_1 , so we see the value of F_2 is greater than F_1 .

Therefore the resultant force will be upwards and its value will be:

$$F = F_2 - F_1 = A(h_2 - h_1)\rho g$$

$$F = Ah\rho g$$

As Ah is the volume of the cylinder, ρ is the density of the liquid and g is gravitational acceleration, therefore the force exerted upwards is equal to the weight of the liquid which has the same volume as the cylinder. This is precisely known as the Archimedes Law. The upwards force is called buoyancy.



Do Yourself

Tie a big size potato or a fruit at one end of a rubber band and hang it, see how it is elongated. Now let the potato or the fruit be immersed into water, you will see the rubber band is compressed slightly. Because in the immersed condition the weight of the potato or fruit is less!

5.3.2: Floatation and Immersion of a Body

You have surely understood why an object floats and why an other object is immersed. You know an object experiences an upward force due to buoyancy which is equal to the weight of the water displaced by the object when it is immersed in water. The object will float if that force is greater than the weight of the object.

Just the portion of the object which is immersed so that it will displace water equal to the weight of the body, only that portion will be immersed exactly, the remaining part will not be immersed in water.

If the weight of the body is greater than the weight of the displaced water the body will sink in water. But it seems that the weight of the body when immersed is less than its real weight.

If the weight of displaced water can be made just equal to the weight of the object anyway, then the object remains there where it is put in water, it will not float above or even sink below. In our everyday life though it is not seen by us but for the movement of the submarine under water this is done.



Example

Question: If a piece of wood floats on water what percent of it will be immersed? (Density of wood $\rho = 0.5 \times 10^3 \text{ kg/m}^3$ density of water $\rho_w = 10^3 \text{ kg/m}^3$)

Answer: In order to float, the weight of the wood must be equal to the mass of the water displaced by the immersed part of the wood. That is, if volume of wood is V then its mass will be $V\rho$, and if the volume of the immersed part of the wood is V_1 , the mass of that amount of water is $V_1\rho_w$

Therefore, $V\rho = V_1\rho_w$

$$\frac{V_1}{V} = \frac{\rho}{\rho_w} = \frac{0.5 \times 10^3 \text{ kg/m}^3}{10^3 \text{ kg/m}^3} \times 100 = 50\%$$

Question: A piece of wood of mass 10 kg went to sea floating from the river. In the river water it was half immersed, how much of it will immerse in the sea? (Density of sea water, $\rho_s = 1.03 \times 10^3 \text{ kg/m}^3$)

Answer: Density of river water $\rho_w = 10^3 \text{ kg/m}^3$

If volume of wood is V and density is ρ then mass of wood will be $V\rho$

In river water the wood is half immersed $V\rho = \frac{1}{2}V\rho_w$

therefore, $\rho = \frac{1}{2}\rho_w = 0.5 \times 10^3 \text{ kg/m}^3$

If it is immersed by V_1 amount in the sea water,

$$V\rho = V_1\rho_s$$

$$\frac{V_1}{V} = \frac{\rho}{\rho_s} = \frac{0.5 \times 10^3 \text{ kg/m}^3}{1.03 \times 10^3 \text{ kg/m}^3} \times 100 = 48.5\%$$

Question: Let's suppose the mass of the gold crown of Archimedes is 10 kg in air and 9.4 kg when immersed in water. What is the density of the crown?

Answer: If the volume of the crown is V and density is ρ then

$$V\rho = 10 \text{ kg}$$

$$V\rho - V\rho_w = 9.4 \text{ kg}$$

$$V\rho_w = V\rho - 9.4 \text{ kg} = 10 \text{ kg} - 9.4 \text{ kg} = 0.6 \text{ kg}$$

$$V = \frac{0.6 \text{ kg}}{\rho_w} = \frac{0.6 \text{ kg}}{10^3 \text{ kg/m}^3} = 0.6 \times 10^{-3} \text{ m}^3$$

$$\rho = \frac{10 \text{ kg}}{V} = \frac{10 \text{ kg}}{0.6 \times 10^{-3} \text{ m}^3} = 16,666 \text{ kg/m}^3$$

Real density of gold is $19,300 \text{ kg/m}^3$, therefore it is understood that the crown is mixed by impurities.

5.3.3 Causes of Accidents on Waterways in Bangladesh

Bangladesh is a riverine country and the whole country is connected by canals and rivers. For this reason the waterway is one of the most common medium of communication. Boats, trawlers, launches or ships are involved in accidents as like as other vehicles and human death occurs. There may be many reasons for accidents on waterways. Of them the principal reasons are: disastrous weather, collision with each other, fault of driver, fault of machinery, fault of design, carrying more passengers than the capacity, irregular storage of accessories etc.

Following weather signals properly, it is possible to get rid of danger of disastrous weather greatly. But suddenly the vessel can be affected by norwesters and fall in danger. In these circumstances the experience and responsibility of the drivers play a vital role. Another major reason of accident on waterways are collisions: collision between two boats, collision with the jetty, collision with the bottom of the river or with a shoal, all of them result in different types of accidents.

If the equipment of a vessel are not stored properly it becomes the reason for the

accident. By changing the design of a vessel to carry large number of passengers, without authorization, may be pushing it towards an accident. For more profits if excess passengers are carried in a vessel then, due to the change of the center of mass of the vessel, a big accident may also occur. During disastrous weather accessories may be displaced due to rolling of the vessel in big waves and thus the center of mass can change and accidents may occur.

5.3.4 Pascal's Law

We have shown many times in this chapter that if pressure is applied on a liquid, it is transmitted towards all directions. You will understand that it is normal if you think a bit. Because if the pressure is not transmitted into the whole liquid then the pressure experienced in one part will be more and it will be less in another part. Therefore if we imagine a cross sectional area then force applied from one direction will be more than the force from an other direction and due to this force the liquid will flow until the pressure becomes equal. Pascal expressed this in the form of a law, that is stated below:

Pascal's Law: If pressure is applied on a liquid or a gas enclosed in a container from outside, then this pressure is transmitted equally and acts perpendicularly on the surface of the container in contact with the liquid or gas.

Applications of Pascal's Law:

Using Pascal's law some interesting machines can be fabricated. In figure 5.05 a machine like that is shown. Here two cylinders are connected by a pipe. Let's suppose cross sectional area of one cylinder is A_1 and that of another cylinder A_2 , and you have applied force F_1 on the cylinder of cross sectional area A_1 . Then your applied pressure is

$$P = \frac{F_1}{A_1}$$

Now this pressure is transmitted through the liquid in all directions and it will also be applied on the cross sectional area of the second cylinder.

Therefore the amount of force applied on the second cylinder will be

$$F_2 = PA_2 = F_1 \left(\frac{A_2}{A_1} \right)$$

Therefore, you see amazingly that if the magnitude of (A_2/A_1) is 100 then you will get 100 times more force on the second cylinder than the force you applied on the first cylinder!

This process is very effective and is used to control very large factories and aircrafts. But keep in mind; it is the principle of increasing forces. In this process energy cannot be increased at all. You will get back the same amount of energy on the second cylinder that you have applied on the first cylinder.

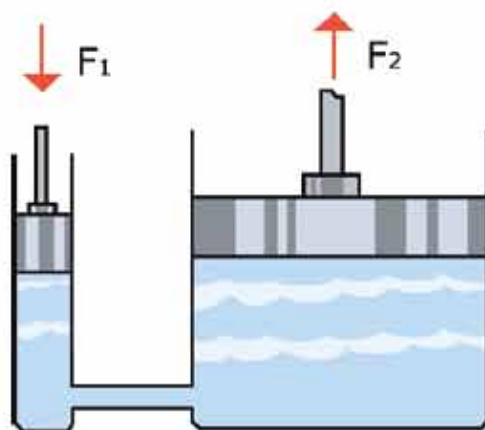

Figure 5.05: Force F_2 is obtained by applying force F_1 , which depends on the cross section on which the force is applied.



Example

Question: Show that you are getting back the same amount of energy which is applied though force is increased.

Answer: Let's suppose force F_1 is applied on the smaller piston and the piston moves by a distance l_1 .

Therefore, amount of work done $W_1 = F_1 l_1$

Force on the bigger piston $F_2 = F_1 \left(\frac{A_2}{A_1} \right)$

As the water displaced by the smaller piston moves the larger piston by a distance l_2 by pushing, therefore

$$l_1 A_1 = l_2 A_2$$

Distance travelled by the larger piston: $l_2 = l_1 \left(\frac{A_1}{A_2} \right)$

Therefore, amount of work done: $W_2 = F_2 l_2 = F_1 \left(\frac{A_2}{A_1}\right) l_1 \left(\frac{A_1}{A_2}\right) = F_1 l_1$

i.e equal to the work done by the smaller piston.

5.4 Air Pressure

Air has a certain pressure (Figure: 5.06). We do not feel this pressure distinctly because a pressure is also exerted outside from inside of our bodies. So these two pressures neutralize one another. There is no air in space, so there is no pressure of air, so there is nothing to neutralize the inner pressure of our body and in such an environment human bodies may explode instantly due to this inner pressure. For this reason the astronauts always wear pressure protected space suits. The pressure on the earth surface is 10^5N/m^2 , which means if you imagine an area of 1m^2 on the earth surface, then the weight of the column of air on it is 10^5N , this is approximately the weight of an elephant !

Here, you have to understand something very clearly. It is true, weight is a force and this force acts downwards. Force is a vector, so it has both magnitude and direction. Pressure is not a vector, it has no direction, so it is same in all directions at any place. The place where you are standing or sitting now, the pressure which air exerts on you is the same in left, right, up, down or in all directions. It is true for air or liquid for all times.

If an air-tight casket made of thin tin or aluminum can be made airless in any way, then it will be folded or twisted, because in normal condition, the outer air pressure was balanced by inner air pressure of the casket in turn. After evacuating the inside air by pumping, there is nothing inside to resist the outer air pressure. So the outer air pressure will twist the casket (figure 5.07).

Air column



Figure 5.06: The pressure of air comes from the weight of the air column.

You will observe that the casket will not be twisted only from the upper side, it will be twisted from all directions. If the pressure comes only from the upper side the casket will be twisted only from the upper side. As the pressure is same in all directions, so it comes from all directions, and the casket is twisted from all directions.

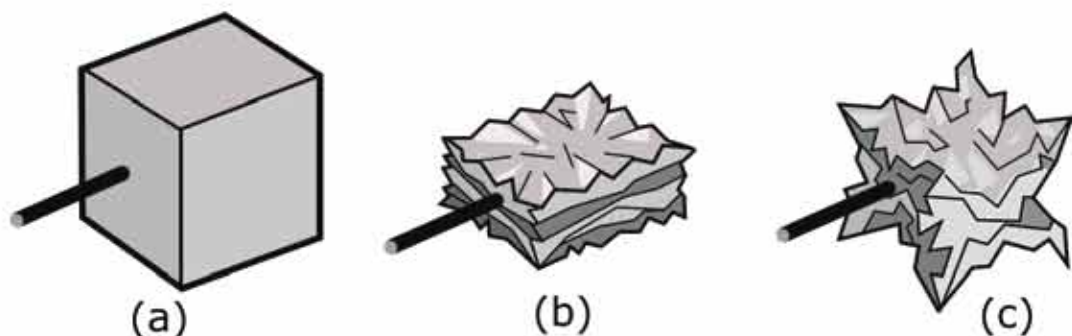

Figure 5.07: (a) After evacuating the air from the cube shown in (a) by pumping, if the air exerts pressure only from the upper side, the cube would become flat as shown in (b). But the pressure comes from all directions so the cube is compressed as like the picture shown in (c)



Do Yourself



Figure 5.08: Due to air pressure the water bottle is folded and twisted

Take an empty one liter water plastic bottle. Pour some boiling water carefully in the bottle and shake the water. When the whole air inside the bottle becomes hot, close the cap of the bottle tightly. Now wait for a while or keep the bottle in the flow of cold water and make it cold. Some vacancy will be created inside the bottle and it will be folded and twisted due to the pressure of the outside air. (Figure. 5.08)

The pressure on the surface of the earth originates from the weight of the air column. So if we rise above then the height of the air column above us will decrease, the weight will also decrease, due to this the air pressure will also decrease there. The matter is true and how this air pressure decreases with height is shown in Figure 5.09. What you have to observe separately is that the air pressure has decreased by half after reaching a height of five kilometer. Generally, one may ask by reduction of pressure why does it not become zero after the next five kilometer? There is a specific reason behind it. Air or gas can be compressed by putting a pressure. So on the surface of the earth, air becomes most compressed where the air pressure is maximum i.e. the density of air is maximum there. As we go above, the pressure of air will reduce, density of air will decrease as well.

There are many practical aspects of reducing density of the air with height.

When a plane flies in the sky, the friction of air acts as a big problem. The higher we go, the density of wind will be reduced, and friction will also be reduced. Therefore, really big planes try to fly through as high as possible in the sky. Generally it may seem that why do the planes not fly height at very big as then the friction will be decreased further. The reason is that the planes need powerful engines to fly and oxygen is required to burn the fuel of those engines. The amount of oxygen is less where the density of air is less as at great heights. So at higher altitudes the engine of the plane will not work due to the shortage of oxygen.

Those who climb to the peak of mountains face the same problem. The higher they climb the problem of less oxygen due to reducing density of air is more than the problem of less air pressure. For this reason those who climb mountains have to practice not only how to survive in less oxygen but also have to learn how to

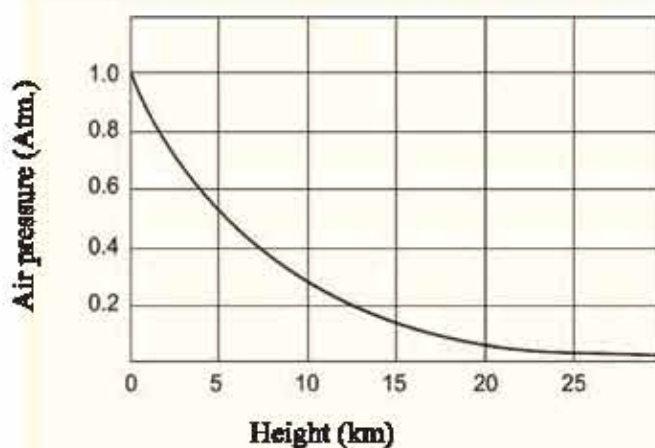

Figure 5.09: Air pressure reduces with height.

do very hard job like mountain-climbing. So, they have to prepare their bodies.



Example

Question: How much oxygen is there at the peak (29,029 ft) of the Everest?

Answer: 29,029 ft = 8,848 m

We see from the graph that the pressure of the air at this height is only 35% of the pressure of air at the earth's surface. Therefore the amount of oxygen there is approximately 1/3 of the oxygen on the earth surface.

5.4.1: Experiment of Torricelli

You have surely had cold drinks with straws. Have you ever thought how the cold drinks reaches your mouth when you sip? Really this occurs due to the pressure of the air. It would be very easy to understand if you try to drink the cold drinks with a 10.5 meter long straw. (This is not realistic at all. But acknowledge it for the sake of argument!) Then you would discover that the drinks rise 10.3 meter and stop suddenly. No matter how much you try the drinks do not rise any more. (We are assuming that the density of cold drinks is close to the density of water!)

Mercury is not a liquid to take into mouth but for the sake of argument imagine you try to sip it to get it in your mouth with a straw. If the straw is longer than 76 cm, you will discover that the mercury has stopped just after rising 76 cm. You try to sip the mercury does not rise any more! Density of mercury is 13.6 times more than the density of water, so elevated levels of more but the mercury is 13.6 times lesser than the water.

Cold drinks will not rise up through a straw normally if we take a straw in the mouth and put it into the bottle. Because the air pressure within your mouth is the same as the air pressure of the liquid in which the straw is immersed. The two pressures are equal so there is no effective force inside it. Now if you sip, which means you try to create a vacancy in your mouth, then the air pressure becomes low there. Then the liquid comes above through the straw due to the air pressure on the liquid surface.

Scientist Torricelli did this experiment of the pressure of air using mercury in the year 1643. He did not try to make the mercury rise with a straw by mouth. He filled a one ended tube with mercury and he put it in a mercury filled container in an inverted way. After falling continuously the mercury stopped at a height of 76 cm. The vacancy which you try to create while sipping liquid, this vacancy was created in the upper portion of the glass tube. Air is exerting pressure on the mercury and that pressure being transmitted everywhere of the liquid, even down the tube. There is no leakage above the tube, so air cannot exert pressure through that side. Therefore to equalize the pressure there is only a pressure under the tube, which is the pressure due to the weight of 76 cm mercury column!

The instrument by which air pressure is measured is called a barometer (Figure: 5.10) and till now the pressure of the air is measured by a barometer which uses the process of Torricelli. The height of the mercury column becomes more than 76 cm if the air pressure increases and if pressure decreases the height become less than 76 cm.

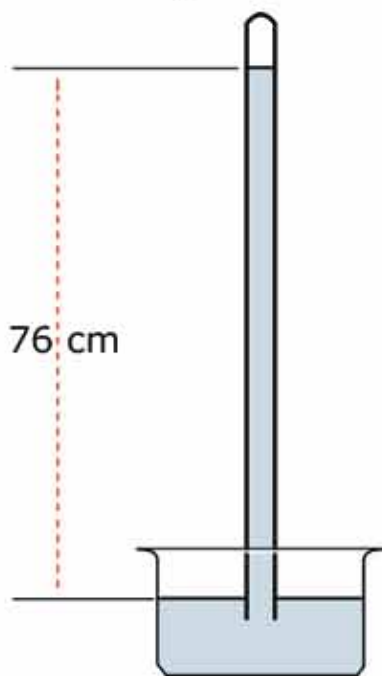

Figure 5.10: Mercury becomes stationary just at 76 cm height due to air pressure.

5.4.2 Air Pressure and Weather

Weather has a close relationship with air pressure. You have certainly heard many times in weather news about the creation of depression in the sea, which means air pressure has been decreased there. Then air starts to come from the nearby areas of high pressure to the low pressure area and sometimes a spin is created, in special situation that spin creates cyclone. You certainly know the news of horrible cyclones in our country.

When you will read about heat and temperature in the next chapter, you will know that if the temperature of air is increased, then it expands, as a result density and pressure decrease. Air pressure decreases more effectively if the

amount of vapor inside it increases. Vapor is water, in a molecule of water there is an oxygen and two hydrogen atom and molecular mass of water is $(16+1+1=)$ 18. The main element of air is nitrogen (atomic mass 14), being created by two atoms it's molecular mass is $(14+14=)$ 28 and oxygen (molecular weight 16), is also created by two atoms, so, it's molecular mass is $(16+16=)$ 32, which is much more than the molecular mass of water. So, when there is vapor in the air, water of less molecular mass takes the place of nitrogen and oxygen of higher molecular mass and so the density of air decreases. If the density of air decreases, the air pressure also decreases. So, it is possible to predict about the local weather seeing the air pressure on a barometer. If the barometer shows high pressure then it is understood that the air is dry and the weather is good. If the pressure starts to decrease then it is understood that the quantity of vapor is increasing. If pressure low then air from the nearby areas will come quickly and storm and rain will start.

5.5 Elasticity

All of you must have, one time or another, elongated a spring or a rubber band by pulling on it and then releasing it. You have certainly noticed that after releasing the spring or the rubber band it regains its previous length. In physics, pulling is termed as 'applying force' and the change of the length is termed as 'deformation'. The word deformation is taken negatively in our daily life. But you should not take it negatively here. It is just a change in condition!

Therefore, you understand that when a force is applied to an object, a deformation happens inside it (and for this deformation, a counter force is created). If the force is withdrawn, deformation stops and the object comes back to its initial condition. This property of a substance is called elasticity. But it should be remembered that the quantity of the applied force has a limit. If the limit is crossed, the substance will not be able to come back to its initial condition. A permanent deformation could take place. This limit is termed as the elastic limit. After bending a rod slightly, if it is released then it becomes straight. If it is bent too much then it remains curved and does not become straight. Therefore we can state this like:

Strain: The relative change in length or shape which is made by applying a force from outside is called strain. Therefore, if force is applied on an object of length L_0 , and the changed length becomes L then it's strain is: $\frac{L - L_0}{L_0}$

It is seen that the deformation has no unit, it is only a number.

Stress: The force per unit area that develops within a substance due to deformation is called stress.

If a force is applied on a body of cross sectional area A and as a result deformation occurs, then if this deformation develops a resistive force F , then stress is:

$$\frac{F}{A}$$

You see it is similar to pressure and its unit is Pa or Pascal.

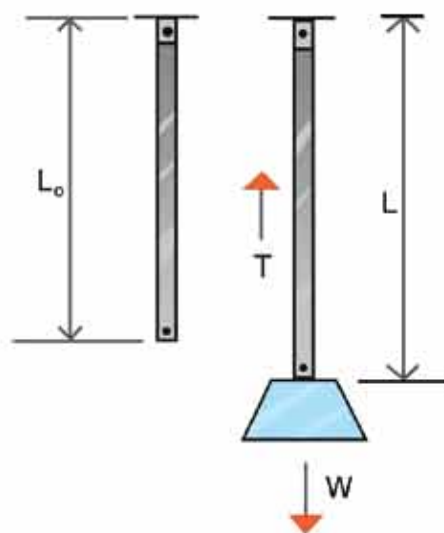

Figure 5.11: Deformation occurs in a bar if stress is created by applied force.

Hooke's law: If we have understood stress and strain, it is easy to understand Hooke's law. According to this law, 'within elastic limits stress is directly proportional to strain'.

$$\text{stress} \propto \text{strain}$$

Therefore,

$$\text{Stress} = \text{constant} \times \text{Strain.}$$

That is, there is a constant relating stress to strain for each material; the name of this constant is modulus of elasticity.

It will be easy to understand if we discuss two things:

- (i) Let us suppose that the length of a wire of cross-sectional area A is L_0 , a body of weight W is hanged from it and due to this hanged force the wire is elongated from L_0 to L (Figure 5.11). This elongated length creates a counter force T in the wire (Here the letter T is used to mean the word 'tension'. Generally, when a wire is pulled then the force acting in it is named as tension). Therefore Stress is T/A and strain is $\frac{L - L_0}{L_0}$

Table 5.02: Young's modulus of different substances

$$\text{Therefore, } \frac{T}{A} \propto \frac{L - L_0}{L_0}$$

$$\text{Or, } \frac{T}{A} = Y \left(\frac{L - L_0}{L_0} \right)$$

Substance	G-Pa
Rubber	0.01-0.1
Bone	9
Wood	10
Glass	50 - 90
Aluminum	69
Copper	117
Iron	200
Diamond	1220

Here, Y is a constant. The name of this constant is Young's modulus. As strain has no unit, the unit of Y is Nm^{-2} . Young's modulus of some substances are given in the table 5.02.



Example

Question: How does the length of a substance change with the change of the value of the Young's modulus?

Answer: Rate of change of length

$$\frac{L - L_0}{L_0} = \frac{1}{Y} \left(\frac{T}{A} \right)$$

Therefore, if T/A remains the same, the higher the value of Y is, change in length will be less.

(ii) Let us consider, in normal condition a gas of volume V_0 is contained in a cylinder.

Due to the application of pressure P , its volume is reduced to V (Figure 5.12).

Here P is the stress and the Strain is: $\frac{V - V_0}{V_0}$

Therefore, we can write

$$P \propto \left(\frac{V - V_0}{V_0} \right)$$

$$P = B \left(\frac{V - V_0}{V_0} \right)$$

Here B is a constant and is called the bulk modulus of elasticity. Unit of B is Nm^{-2} or Pascal.

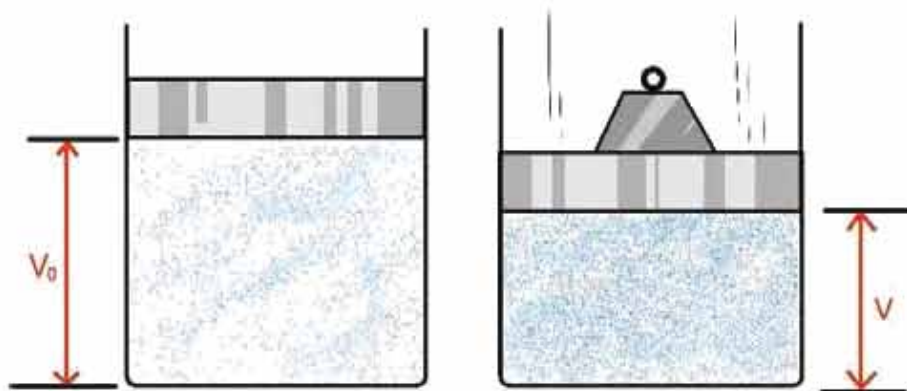

Figure 5.12: If pressure is applied in confined air, the air is compressed.

5.6 Three States of Matter: Solid, Liquid and Gas

You certainly know that, everything of the universe is made of molecules! (In fact, molecules are not fundamental particles, molecules consist of atoms, atom consists of electrons and nucleus, nucleus consists of protons and neutrons, proton and neutron consists of quarks and the scientists are assuming that electrons or quarks are made of strings!). Since, the properties of a matter exist in molecules, molecules are considered the smallest unit of matter. For example, all properties of water exist in a water molecule, but when it is split into atoms it does not exist as water. There will be one oxygen and two hydrogen atoms, both in the gas form. Whether the substance is solid, liquid or gas depends on how molecules are arranged within the matter (Figure: 5.13). The most

familiar example of it is water; it can exist in three states, e.g. solid, liquid and gas. Whether it is ice, water or vapor depends on how the molecules are within it.

When a substance remains in the gaseous state, then its molecules are free, the distance between one another is very large. When the substance is in a liquid state, then though the molecule remains comparatively closer but they can move with respect to one another. In solid state, molecules remain the closest, but can not move with respect to the other.

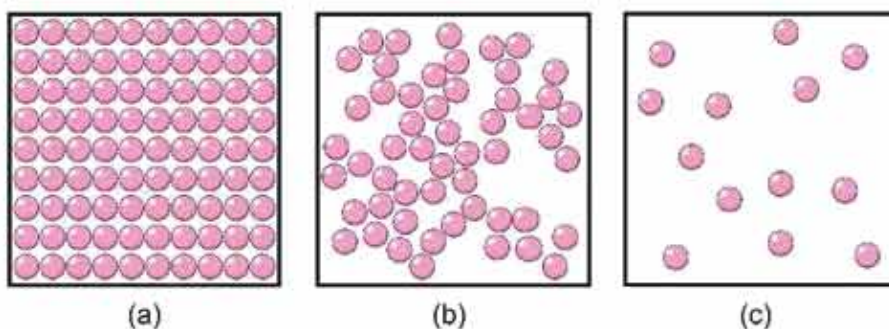

Figure 5.13: (a) solid (b) liquid (c) gas.

The distance among the molecules of a gas are very large. Those substances have no regular volume and shape. Molecules in a liquid remains closer and they have a particular volume but no regular shape. In a solid, molecules are very close and they are almost in contact with each other, so they have a definite volume and a regular shape.

In a gas, molecule can move freely, in liquids the molecules vibrate, and one can pass through from one side to the other, in solids though the molecules can vibrate but they can not change their position.

Normally we cannot see the molecules of solids, liquids or gases, we see it as solid, liquid or gas. The properties of molecules which have been mentioned above, are exhibited in their solid, liquid or gaseous state too.

Gas : Molecular properties	Reflection in gases
Molecules can move beside one another	Spread through the total volume of the container in which it is kept.
Distance among the molecules is more, there exists vacant space	Gas can be compressed by pressure
A molecule can move with respect to another	Gas can flow easily
Liquid: Molecular properties	Reflection in liquids
Molecules can move beside one another	Can flow easily, gain the shape of the container in which it is kept.
Molecules are very close together so there is no vacant space	Liquid cannot be compressed by applying pressure
Solid : Molecular properties	Reflection in solids
Molecules are rigid in their own position	There is a definite shape
There is no distance among the molecules	Can not be compressed by pressure
Molecules are confined to their own positions	Cannot be made to flow

5.6.1 Molecular Kinetic Theory of Matter

If a solid substance is kept on a table, the solid exerts a kind of pressure on the table, on the area of the table which it touches. If we want to put some liquid on the table instead of solid, it will not work; the liquid will spread over the table. Liquids have to be contained in a pot and the liquid exerts pressure not only on the bottom of the container but it exerts pressure on the walls of the container in all directions. (If a hole is created in the wall of the container, the liquid will come out through this hole due to the pressure of liquid.) If we want to put gas then it is not possible to put it in an open container, then it is to be stored in a bound region and the gas will exert pressure on the bound surface in all directions. Gas is contained in a balloon. If we make a hole on a balloon, air will come out through this hole due to the air pressure.



Do Yourself

Put a piece of scotch tap on an air filled balloon. Now make a hole on the balloon through the scotch tap with a needle. You will see that the balloon does not burst but air is coming out.

We mentioned about pressure of gas but didn't explain its reason. We can explain the reason of pressure by the molecular kinetic theory. If a gas is kept in a closed space then it puts a pressure on the walls of the container, this can be explained with the help of the molecular kinetic theory of substance. In a closed region the molecules of a gas starts moving randomly and every time it hits the walls of the container it goes back due to reflection. Therefore a gas molecule hits the wall with a particular momentum, and returns back with a different momentum. You know to change the momentum of an object, a force has to be applied on that object. Hitting the wall, the gas molecules apply a force on the wall. According to Newton's third law, the wall also applies a counter force on the molecule thus reflecting the molecule.

An enormous number of molecules thus hit the walls of the container and this combined force appears as the pressure of the gas. If the temperature of the gas is increased, then the kinetic energies of the molecules will increase and the molecules will hit the wall harder. This means the pressure will be increased. We will see in the next chapter that due to the application of heat, temperature increases and as a result pressure also increases.

5.6.2 Fourth State of Substance

Despite solids, liquids and gases, the three different states of matter, substances may have a fourth state named plasma. We know the number of the positively charged protons in the nucleus of a molecule or an atom is equal to the number of negatively charged electrons outside it. That's why the combined charge of a molecule or atom is zero. Under special conditions a molecule or an atom can be ionized, one or more electrons of some atoms can be made free, then separately the atoms do not remain charge neutral. A kind of a mixture of ions and electrons is made. Though it stays like a gas but all of the properties of gas are not true for it. Like we know, a gas has no fixed shape but a fixed shape of plasma can be made by a magnetic field.

Gases can be turned into plasma by giving excessive heat; plasma also be made by a powerful electric field. In our house, plasma is created in a tube light. There is also plasma in the luminous advertisement of neon light. The light which is seen during thunder is also plasma and the substances which remain in the far stars is also in the plasma state. At present, we use nuclear energy in fission process by breaking a heavy nucleus. We try to use plasma for creating energy in fusion process combining the light nucleuses and now this is a very important field of research in physics.



Do Yourself

Density of a substance

Objective: Determine the density of a substance

Apparatus: Spring balance, a solid which can sink in water, water in a pot.

Theory: Dividing the mass of a body by its volume, density is measured. Mass of the body can be measured by a spring balance. It is possible to determine the volume of the body using the Archimedes law. After immersion, the decrease of the mass in grams is the volume in cc (cm^3).

Procedure:

1. Determine the mass of a body using a spring balance.
2. Tie the body with a thread and hang it from a spring balance and determine the mass keeping the body inside the water.
3. Determine the density of the body.

Table: To determine the density of the matter

Number of observations	Mass of the solid substance M_1 gm	Mass of the solid substance when immersed M_2 gm	Volume of the solid $M_1 - M_2$ cm^3	Density of the substance $\frac{M_1}{M_1 - M_2} \frac{\text{gm}}{\text{cm}^3}$



Exercise



General questions

1. A piece of ice is floating in glass water, once the ice melts the height of water in glass will increase or decrease?
2. It is possible to float a whole ship in a few buckets of water. How?
3. Suppose you sit on a boat in a swimming pool with a big stone. You drop the stone in the water of the swimming pool from the boat. The height of the water in the swimming pool will increase or decrease or remain the same?
4. Hermits claim that they can lie down on a bed of nails (Figure 5.14). You can do the same, if you want, why?
5. If the glass tube of Torricelli's barometer is twisted instead of straight then will it work ?
6. What is the relation among force, pressure, area?
7. What is density? What is its unit?
8. What is atmospheric pressure?
9. Is Torricelli's vacuum a vacuum in reality? Explain
10. Establish a relation between pressure and height of a liquid.



Figure 5.14: A Hermit is sitting on a bed of nails.



Mathematical questions

1. Density of air is 0.0012 gm/cm^3 , density of gold is 19.30 gm/cm^3 , if 1 kg gold is measured by a balance, what will be its real mass?

2. What will be its height if kerosene is used to make a barometer instead of mercury?

(Density of kerosene is 0.8 gm/cc)

3. A crown of gold and an equal weight of pure gold are hung from the two sides of a bar and then immersed into water (Figure 5.15). If we find that in water the weight of the crown is less, then what will you say about the crown? Is it pure or impure? Why?

4. Two water filled cylinders are connected by a pipe. The cross sectional area of the two cylinders are 1 cm^2 and 1 m^2 and two pistons are attached with them. A person of weight 70 kg is sitting on the bigger piston. How much force will you have to apply on the smaller piston if you want to lift him?

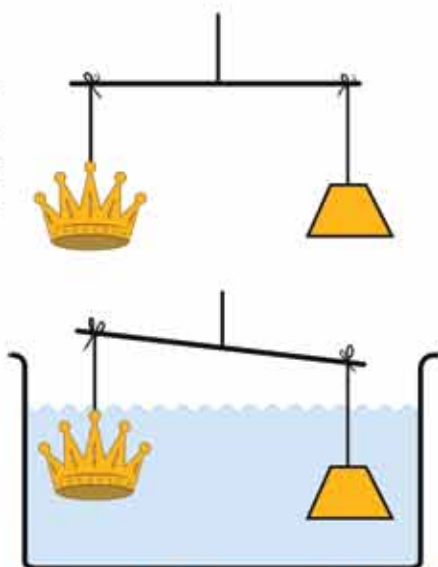

Figure: 5.15: Crown of gold and pure gold is immersed in water

5. A weight of 10 kg is hung from a metal rod of 0.5 m length and 0.01 m^2 cross sectional area. The elongated length is 0.501 m . What is the Young's modulus of this metal rod?



Figure: 5.16 : A man is lifted up by putting pressure on a hydraulic press



Multiple choice questions

Put the tick (\checkmark) mark on the correct answer

- What is the name of the apparatus used to measure the atmospheric pressure?
 - Thermometer
 - Barometer
 - Manometer
 - Seismometer.
- The amount of liquid pressure is –
 - proportional to its depth
 - proportional to area.
 - Inversely proportional to density
 - equal to acceleration due to gravity.
- What is the name of the fourth state of matter?
 - Gas
 - Plasma
 - Solid
 - Liquid.

Give answer to question no. 4 & 5 from the figure

- How much pressure will be felt at the bottom of the container?

- | | |
|------------|-------------|
| (a) 98 Pa | (b) 980 Pa |
| (c) 196 Pa | (d) 1960 Pa |



Figure 5.17

- If force F is applied on the free surface of the container, then this force-
 - will exert a pressure at the bottom of the container only.
 - will exert a pressure on the curved surface of the vessel only.
 - will exert a pressure in all directions of the vessel.

Which one of the below is correct?

- | | |
|---------|------------------|
| (a) i | (b) ii |
| (c) iii | (d) i, ii, & iii |



Creative questions

Answer the following questions by observing the figure:

- What is density?
- Explain the cause of the floatation of the body as shown in the figure.
- Determine the density of the body.
- Explain the effect of gradual increase of temperature of the liquid.

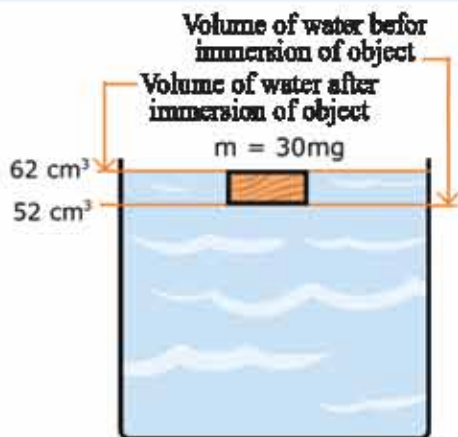

Figure 5.18

2. Fahim clamped one end of a rubber band of length L_1 on a wall and hung a mass M at the other end. He saw that the rubber band elongated to a length L_2 . It regained its initial condition after removal of the mass. He recorded the result of his experiment in a table as shown below.

Mass (kg)	0	0.4	1	1.4	2.2	3	4	5
Length with mass L_2 (cm)	10	12	15	17	21	25	30	36
Length after removal of mass L_1 (cm)	10	10	10	10	10	10	10.2	10.6

- Write Hooke's Law .
- How stress leads to strain?
- If $M=2.7\text{ kg}$, then $L_2=?$ Calculate it.
- Draw a picture of a machine which can be used daily by using the information in the table.

Chapter Six

Effect of Heat on Matter



Heat is a kind of energy. From the concept of energy we may think that heat flows always from higher heat energy to lower heat energy, but it is not true. In which direction heat will flow, depends on the temperature. In this chapter we will see how we can measure heat or temperature and what is the relation between them.

Actually heat energy comes from the motion of molecules, atoms or their vibrations. If the vibration of molecules of any solid object is increased to a great extent, then molecules may go far from another one, that is, a change of state may occur. In this chapter we will discuss the effect of heat on solids, liquids and gases.



By the end of this chapter we will be able to-

- explain heat and temperature.
- explain the thermal properties of matter.
- analyse the relationship among Fahrenheit, Celsius and Kelvin scale.
- explain the increase in temperature with the increase of internal energy of the substances.
- explain the thermal expansion of substances.
- explain the expansion in length, area and volume of a solid.
- explain the real and apparent expansion of liquids.
- explain specific heat and heat capacity.
- explain the principle of measurement of heat.
- explain the effect of heat in changing the state of matter.
- explain melting, vaporization and condensation.
- explain melting and boiling point.
- explain the effect of pressure on melting point.
- explain boiling and evaporation.
- explain the latent heat of fusion and vaporization.
- explain the cause of cooling and evaporation.
- explain the influence of factors on vaporization.

6.1 Heat and Temperature:

Heat is a kind of energy. We have seen that energy can do work. By applying force it is possible to displace a body in the direction of the force, for example heat is produced by burning fuel oil in a train or a car and this produced energy creates motion in the train or car. So this new form of energy is called heat energy like light, electricity or kinetic energy.

It is interesting that if we could see on the molecular level i.e., looking at any substance if we see its molecules, we should call it "kinetic energy" instead of the "heat energy". Because what we mean by heat energy is actually nothing but the combined kinetic energy of the molecules of a substance. When the molecules of a solid are heated then the molecules vibrate about their fixed positions. The more the molecules are heated, the more the vibration increases. If the molecules are heated enough the molecules become free by overcoming the intermolecular forces among them. Then we call it a liquid. Then the molecules move randomly among themselves. Since the molecules are in motion, they have kinetic energy. The more the molecules are heated, the faster they will move. If the molecules are heated more, they may be completely free from their intermolecular forces. Then we call it a gas. The more a gas will be heated, the faster its molecules will move. The more the velocity, the more the kinetic energy.

Since we cannot see the molecules with our naked eyes, we cannot see their movement, so we try to understand the whole thing indirectly, we call it heat energy and try to explain the states of matter considering it as temperature. So we can say that the energy which is obtained due to molecular vibration or motion of a substance is called heat. As it is a form of energy like other energy, so its unit is Joule (J). There is another unit of heat which is calorie (cal). The amount of heat energy required to increase the temperature of 1 gm of water by 1°C is called 1 Calorie. 1 Calorie is equal to 4.2 J. You have heard about the word "calorie" which is used in case of food. Food Calorie means actually the amount of energy obtained from a definite quantity of food and the unit for this is kcal or 1000 calorie. But we will not worry about this now. Here we will discuss heat energy not energy gained from foods.

6.1.1 Internal Energy

If we accept heat as energy, the next thing we need to know how heat energy is transferred from one place to another. Generally we think that energy always flows from higher energy to lower energy. The amount of heat energy that is contained in a glass of water is much more than that of a small hot pin. But if we put the hot pin into the water, a small amount of the energy of the pin will transfer to the water of the glass. Because of this, the flow of heat energy does not depend on the amount of heat, it depends on the temperature. If two bodies of different temperatures come in contact with each other, always heat transfers from the body of higher temperature to the body of lower temperature until the temperature of the two bodies becomes equal.

But we have not yet defined the quantity called “temperature” yet. But it is used so much in daily life that nobody faces problems in understanding what temperature means. According to physics we can say that it is the measure of average kinetic energy of the molecules of matter. From our experience we can say that temperature is the thermal state which indicates whether an object

absorbs or rejects heat when it comes in contact with another object. To understand this, we can compare it with the height of the surface of water in (Figure 6.01).

If the heights of the upper surface of water in the two containers are different, and they are connected with a pipe, the flow of water will not be determined by which container contains more or less water. Water flow will depend on the height of the upper surface of water of the containers. Always water will flow from higher height to lower height until the two heights become equal. Here we can compare the amount of water with heat energy and the height of the surface of water with temperature. It is also true in case of temperature that the heat flows until the temperature of the two objects becomes the same.

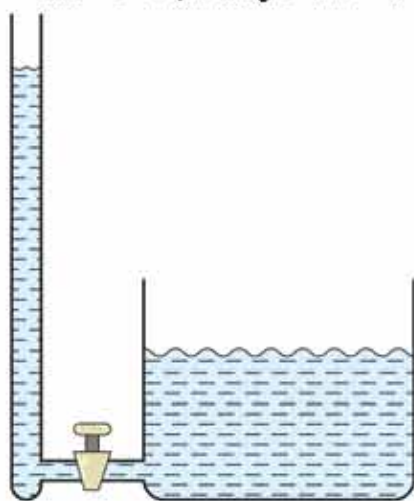

Figure 6.01: Temperature is as like the height of water and heat is as like the volume of liquid

6.2 Thermometric Properties of matter

To measure the temperature special properties of special substances are used. The property of a substance which changes with temperature and, measuring the change accurately, the temperature can be measured, is called thermometric property. The property of a substance which is used to measure the temperature is called thermometric property. You have seen mercury thermometer that measures our body temperature. Here mercury is the thermometric substance, the volume expansion of mercury is its thermometric property.

There is also an alcohol thermometer except mercury thermometer in which alcohol is the thermometric substance and the expansion of alcohol is the thermometric property. In a gas thermometer, gas is the thermometric substance and the pressure of the gas at constant volume is the thermometric property. As the resistance of metal changes with temperature, so the resistance also is used as the thermometric property. Different thermometric substances are effective at different temperatures, so to measure the very high or very low temperature the special thermometric property of a special thermometric substance has to be used. Copper and Constantan metals are used as thermometric substances. If two junctions of different metals are kept at different temperatures, it produces an emf and by measuring this, the temperature can be calculated. This thermocouple is used in industries on a large scale because it can measure the temperature from -200°C to 1000°C .

If we get the idea of temperature perfectly, we have to know its unit in addition to, the important question of how we will measure the temperature. The conventional unit of temperature is Celsius ($^{\circ}\text{C}$), generally it is said that on this scale at one atmospheric pressure and at the temperature at which ice melts is called 0°C and at the temperature at which water boils is assumed to be 100°C . But it is interesting to know that when scientist Celsius introduced this scale of temperature, he assumed the temperature of boiling water as zero degree and the temperature of fusion of ice as 100 degree; opposite to the present scale!

Although we use the Celsius scale of temperature in our daily lives, its international unit is Kelvin (K). Adding 273.15°C with the reading of Celsius scale we get the reading of Kelvin scale. If we consider only the difference of temperature, there is no difference between Celsius and Kelvin scale. That is, the increase in temperature by 10°C is the same as the increase in temperature by

10 K. But if it is asked that what is the temperature of this room, the answer is 30°C , but in Kelvin scale it will be $(30+273.15)=303.15\text{ K}$. You may think that the two scales are completely same but the difference between the readings of the two scales is 273.15°C , what is the reason behind this? The reason behind this is very wonderful. Generally, we may think that we can imagine any

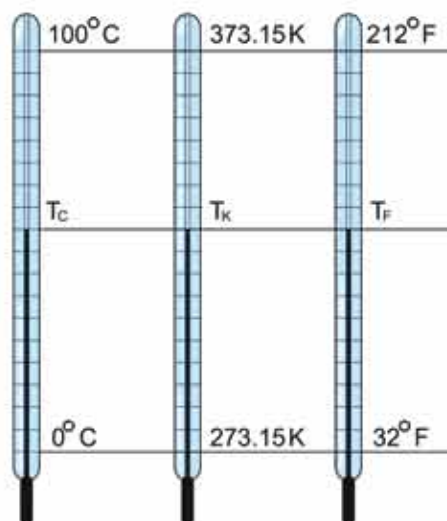

Figure 6.02: Celsius, Kelvin and Fahrenheit scales of temperature

temperature i.e., it may be very high or very low, but actually it is not true. There is no problem in imagining a temperature as high as you wish but it is not possible to imagine a temperature as low as you wish. There is a lowest temperature and any temperature below this is not possible. Not only this, we can reach near this temperature but we can never reach at this temperature. This temperature is called the absolute zero temperature. On Celsius scale the value of this temperature is -273.15°C . Therefore, in Kelvin scale its value is zero Kelvin. In other words it is said that the Kelvin scale has been made considering the

absolute zero temperature as zero Kelvin.

To make any scale of temperature two certain temperatures (or fixed points) are needed. In the Kelvin scale one is absolute zero which is taken as zero degree. Another one is the triple point of water. At this temperature and at a certain pressure (0.0060373 atm) ice, water and water vapour can exist together, so this temperature can be defined very accurately. In the Celsius scale its value is 0.01°C and to make the similarity with Celsius scale its value is 273.16° in Kelvin scale.

Besides, the Kelvin and Celsius scales there is an another scale called the Fahrenheit scale in which the temperature of fusion of ice and vaporization of water are 32°F and 212°F respectively. In the figure 6.02 three scales are shown for comparison, where 0°C is equal to the temperature 273.15 K , sometimes we take this as 273 K in our daily lives. This does not cause a major problem in our daily lives.

6.2.1 Relation among different scales:

A definite temperature is expressed in the Celsius, Kelvin and Fahrenheit scale as T_C , T_K and T_F respectively. Then we can write:

$$\frac{T_C - 0}{100 - 0} = \frac{T_K - 273.15}{373.15 - 273.15} = \frac{T_F - 32}{212 - 32}$$

Or,

$$\frac{T_C}{100} = \frac{T_K - 273.15}{100} = \frac{T_F - 32}{180}$$

The readings of Kelvin and Fahrenheit scales with respect to T_C will be respectively:

$$T_C = T_K - 273.15^\circ$$

$$T_C = \frac{5}{9}(T_F - 32)$$



Example

Question: At which temperature are the readings in Celsius and Fahrenheit scales equal?

Answer: The relation between Celsius and Fahrenheit scale is

$$T_C = \frac{5}{9}(T_F - 32^\circ)$$

$$9T_C = 5T_F - 5 \times 32^\circ$$

If T_C and T_F are equal then we get:

$$4T_C = -5 \times 32^\circ = -160^\circ$$

$$T_C = -40^\circ$$

That is, the temperature which shows -40° C the same temperature also shows -40° F.

Question: At which temperature are the readings in Kelvin and Fahrenheit scale equal?

Answer: The relation between Kelvin and Fahrenheit scale is

$$T_K - 273.15^\circ = \frac{5}{9}(T_F - 32^\circ)$$

$$9T_K - 9 \times 273.15^\circ = 5T_F - 5 \times 32^\circ$$

If T_K and T_F are equal then we get,

$$4T_K = 9 \times 273.15^\circ - 5 \times 32^\circ$$

$$T_K = 574.59^\circ$$

Question: What is the temperature in Celsius if the temperature of a healthy body is 98.4°F ?

Answer: The relation between Celsius and Fahrenheit temperature is

$$T_C = \frac{5}{9}(T_F - 32^\circ)$$

If $T_F = 98.4^\circ$, we get

$$T_C = \frac{5}{9}(98.4^\circ - 32^\circ) = 36.89^\circ$$

(i.e., it is nearly equal to 37°C)

Question: At which temperature the readings in Celsius and Kelvin scale are equal?

Answer: Never.

6.3 Thermal Expansion of Matter

6.3.1 Expansion of Solids:

Volume of almost all objects increases to some extent if they are heated. It is not difficult to understand the cause of heat and temperature if we explain them with the help of an atomic model. We can imagine a solid as a collection of many molecules. We can compare the molecular forces among them with a spring. We have imagined a spring among molecules to show how molecules are arranged in a solid as shown in figure 6.03. When the solid is heated, its molecules will vibrate. The higher the temperature, the more the molecules will vibrate. We have to improve this spring model to some extent to explain the real nature of

solids. We have seen in case of a spring that the force by which it is pulled when it is expanded to a certain distance, it pushes by the same force when it is compressed by the same amount. This is not true completely for the molecules of a solid. The amount of force by which molecules pull each other when they are moved away to a certain distance they push themselves by much more force when they are brought close to each other by the same distance. That is, this spring is a special type of spring. Less force is applied to expand but more force is applied to compress it.

Now imagine that the molecules are vibrating due to a certain temperature. For being a special type of spring during vibrations molecules do not come very near but can move further away. Now if the solid is heated more and the molecules will vibrate much more. Already you have understood that since the molecules cannot come very close due to this special type of spring but can go very far easily, so all molecules will establish a new equilibrium to move

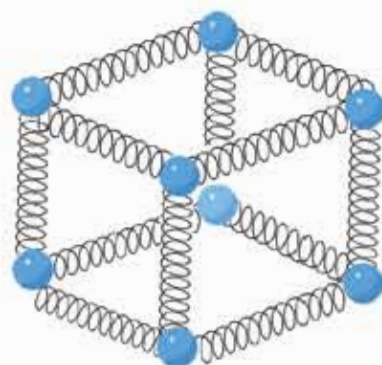

Figure 6.03: The molecules are connected with each other by a imaginary spring.

away slightly from one another. When all molecules will move away from one another, the whole solid seems to be expanded slightly.

Length, breadth and height of a solid are expand equally in three directions by the application of heat. To analyze this expansion three quantities named co-efficient of linear expansion, co-efficient of area expansion and co-efficient of volume have been introduced.

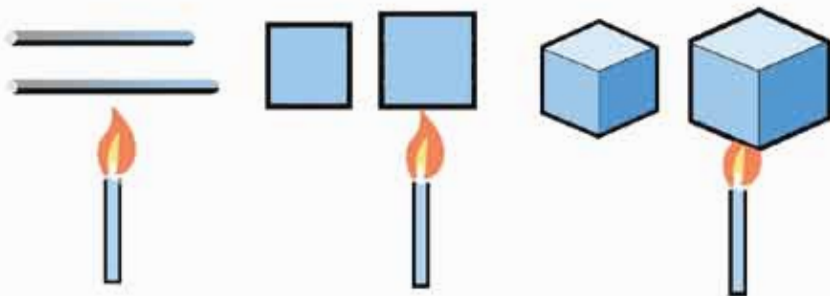

Figure 6.04: Length, cross section and volume of a solid are increased by heating.

If the length of an object is L_1 at temperature T_1 and the length is increased to L_2 after increasing the temperature to T_2 , then the co-efficient of linear expansion α is

$$\alpha = \frac{(L_2 - L_1)/L_1}{T_2 - T_1}$$

so,

$$L_2 = L_1 + \alpha L_1(T_2 - T_1)$$

Similarly if the area of an object is A_1 at temperature T_1 and increasing the temperature T_2 if the area is increased to A_2 , then the co-efficient of area expansion β is

$$\beta = \frac{(A_2 - A_1)/A_1}{T_2 - T_1}$$

so,

$$A_2 = A_1 + \beta A_1(T_2 - T_1)$$

Again similarly if the volume is V_1 at temperature T_1 and if the volume is increased to V_2 , then the co-efficient of expansion of volume is γ

$$\gamma = \frac{(V_2 - V_1)/V_1}{T_2 - T_1}$$

so,

$$V_2 = V_1 + \gamma V_1(T_2 - T_1)$$

You see that the unit of three quantities α , β and γ is K^{-1} .

$$\text{Dimension}[\alpha] = [\beta] = [\gamma] = T^{-1}$$



Example

Question: The length of a steel rod is 10m at 20 °C. If its length becomes 10.0167 m at 120 °C, then determine the co-efficient of linear expansion of steel

Answer:

Co-efficient of linear expansion,

$$\alpha = \frac{L_2 - L_1}{L_1(T_2 - T_1)}$$

Here, $L_1 = 10 \text{ m}$

$$L_2 = 10.0167 \text{ m}$$

$$T_2 = 120^\circ \text{ C}$$

$$T_1 = 20^\circ \text{ C}$$

$$\alpha = \frac{10.0167\text{m} - 10\text{m}}{10\text{m}(120^\circ\text{C} - 20^\circ\text{C})} = 16.7 \times 10^{-6} \text{ }^\circ\text{C}^{-1}$$

You have seen from the above examples that actually the value of the coefficient of expansion of solids is very small. For this reason, the three different co-efficients α , β and γ were not necessary. For working we could explain the co-efficient of linear expansion only. For example let us assume the matter of area expansion.

We see:

$$A_2 = A_1 + \beta A_1(T_2 - T_1)$$

But area A_1 is the product of length and width and if we consider the area of a square whose length is L_1 , then its area, after increasing the temperature, will be

$$A_2 = L_2^2 = [L_1 + \alpha L_1(T_2 - T_1)]^2$$

$$\text{Or } A_2 = L_1^2 + 2\alpha L_1^2(T_2 - T_1) + \alpha^2 L_1^2(T_2 - T_1)^2$$

$$\text{But } A_1 = L_1^2$$

$$\text{So, } A_2 = A_1 + 2\alpha A_1(T_2 - T_1) + \alpha^2 A_1(T_2 - T_1)^2$$

We have seen that the value of α is very small, so the value of α^2 is smaller. In fact it is so small that if we avoid the whole part with α^2 , then no problem will arise in our analysis or calculation. So we can write:

$$A_2 = A_1 + 2\alpha A_1(T_2 - T_1)$$

But we know,

$$A_2 = A_1 + \beta A_1(T_2 - T_1)$$

Certainly we can write:

$$\beta = 2\alpha$$

Similarly we can assume a cube of L length, width and height. Its volume at temperature T_1 is V_1 and the volume becomes V_2 after increasing the temperature to T_2 , so we have

$$V_2 = [L_1 + \alpha L_1(T_2 - T_1)]^3$$

According to the same argument, also here if we avoid the parts with α^2 and α^3 , then no problem will arise in our analysis or calculation. So only the first two terms will be present, i.e.

$$V_2 = L_1^3 + 3\alpha L_1^3(T_2 - T_1) \dots$$

But we know

$$V_1 = L_1^3$$

That is ,

$$V_2 = V_1 + 3\alpha V_1(T_2 - T_1)$$

So,

$$V_2 = V_1 + \gamma V_1(T_2 - T_1)$$

Certainly we can write

$$\gamma = 3\alpha$$

In our practical life we have to keep in mind the issue of expansion of solids. You have seen the gap between the rails of rail tracks. This has been done taking thermal expansion into consideration. If no space was left for expansion, the rail lines would bend. Cavities develop in teeth due to lack of regular brushing. The dentist fills these cavities with a special type of substance. The co-efficient of expansion of the substance has been made very carefully which is equal to that of the teeth. If the co-efficient of expansion were less than that of teeth, it would come out from the cavity while eating something hot! Again, if the co-efficient of expansion of the substance were greater, it would come out from the cavity of the tooth while eating something cold! Many of the general people know the matter of thermal expansion without studying physics. You will notice that when the cork of a bottle is stuck, hot water is poured on it so that the cork becomes loose after expansion of the bottle.



Example

Question: Why does a glass crack when hot water is poured in it?

Answer: More expansion occurs at different parts of glass when temperature is increased suddenly, this is why the glass cracks.

Question: The density of gold is 19.30 gm/cc and co-efficient of linear expansion is $14 \times 10^{-6} \text{ } ^\circ\text{C}^{-1}$. What will be the density when the temperature is increased to $100 \text{ } ^\circ\text{C}$?

Answer:

Density,

$$\rho = \frac{m}{V}$$

Here, V is volume and m is mass. Though the mass remains the same, the volume increases when temperature is increased. So, if the temperature is increased to $100 \text{ } ^\circ\text{C}$, the volume will be :

$$\begin{aligned}
 V' &= V + \gamma V(T_2 - T_1) = V(1 + 3\alpha \times 100) \\
 \alpha &= 14 \times 10^{-6} \text{ } ^\circ\text{C}^{-1} \\
 V' &= V(1 + 4.2 \times 10^{-3}) \\
 \rho' &= \frac{m}{V'} = \frac{m}{V(1 + 4.2 \times 10^{-3})} = \frac{m}{V} \times 0.9958 = 0.9958\rho \\
 \rho' &= 0.9958 \times 19.30 \text{ gm/cc} = 19.22 \text{ gm/cc}
 \end{aligned}$$

Question: What will be the density if the temperature is increased $1000 \text{ } ^\circ\text{C}$ more?

Answer: As the melting point of gold is $1064 \text{ } ^\circ\text{C}$, gold will melt.

6.3.2. Expansion of liquid

Liquids have no length or area. Liquids have only volume. So the expansion of a liquid means its volume expansion. While measuring the expansion of a liquid, we have to be alert, because a liquid is kept in a container. To measure the co-efficient of expansion when the liquid is heated, the container which is also

heated needs to be considered. So the expansion of a liquid in a container observed is not real expansion, it is an apparent expansion. Therefore, to measure the real expansion, the expansion of the container must be kept in mind always. Usually, the expansion of liquids is more than that of liquids. If it was not the case we could not see the apparent expansion. It seems to be apparent compression!

The most common example of the expansion of liquid is a thermometer. There are many types of thermometers, among them perhaps the clinical thermometer (Figure 6.05) is the most familiar.

A glass tube contains mercury at the bottom. If heat is applied, the volume of mercury is increased and it goes up through the capillary tube. To what extent it reaches is the measurement of the temperature. While measuring the fever by a thermometer, it is to be taken out from the mouth or the armpit, a very fine curve is made at the bottom of the narrow tube. Due to expansion, once the mercury level rises up, it cannot come down even after decreasing the temperature. Mercury is brought down by shaking.

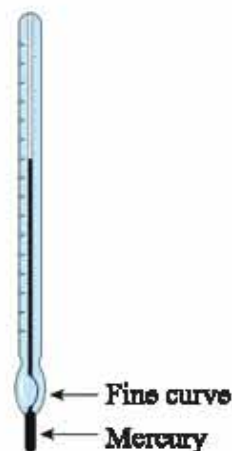

Figure 6.05 : Fine curve is made in tube, so that mercury can not fall in fever measuring thermometer.

Real and Apparent Expansion

It has been said earlier that a liquid is always heated in a container. If heat is applied, the expansion of the container occurs along with the liquid. So the expansion of a container is kept in mind to measure the exact expansion of a liquid. The expansion of a liquid, without considering the expansion of the container, is called apparent expansion. If the expansion of a liquid is measured considering the expansion of the container, it is called real expansion.

If a glass bulb with a long graduated stem is heated liquid with filled up to mark *A*, first we observe that the upper level of the liquid comes down to mark *B* (figure 6.06). It will happen because due to the application of heat the temperature of the bulb will increase before increasing the temperature of the

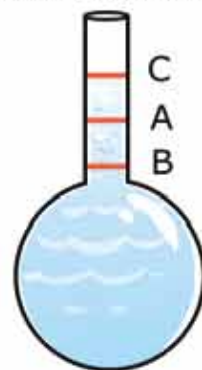

Figure 6.06 : Real and apparent expansion.

liquid, i.e., the bulb will expand a little bit.

After that if we continue applying heat, the height of the liquid will increase. As the expansion of liquids is more than solids, we will observe that finally the level of the liquid has reached mark C from B after passing the mark A.

If we multiply the height AB by the cross section of the tube, we will get the expansion V_B of the bulb. Again if we multiply the height B_C by the cross section, we will get the real expansion V_L of the liquid. Here the apparent expansion V_a is

$$V_a = V_L - V_B$$

6.3.3 Expansion of Gases

A solid has both shape and volume, so no problem arises in understanding the expansion of the solid. Though a liquid has no definite shape, it has a definite volume. So, we can explain or measure its expansion. It is very interesting in the

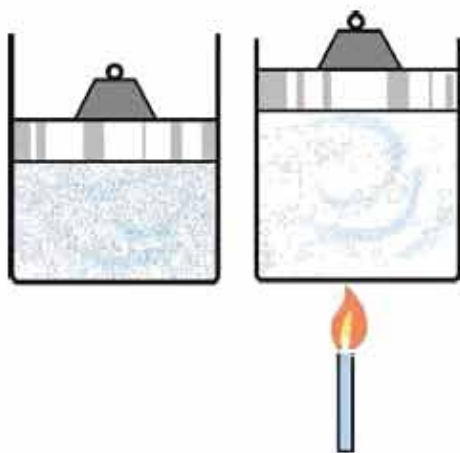

Figure 6.07 : The volume of air is increased by applying heat.

case of gas. Because neither does it have a definite shape nor a definite volume. A gas takes the whole volume of its container. If the same amount of a gas is kept in containers of different volumes, the pressures of the gases will be different. So, we can see that the increase of volume of a gas will be measured without changing its pressure as shown in the figure 6.07. An object of definite weight is placed on the piston of a cylinder so that it always applies equal pressure to the gas contained in the cylinder.

By applying pressure, liquids or solids cannot be compressed very much. But a gas can be compressed very easily. Therefore, at first we have to know the relation between the pressure and volume of a gas. It is called the ideal gas

equation and it is:

$$PV = nRT$$

Here P is pressure, V is volume, n is the amount of gas (measured in mole), R is a constant ($8.314 \text{ JK}^{-1} \text{ mol}^{-1}$) and T is temperature in Kelvin scale.

Now we can find out the co-efficient of expansion of a gas. At a certain pressure if the volume of a gas is V_1 at temperature T_1 and the volume is V_2 at temperature T_2 the co-efficient of volume expansion β_p of the gas will be:

$$\beta_p = \frac{(V_2 - V_1)/V_1}{T_2 - T_1}$$

We know,

$$PV_1 = nRT_1$$

$$PV_2 = nRT_2$$

Hence

$$P(V_2 - V_1) = nR(T_2 - T_1)$$

Dividing the left side by PV_1 and the right side by nRT_1 we get:

$$\frac{V_2 - V_1}{V_1} = \frac{T_2 - T_1}{T_1}$$

So,

$$\frac{(V_2 - V_1)/V_1}{T_2 - T_1} = \frac{1}{T_1}$$

That is,

$$\beta_p = \frac{1}{T_1}$$

Therefore, you can see that the co-efficients of expansion of gases are not constants at all. It is reciprocal to the temperature (T_1^{-1}), i.e., the less the temperature is the more the expansion of solid will be! In other words, at a definite pressure and a definite temperature the amount of expansion due to increase of temperature by one degree is less than the expansion due to increase of temperature by one degree at the same pressure but at low temperature.



Do Yourself

Take two balloons, put a small amount of water into one of them and air of the same volume in another one. Now put the two balloons under hot water for a small interval of time. You will notice that the balloon containing water remains the same, because the expansion of liquid due to heat is smaller but the balloons containing air has expanded in volume to a large extent, because the expansion of gas is much more higher than that of liquid.

6.4 Effect of Temperature on Change of State

Already you have know that all solids consist of molecules and in solids molecules attract one another from a certain position. If heat is applied, their vibrations increase and the molecular bonds become weak. They start to move rolling upon one another and we call it a liquid. If the temperature is increased further, the molecules start to move freely. We called it a gas. Now we observe this more deeply and we will be introduced to different quantities which are related to the change of state of matter.

When heat is applied to a solid, its temperature goes up. (we will know later at what rate the temperature will rise and on what factor it depends.)

If the temperature (at a definite pressure) reaches a definite value, the solid starts to melt. This process is called fusion and the temperature at which the fusion starts is called the melting point. If we continue to measure the temperature, surprisingly we will notice that when fusion has started, the temperature of the mixture of some amount of solid and some amount of liquid does not increase any more even if heat is applied (as shown in the figure 6.08). During this time the heat is used to loosen the intermolecular bonds of the molecules in the solid. So, the temperature cannot rise because applied heat cannot make the molecules move further. During fusion at a definite melting point the amount of heat which is used to convert the whole solid into liquid, is called the Latent Heat of Fusion.

On the solid being totally liquefied the temperature starts to increase again (as shown in the figure 6.08). The temperature increases gradually and at one stage the liquid starts to convert into gas. This process is called vaporization and the temperature at which vaporization occurs is called the boiling point. Again, everyone is being reminded that this boiling point depends upon pressure.

When the process of vaporization starts by absorbing the heat energy, the molecules of the liquid start to become free from the molecular bonds among themselves. Here also the temperature does not increase like fusion even if heat is applied. During vaporization of liquid the amount of heat by which the whole liquid is converted into a gas, that heat is called Latent Heat of Vaporization.

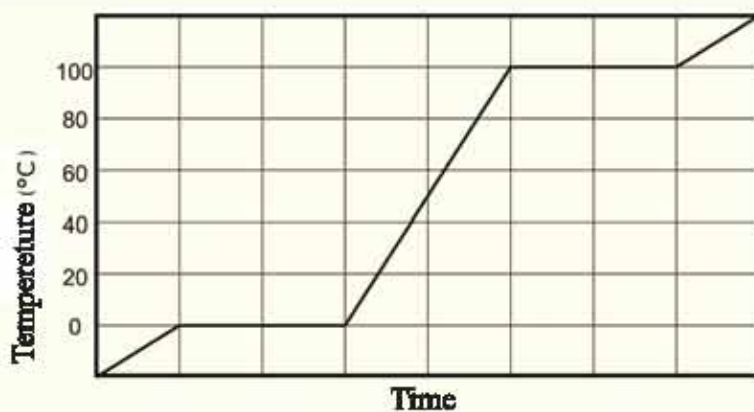

Figure 6.08 : Melting and boiling point does not change during heat.

After converting the whole liquid into a gas the temperature of the gas continues to increase if heat is being applied. If the temperature is raised to extremely high levels, the molecules will become ionized and a fourth state of matter called plasma will start to form but this is something different.

All of us have seen at least one example of the process by which solids can be converted into liquids and liquids into gases, that one is ice converted into water and water into vapour. Although we do not see directly the latent heat of fusion or latent heat of vaporization, but we have felt its effect. When we suddenly come to an open place or in open air from a crowded or a closed place, then our sweating body becomes cool. This is because during the vaporization of sweat, the required latent heat of vaporization is absorbed from our body and our body becomes cool. By applying heat solids can be converted into liquids and liquids into gases, its reverse process also occurs. By extracting heat gas can be

converted into liquids and liquids into solids. The process of converting a gaseous substance from gaseous state to the liquid state is called liquification. The process of converting a liquid substance from its liquid state to solid state is called solidification.

During the change of state of matter, the transformation from solid to liquid and from liquid to solid happens at a particular temperature. But without reaching that particular temperature a substance can transform from solid to liquid, liquid to gas or directly from solid to gas. It is not difficult to understand this if we go back to the molecular model of a substance. If a molecule somehow gets sufficient energy and due to this, its kinetic energy is increased sufficiently then the molecule may come out from the surface of solid or liquid substance. Since a large number of molecules from air are continuously striking the surface of solid or liquid, so sometimes some of the molecules of solids or liquids may obtain the required energy to become free. The more the surface area is, the faster the process will be. All of us have seen this process e.g., a wet object dries by itself. For this the temperature does not need to be at the boiling point. Drying means the evaporation of the molecules of a liquid. This may happen at any temperature and the process is called evaporation.

At the time of evaporation, water absorbs the latent heat of vaporization; the reverse process is also true. If vapors transform into water by any process then it delivers heat. During a cyclone the air filled with water vapour goes upwards, when the vapor transforms into water the latent heat of vaporization is released as energy. This energy acts as the source of the devastating energy of a cyclone.

Dependence of Vaporization

You have seen that wet clothes do not dry easily in the rainy season. On the other hand in winter the clothes become dry naturally when they are kept inside the house. After washing the clothes should be spread well for drying. If the wet clothes are kept folded, they remain wet. The matter of drying of wet clothes is nothing but the evaporation of water. So, you notice that the evaporation of water depends on some factors. To speak the truth, what is true for water is also true for other liquids. Therefore, we can make a list of the factors on which the evaporation of liquids depends:

Flow of air: The rate of vaporization increases if the air flows faster over the liquid.

The area of the exposed surface of the liquid: Evaporation increases as the area of the exposed surface of the liquid increases. A glass of water takes quite

some time to evaporate but the same amount of water poured into a plate evaporate much faster.

Nature of liquid: The less the boiling point of a liquid, the higher would be the rate of evaporation. The rate of evaporation of volatile liquids is a maximum.

Pressure of air: The lower the pressure of air, the more the rate of evaporation. The rate of evaporation in vacuum is a maximum, so air is taken out to make dry food with a pump for preservation of the food.

Temperature: If the temperature of the air in contact with the liquid increases, the rate of evaporation will increase.

Dryness of air: The drier the air over the liquid surface is, the more the liquid evaporates.

6.5 Specific Heat

Heat, temperature and the relation between them are discussed so far, however the amount of heat needed to increase the temperature of an object has not been discussed yet. You might have noticed that in order to heat some water, it needs to be kept on the oven for a long time, but approximately the same amount of metal take little time to be heated at the same temperature. This is because, the specific heat of a metal is much less compared to water. The amount of heat required to increase the temperature of a body of mass 1 kg by 1 K is called the specific heat. That is, if an amount of heat Q is required to increase the temperature from T_1 to T_2 , the specific heat will be:

$$s = \frac{Q}{m(T_2 - T_1)}$$

The unit of specific heat- $\text{J kg}^{-1}\text{K}^{-1}$

Heat capacity C is the amount of heat required to increase the temperature 1K of a body. The amount of heat required to increase the temperature 1K of a body of mass 1 kg is called specific heat. So we can easily find out the heat capacity C of a body if we know the specific heat of that substance. If the mass of an body is m and the specific heat is s , then the heat capacity will be:

$$C = ms$$

The heat capacity of 10 kg gold is

$$C = 10 \times 230 \text{ JK}^{-1} = 2300 \text{ JK}^{-1}$$

In comparison the heat capacity of 10 kg water is

$$C = 10 \times 4200 \text{ JK}^{-1} = 42,000 \text{ JK}^{-1} \quad \text{i.e. about 20 times more.}$$

This means that gold or any other metal can be heated quickly but water cannot be heated so easily.

6.6 Fundamental Principles of Calorimetry

In winter during a bath we often pour a little boiling water into a bucket of cold water. The boiling water slowly become cold by giving up heat to the cold water. The cold water of the bucket also slowly becomes hot by absorbing the heat from the boiling water. Within a short time, all the water will get to a comfortable temperature by decreasing the temperature of the boiling water and increasing the temperature of the cold water. If we wish, we can find things like the amount of heat lost or gained, and their final temperature when various objects of various temperature are mixed together. To do so we just have to know a few rules. They are:

- (1) The body at higher temperature gives heat to the body at the lower temperature until they reach thermal equilibrium.
- (2) The amount of heat given up by the bodies at higher temperature will be equal to the heat gained by the bodies at the lower temperature. (We assume that no heat is lost in this process by any other means.)



Example

Question: A piece of ice of mass 100 gm is dropped into water of 1 liter at temperature 30 °C. What will be the temperature of the water after melting the whole piece of ice?

(Latent heat of ice $L=334 \text{ kJ/kg}$)

Answer: Let us assume the temperature of ice is 0°C .

Mass of ice $m_1 = 100\text{ gm} = 0.1\text{ kg}$

Mass of 1 liter water $m_2 = 1\text{ kg}$

Specific heat of water $s = 4.2 \times 10^3\text{ Jkg}^{-1}\text{K}^{-1}$

The water of 1kg has to supply the heat that is required to melt the piece of ice and to raise the temperature of the ice melted water to its final temperature. Let us consider the final temperature of water is T , then the amount of heat absorbed by the ice is:

Heat required to melt: m_1L

The heat required to increase the temperature from 0°C to T after melting: $m_1s(T-0)$

The mass of water m_2 supplies these amounts of heat, so its temperature will decrease.

That is,

$$\text{The heat supplied: } m_2s(30^\circ\text{C} - T)$$

These two types of heat must be equal. Hence:

$$m_1L + m_1sT = m_2s(30^\circ\text{C} - T)$$

$$T = \frac{30^\circ\text{C} \times m_2s - m_1L}{(m_1 + m_2)s}$$

$$T = \frac{30 \times 1 \times 4.2 \times 10^3 - 0.1 \times 334 \times 10^3}{(1 + 0.1)4.2 \times 10^3} = 20^\circ\text{C}$$

Question: What is the final temperature if 1 liter of water temperature 20°C is added to 2 liter water at temperature 75°C ?

Answer: Let us consider the final temperature is T , so the temperature of 2 liter of water reaches T by decreasing the temperature from 75°C . Absorbing this amount of heat the temperature of 2 liter water reaches T by increasing the temperature from 20°C .

Hence

Mass of 1 liter water $m_1 = 1\text{ kg}$

Mass of 2 liter water $m_2 = 2\text{ kg}$

Specific heat of water $s = 4.2 \times 10^3\text{ Jkg}^{-1}\text{K}^{-1}$

$$m_1s(75^\circ \text{ C} - T) = m_2s(T - 20^\circ \text{ C})$$

$$T = \frac{(75m_1 + 20m_2)s}{(m_1 + m_2)s}^\circ\text{C} = \frac{75 \times 2 + 20}{2 + 1}^\circ\text{C} = 56.6^\circ \text{ C}$$

Question : A piece of iron of mass 10 gm heated at temperature 120° C is dropped into a container of water of mass 1 kg at temperature 30° C . What will be the temperature of water?

Answer:

Mass of iron $m_1 = 0.01 \text{ kg}$

Mass of water $m_2 = 1 \text{ kg}$

Specific heat of iron $s_1 = 0.45 \times 10^3 \text{ Jkg}^{-1}\text{K}^{-1}$

Specific heat of water $s_2 = 4.2 \times 10^3 \text{ Jkg}^{-1}\text{K}^{-1}$

The amount of heat given up by the piece of iron is equal to the heat gained by the water. So, the temperature of iron T will be

$$m_1s_1(120^\circ \text{ C} - T) = m_2s_2(T - 30^\circ \text{ C})$$

$$T = \frac{120m_1s_1 + 30m_2s_2}{m_1s_1 + m_2s_2} = \frac{120 \times 0.01 \times 0.45 \times 10^3 + 30 \times 1 \times 4.2 \times 10^3}{0.01 \times 0.45 \times 10^3 + 1 \times 4.2 \times 10^3}^\circ\text{C}$$

$$T = 30.1^\circ \text{ C}$$

6.7 Effect of Pressure on Melting Point and Boiling Point

If pressure is applied on a substance, its melting point goes down, for this reason when pressure is applied, two pieces of ice unite together to form a single piece.

Where pressure is applied on an ice, the melting point decreases there and the ice melts, after the removal of pressure the melting point again goes back to the previous value. As a result the water obtained from the fusion of ice again freezes into ice. Attaching two masses to the ends of a string, if it is placed upon the surface of an ice bar so that the masses are hanging at the two ends; it will seem that the string has cut the ice bar into two pieces. But examining the ice we will see that the ice is still a single piece (Figure 6.09).

Boiling point changes due to pressure. Boiling point decreases if pressure is low, boiling point increases if pressure is high. This is why those who go to big heights while mountain climbing, they have to cook something for a long time because due to low pressure water starts to boil at comparatively low temperatures. As temperature can not be increased, so it takes a longer time to cook. Pressure cookers have been made for this reason. During cooking pressure is increased by confining the vapors inside and for this reason, the boiling point of water is increased so water continues to boil at a high temperature. As the temperature is high, cooking will be done faster.



Figure 6.09: It is possible to cut a ice bar by pressing with a fine wire.

If pressure is applied, the melting point of a gas increases. So without too much cooling, a gas can be liquefied by increasing pressure. Then a lot of heat is produced, which has to be taken out properly.



Exercise



General questions

1. When a pot of mercury is heated, the height of mercury decreases first then increases. Why?
2. Does temperature exist in space where there are no atoms or molecules?
3. Why do we feel cold when we come from a hot, humid and crowded place to an open area?
4. Why do the drops of water condense on the surface of a glass when a piece of ice is kept in the glass of water?
5. Why is cooking done faster in a pressure cooker?



Mathematical questions

1. Scientist Celsius introduced a thermometer in which the boiling point of ice was 100°C and the boiling point of water was 0°C ! At which temperature the readings in Celsius and Fahrenheit scales are equal?
2. At which temperature will the density of gold decrease to 0.001% ?
3. The temperature of water increased by 15°C after a piece of hot iron of mass 1 gm at temperature 30°C was put into water of 1 liter . What was the temperature of the piece of iron?
4. If 10 J heat is supplied per second to a piece of ice of 1 gm at temperature 0°C , how long it takes to vaporize the ice?
5. If the temperature of a gas confined in a closed cylinder is increased from 30°C to 100°C , by what percentage will the pressure of the gas be increased?



Multiple choice questions

Give tick (\checkmark) mark by the side of the correct answer.

1. At the time of construction of a rail line why are small gaps kept in between two rails?
 - (a) To save iron.
 - (b) In summer to increase or to decrease the temperature of the rail line.
 - (c) To produce knocking sound when the trains run.
 - (d) To avoid bending of the rails due to its thermal expansion.
2. Why do we feel comfort when wind is blown by fans over our sweating body?
 - (a) The wind blown by the fan prevents sweat to go out of the body.
 - (b) Evaporation produces cooling.
 - (c) The air blown by the fan bears cold water vapors.
 - (d) The air blown by the fan enters into our body through hair follicles.

3. With the help of latent heat —

- i. The temperature of a body increases.
- ii. The state of a substance changes.
- iii. The internal energy of a body increases.

Which one is correct?

- (a) i (b) ii (c) ii & iii (d) i, ii & iii

With the help of the figure answer the question no. 4 & 5

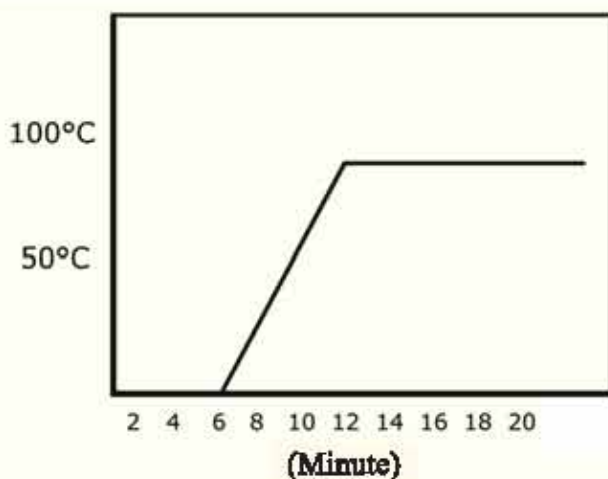

Figure 6.10 : Ice melting graph

4. How much time was required to melt all of the ice?

- a) 2 min b) 4 min
c) 6 min d) 8 min

3. What is the required time in minutes for the water to reach the boiling temperature?

- a) 6 b) 8
c) 12 d) 18

**Creative question**

- The distance between two electric poles is 30 m. A copper wire with a length of 30.001 m was connected to those two pillars on a day when the temperature was 30°C . The coefficient of linear expansion of copper is $1.67 \times 10^{-6}\text{K}^{-1}$. The wire snapped on a winter day when the temperature of the air was 4°C .
 - Define triple point of water.
 - If two bodies have equal amounts of heat, can they be at different temperatures? Explain.
 - Express the temperature of air in Fahrenheit scale.
 - Explain the cause for the wire to snap with mathematical logic.
- The length of two metal rods is 6 m. If one rod is heated to increase its temperature from 30°C to 80°C , its length becomes 6.0051 m after extension. If another rod is heated to increase its temperature from 20°C to 60°C , its length becomes 6.0041 m after extension. The co-efficient of linear expansion is α , the co-efficient of area expansion is β and the co-efficient of volume expansion is γ .
 - The exchange of heat between two objects depends on which factors?
 - Write down why temperature and heat are different?
 - If the temperature of a metal rod is 80°C , what is it in the Kelvin scale?
 - Make comments about the material of the two rods with a mathematical explanation.

Chapter Seven

Waves and Sound



To understand physics perfectly we need have a clear idea about some topics, one of them is wave. In this chapter we shall limit our discussions to several types of mechanical waves which are known to us.

Sound is one kind of a wave. In our daily lives, sound plays a very important role, so we shall discuss sound, velocity of sound, echo and sound pollution in this chapter.



By the end of this chapter we will be able to-

- explain the characteristics of waves.
- set and measure the simple mathematical relations among the quantities related to waves.
- explain the characteristics of sound waves.
- explain creation of an echo.
- explain the uses of echo in our daily lives.
- set up the mathematical relation among the velocity of sound, frequency, and wavelength and measure these quantities.
- explain the change of velocity of sound.
- explain the range of hearing and its uses.
- explain the pitch and intensity of sound.
- explain the reasons and consequences of sound pollution and the techniques to prevent it.

7.1 Simple Harmonic Motion

By attaching a mass at the lower end of a spring if we release it after pulling, it will move up-down (In chapter 3 and 4 we have explained this motion). We have seen that due to friction or other means, energy is lost; and it stops after a while. Otherwise, it would move up-down for an infinite time. We have also seen that in simple harmonic motion, the energy of the mass attached to the spring exchanges between kinetic energy and potential energy. This occurs since the spring obeys Hooke's law. The Hooke's law states, if the spring constant is k , mass is m and position is x , then the applied force on it,

$$F = -kx$$

The harmonic or oscillatory motion that obeys Hooke's law is called simple harmonic motion. This is one of the most important motions in physics.

$$T = 2\pi\sqrt{\frac{m}{k}}$$

In your book, there is no scope of deducing it, but there is no harm in knowing it.

If the spring constant of a spring is k and m is the attached mass, then the time period of the mass is,

$$T = 2\pi\sqrt{\frac{l}{g}}$$

If instead of being a spring, it would be a pendulum hanging from a string and if the length of the string is l and gravitational acceleration is g , then the time period is:

$$T = 2\pi\sqrt{\frac{l}{g}}$$

(No, there is no mistake, whether you hang a light mass or a heavy mass, the time period will be the same, it does not depend on the mass.)



Example

Question : Hang a stone of mass 10 gm from a string 1 m long. What is its time period?

Answer:

$$T = 2\pi \sqrt{\frac{l}{g}} = 2\pi \sqrt{\frac{1}{9.8}} \text{ s} = 2.0 \text{ s}$$

The time period remains the same whether the mass of the stone is 10 gm or not. If you wish, by measuring the time period you can determine the value of g just now. Try and see!

If a mass is attached to the lower end of a spring, the mass will extend the spring and. This extended length of the spring is called the equilibrium condition (Figure 7.01-0).

Now we pull the mass downward by a short distance a and release it (Figure 7.01). Then the mass will moving upward, crossing the equilibrium condition, it will move upward by a distance a . Then again it will be moving downward, crossing the equilibrium condition, it will come down and this will continue.

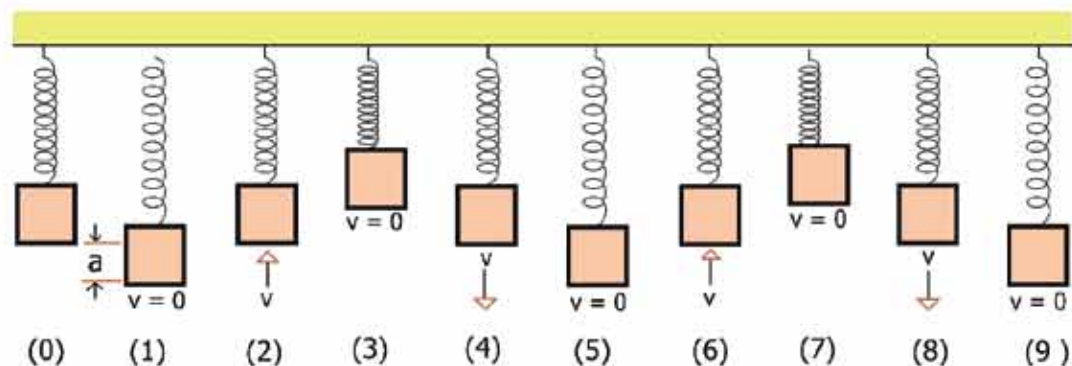

Figure 7.01: (0) is equilibrium condition. After pulling at position (1), the spring is oscillating in simple harmonic motion when it is released.

When the mass completes the positions $2 \rightarrow 3 \rightarrow 4 \rightarrow 5$ and comes to the position (6) in the same way (moving upward with velocity v) from where it started, then we say a complete oscillation has taken place. It has to be remembered that completing $2 \rightarrow 3$ positions when the mass comes to the position 4, it will come to the position from where it started, but it is not a complete oscillation. Because at the first 2 position the mass moves upwards and at the next 4 position it is moving downwards, therefore it did not come to the same or initial position in the same manner.

To analyze the simple harmonic motion, it is better to explain some quantities. The first may be the time period T . The time required for one complete oscillation is called the time period. Frequency f is the number of complete oscillations per second. Therefore, $f = \frac{1}{T}$. If time period is expressed in second, then unit of f will be Hertz (Hz).

In simple harmonic motion, amplitude is the maximum upward (or downward) distance. As shown in figure 7.01, here the amplitude is a .

The next term is phase. When the mass attached to the spring is moving up and down, if we follow the mass at any instant, we will see that it will stay in a certain position from the equilibrium; this position is its phase. In simple harmonic motion this definite condition of the mass and the spring will return identically just after one time period. In terms of physics, we can say in simple harmonic motion the phase that develops at any instant, after one time period, this phase returns again.

7.2 Waves

All of us have seen waves, when a stone is thrown into water then waves spread out in all directions from that point. When a bulb is switched on in the room, the light that spreads in the room is also a wave. When we talk, the sound that reach from one place to another place is also a wave. When a compressed spring is released, the deformation that propagates through it is a kind of a wave too. In short, we can say, we can realize what a wave is. But what will we say if we want to give a nice definition for it in terms of physics?

To keep it simple, wave is a process of transferring energy from one place to another through a medium, where the particles of the medium can oscillate about their position but are not displaced permanently from there.

Now we can verify whether our definition of wave matches with our experience or not. When a launch moves through the middle of a river, the waves that it creates hit the bank of the river. Therefore, surely we can say energy is transferred from one place to another. If we look at floating water hyacinth we

will see that when the wave is propagating, at that instant the water hyacinth is moving up and down and after the wave has passed it becomes stationary as before. The water hyacinth does not come to the bank with the waves at all.

You have now understood the relation between the simple harmonic motion and the wave. If we look at a particular point of a medium, then this point executes simple harmonic motion when the wave propagates through this point. In the case of the water hyacinth this occurs, so far as the water wave propagates through it, up to this time simple harmonic motion was present there. There is no wave in the simple harmonic motion of a point, but every point of the wave is executing individual simple harmonic motion.

Therefore, the definition we have given for wave is correct. But we have to remember that there are many types of waves, for which this definition may not be perfectly correct. For propagation of wave we talked about a medium, but when light reaches the earth from the sun, there is no need for a medium then. Light is an electromagnetic wave. We will discuss this in chapter nine. The scientists are talking about a new type of wave called gravity wave, which they have observed, very recently, for the first time. It also does not need any medium. In quantum mechanics, an amazing branch of physics, deals with another type of wave known as wave function which is even more spectacular; there the wave cannot be seen directly, only its effect can be experienced.

Therefore, for the time being we will limit our discussions only to those waves which requires mediums like solids, liquids or gases. The name of this type of wave is mechanical wave.

7.2.1 Characteristics of Waves

While discussing waves, several types of characteristics arise. Here, we will discuss all the characteristics of waves, specially the mechanical waves.

- (i) For mechanical waves a medium is necessary. Waves can be created in water, a wave can be transmitted in a spring, a wave can be created in a rope. The sound we hear is also a wave and its medium is air.
- (ii) When a wave propagates through a medium, the particles of the medium oscillate (vibrate or go up-down) about its own position but are not displaced permanently with the wave.

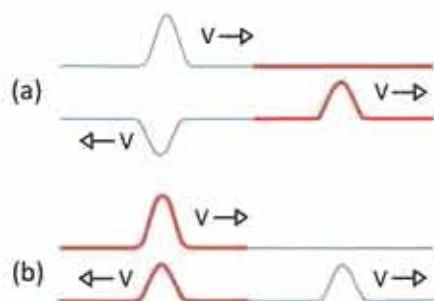

Figure 7.02: A wave is reflecting and refracting through a wire of different cross section. (a) When it travels from a thin wire to a thick wire one type of reflection occurs (b) When it travels from a thick wire to a narrow wire another type of reflection occurs

(v) Reflection or refraction occurs for waves, it is discussed elaborately for light, in the next chapter. At present you know that at the time of travelling from one medium to another medium, if part of a wave returns back to the first medium, it is called reflection (Figure 7.02). When a wave travels from the first medium to the second, it is refraction. When we hear an echo of sound, it is reflection. If we hear external sound when we are submerged under water it is due to refraction.

(vi) Among all the characteristics of waves, the most important is superposition, even though this is not observed often by our eyes in our daily lives. Let us consider that two waves coming from two different places reach one place. When one wave is trying to pull the medium up, another wave is then trying to pull it down, what happens then? These are the subjects of superposition, which will give you a deep insight into waves, and you will be able to understand it very clearly. At present,

(iii) Energy can be transferred from one place to another through waves. The more the energy, the more the amplitude of the wave. Energy is proportional to the amplitude of the wave. If the amplitude is doubled, energy is increased four times.

(iv) Every wave has a velocity; this velocity depends on the nature of the medium. In air, the velocity of sound is 330 m/s, in water this velocity is 1493 m/s ! The velocity of a wave in a tight rope (under tension) will be more than the velocity of the wave in a loose rope.

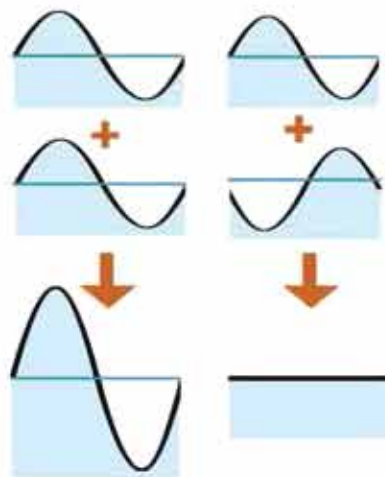

Figure 7.03: Addition of two waves can create a large wave, one can even cancel the other.

only two easy matters are shown in figure 7.03. The two waves, can reinforce one another or can destroy each other.



Do Yourself

Pour some water on a big plate in a bright place. Make sure that there is no vibration on the plate. If you touch any point of the water, the wave will spread around from that point and at the bottom of the plate you will see its shadow or reflections. Touching just the centre of the water of the plate, you will see a wave starting from the centre and spreading to the edge of the plate and again returning to the centre after reflection from there. If the wave can be created properly, meeting at the centre it will again spread around. If you try a little bit, you can measure the velocity of this wave. Try and see.

What will happen if you touch a little further from the centre? Try and see.

7.2.2 Types of Waves

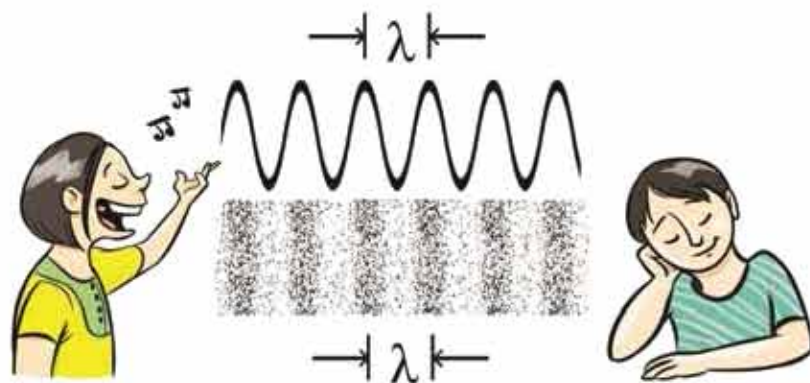
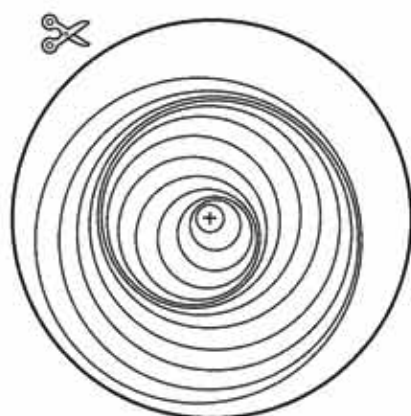
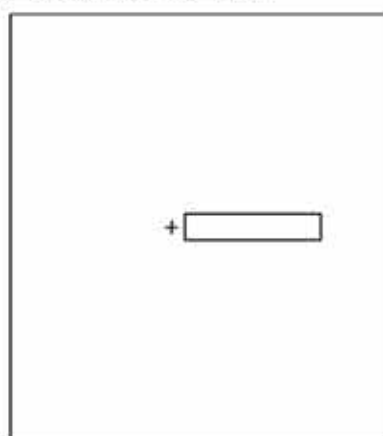

Figure 7.04: Sound is a longitudinal wave of compression and rarefaction created by the pressure in air. Here λ is the wavelength

When a wave propagates through a spring, the wave moves forward by contraction and expansion of the spring. Again by shaking one end of a rope a wave can be formed and can be sent through the rope. There is a fundamental difference between the two waves. The wave formed in the spring was of contraction and expansion, the direction of contraction and expansion of the spring and the direction of wave is the same. The name of this wave is longitudinal wave. Sound (Figure 7.04) is this type of a longitudinal wave.



1. Make a photocopy of this and cut it as a circle.



2. Make a void by cutting along the middle of the paper as shown in the above picture.

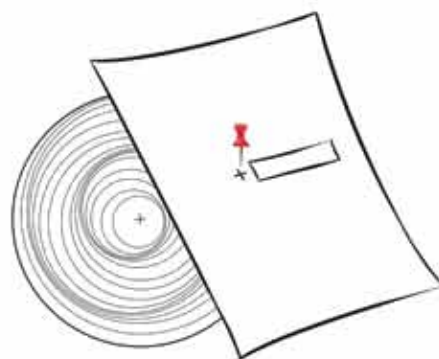

3. Now put the rectangular paper on the circular paper and enter a small pin through the cross mark (x)

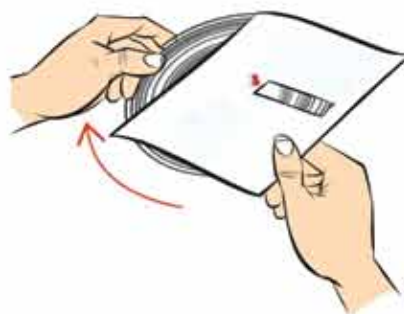

4. Now rotate the circular paper upwards as shown in the picture.

Figure 7.05: Model of how longitudinal wave advances.

When we produce a wave in the rope by shaking it, there the vibration of the rope does not take place along the direction of the velocity of the wave. The direction of vibration i.e. up and down of the rope, is perpendicular to the direction of the velocity of the wave. The name of this type of a wave is a transverse wave. The wave produced in water is an example.



Do Yourself

Make a photocopy of figure 7.05. Now cut it shown as in the figure. Observe that a small window is made on the rectangular paper below. Now put the rectangular paper on the circular paper. Now enter a small wire or pin through the cross (x) mark and fold the wire by pressing it. Now rotate the circular paper below and see through the cut portion, clearly you will see how longitudinal waves advance.

7.2.3 Wave related quantities

The quantities we have talked about in simple harmonic motion, actually all of them can be used in case of waves. In a wave complete oscillation occurs, it has a time period, frequency and amplitude. We have seen that when a wave propagates, if we look at a particular particle of a medium, we will see that the particle is executing simple harmonic oscillation!

In case of wave we can talk about two new quantities, one of them is the wavelength. Wavelength is the distance from any phase of the wave to the next identical phase (Figure 7.04). Therefore, the distance travelled by a wave in one time period is the wavelength.

In waves there is a second quantity which is not present in simple harmonic vibration, this is wave velocity. The distance travelled by a wave in one second is called the wave velocity. The number of time periods present in one second is the frequency, if the frequency is f and wavelength is λ , then the velocity can be expressed as,

$$v = f\lambda$$

When a wave travels from one medium to another medium, then change of its velocity occurs. Since the frequency always remains the same, so when a wave

travels from one medium to another then its wavelength changes. Therefore, when waves propagate through different medium, its velocity or wavelength changes, but frequency or time period never changes.



Example

Question: In figure 7.06 a wave is shown. Among the wave's amplitude, wavelength, time period, frequency and velocity which magnitude can be determined from the figure? Determine them.

Answer: From the information that is given in the figure, only amplitude (0.1 m) and wavelength (2 m) of the wave can be determined. It is not possible to determine time period, frequency or velocity from the information that are given in the figure! The wave shown above is the condition of the wave at a particular time. Here there is no information how the position changes with time.

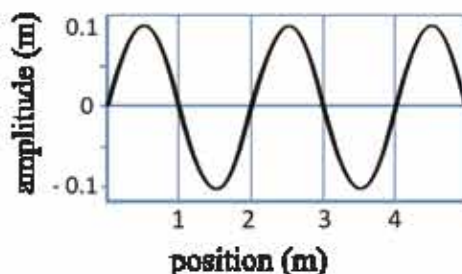

Figure 7.06 : A wave with respect to position

Question: In figure 7.07 another wave is shown. Among the wave's amplitude, wavelength, time period, frequency and velocity which magnitude can be determined from this figure? Determine them.

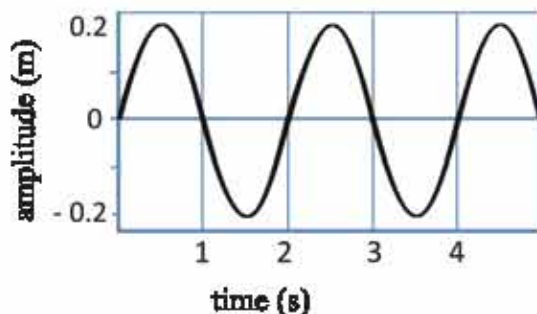

Figure 7.07: A wave with respect to time

The amplitude (0.2 m) and time period (2 s) of this wave can be determined; from this figure other information cannot be determined. How the wave changes with time at a particular position is shown in the figure. So, it is not possible to determine the wavelength.

Question: Figure 7.08 shows a wave at a particular time in different position and for a particular positions in different times. Determine its amplitude, wavelength, time period, frequency, and velocity.

Answer: From the first figure we see that, the wave has,

$$\text{Amplitude, } a = 0.1 \text{ m}$$

$$\text{Wavelength, } \lambda = 1 \text{ m}$$

From the second figure we see that, the wave has,

$$\text{Amplitude, } a = 0.1 \text{ m (we know it from the first figure also)}$$

$$\text{Time period, } T = 0.2 \text{ s}$$

We can calculate frequency f from the time period,

$$f = \frac{1}{T} = \frac{1}{0.2} = 5 \text{ Hz}$$

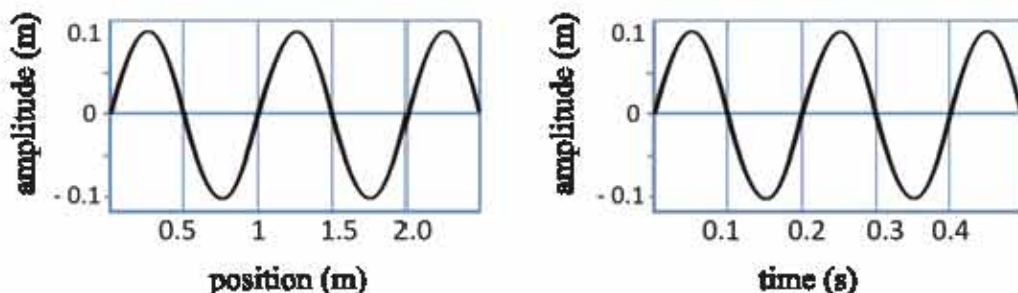

Figure 7.08: A wave with respect to position and time simultaneously

Therefore, using the information of the two figures, we can say

$$v = \lambda f = 1 \text{ m} \times 5 \text{ Hz} = 5 \text{ m/s}$$

Question: In figure 7.09 a wave is shown, at which positions are the phases equal.

Answer: At A and C, phases are equal.

At A and B, though the amplitudes are equal their phases are opposite.

At D and E, though they are equal, phases are not equal.

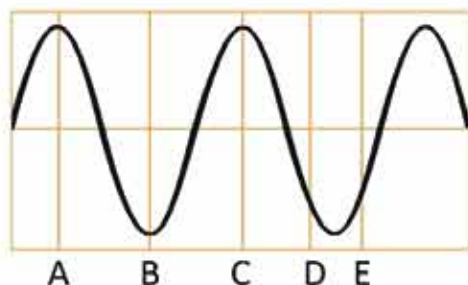

Figure 7.09: Phase of a wave at different position

7.3 Sound Wave

To produce sound waves a source is needed, a medium to send it through, and any type of receiver to receive that sound. There are many sources of sound around us. Obviously, the most familiar source is our throat; sound is created by the vibration of the vocal cord when air flows through it in our throat. We will feel the vibration if we touch our throat during conversation.

Certainly you have noticed that the voice of a male is deep and the voice of female and children is sharp. When we make a sound then air comes out through throat from our lungs. In our throat there is a wind pipe through which air enters the lungs and come out from the lungs. To produce sound larynx is situated upon it. There are two membranes which work as valves, called the vocal cords. These vibrate during the flow of air and produce sound. The vocal cords of males become stiff with the increasing of age, whereas for females it remains soft. This is why males produce sound of low frequency and females produce sound of high frequency. Due to this, the voice of males is deep and that of the females is high pitched.



Do Yourself

Cut a piece of paper as shown in Figure 7.10. Placing it between the two fingers, blow, keeping it on your mouth. The two pieces of paper will vibrate like vocal cords of the larynx and produce a sound. Cut the paper in different ways and try to produce different kinds of sounds.

Besides throat, sound can be produced by vibrating the thin diaphragm. When you hit your school bell it starts vibrating and sound is produced. If you grip the bell then the vibration will stop and the sound will stop instantly. After producing sound by vibration, we need a medium to transmit it from one place to another. Sound can also be sent through liquids

and solids but we are used to hearing sound using air as a medium. To show that sound cannot propagate without a medium, we keep a calling bell as shown in Figure 7.11 in the laboratory. The

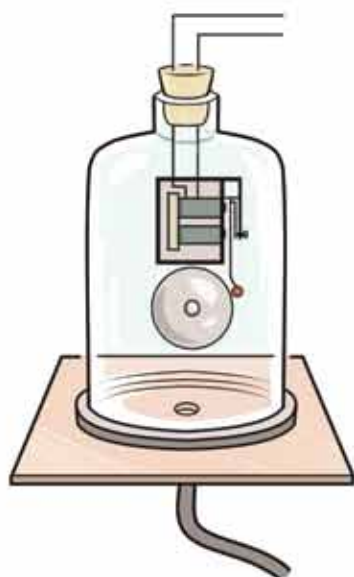

Figure 7.11: The sound of the calling bell will not be listen if it is evacuated gradually by a pump.



Figure 7.10: Sound can be produced by preparing vocal cord using paper and blowing it.

calling bell can be sounded by supplying electricity from outside. The sound of the calling bell will be slowly dulled if it is evacuated gradually by a pump. If the bell jar is completely emptied of air, though the bell will vibrate inside but it seems from outside that there is no sound.

We can hear sound with our ears. The sound that can be heard has frequency between 20 Hz to 20,000 Hz or 20 kHz. (Usually hearing capability decreases due to continuously listening to songs with head phones or staying in sound polluted areas.) If the frequency of sound is less than 20 Hz, it is called infrasound, and if the frequency of sound is greater than 20 kHz it is called ultrasound. If frequency less than 20 Hz or greater than 20

kHz is generated, then the movement created in air will not be heard by us. To detect such sounds we can use a special type of microphone or receiver. Many animals can hear sounds of low frequency. Before earthquakes, sounds of low frequency are generated, and often hearing this sound animals panic and leave the area.

Characteristics of sound wave

Sound is a mechanical wave, because sound wave is produced due to the vibration of body, and for its transmission an elastic medium is needed. This is a longitudinal wave, because the direction of propagation of the wave and the direction of vibration is the same. The velocity of sound depends on the property of the medium. In gaseous mediums its velocity is low, in liquids greater, and in solids it is much more. The velocity of sounds depends on the temperature and humidity of the medium. The intensity of sound is proportional to the square of the amplitude of the wave. Therefore, if the amplitude of a wave is high, the intensity of the sound will be high and if the amplitude is low, the intensity will be low.



Figure 7.12: "Phone" can be made by tying thread behind the plastic glass.



Do Yourself:

Take two plastic glasses. Make two small holes on the bottom of the glasses with a hot safety pin. Put thread through this hole and tie the thread inside the cup (Figure 7.12). Tie the two plastic glasses with long thread. One person should hold one cup and another should hold the second cup. One of you speaks, and the other person listens. (Keep the thread stretched, otherwise sound cannot be heard.) We are so used to hearing words in air; we think that sound goes only in air. This experiment is the proof that sound can propagate through liquids or solids like other medium too.



Example

Question: Sound of frequency 1 kHz is produced by a tuning fork. It was allowed to pass through air, water and iron. It was found that the velocity of sound in air is 334 m/s, in water is 1493 m/s and in iron 5130 m/s. What are the wavelengths in these mediums?

Answer:

Velocity of sound = λf , here λ is the wavelength, and f is the frequency. Here frequency is 1 kHz or 1000 Hz.

$$\lambda = \frac{v}{f}$$

$$\text{In air, } \lambda = \frac{334 \text{ m s}^{-1}}{10^3 \text{ s}^{-1}} = 0.334 \text{ m}$$

$$\text{In water, } \lambda = \frac{1493 \text{ m s}^{-1}}{10^3 \text{ s}^{-1}} = 1.49 \text{ m}$$

$$\text{In iron, } \lambda = \frac{5130 \text{ m s}^{-1}}{10^3 \text{ s}^{-1}} = 5.13 \text{ m}$$

7.3.1 Echo

Since sound is one type of wave, it can have reflection. If someone speaks in a big empty building it creates a reverberating sound. This is due to reflection. Within the building the distance is not enough to hear the sound separately. When we hear something the feeling persists for around 0.1 s, so to hear two sounds separately, it needs separation of 0.1 s differences between two sounds. Velocity of sound is 330 m/s, therefore to create a difference of 0.1 s, sound has to travel at least 33 m.

If we stand in front of a big wall, a building, or a high hill at least half of this distance (16.5 m), the sound will take 0.1 s to come back after being reflected and we will hear the reflection of sound or echo.

Bats have eyes and pretty good eye sight, yet they use echo during flight. While flying a bat uses its throat to produce sound, if there is an obstacle in the front, the sound returns after reflection, and the bat can estimate the distance from the time of the returning sound. For this reason, the bat can fly even in dark without being obstructed. We cannot hear the sound produced by the bat; because the sound is ultrasound i.e. frequency of the sound is beyond our hearing range. Bats can produce sound of frequency 100 kHz or more.

7.3.2 Variation of Velocity of Sound

In air, velocity of sound is proportional to the square root of temperature. i.e.

$$v \propto \sqrt{T}$$

Here the temperature is not Celsius temperature. Temperature in the Kelvin scale.

The velocity of sound does not depend on the air pressure. But it is inversely proportional to the square root of the density of air. So if there is water vapor in the air, its density decreases, hence velocity increases.

Sound is a mechanical wave. It depends on the elasticity of the medium. The nature of liquid and solid is different from air and naturally the velocity of sound is different there. In liquid the velocity of sound is more than that in air and in solid velocity of sound is even more than in liquid.

Table 7.0: velocity of sound in different medium

Medium	m/s
Air	330
Hydrogen	1,284
Mercury	1,450
Water	1,493
Iron	5,130
Diamond	12,000



Do Yourself

Put your ear at one end of a table, tell someone to knock at the other end. You will hear the sound of the knock clearly, because solid substances are much better medium for sound than air.



Example

Question: At a certain place, the temperature in the winter is 10°C and velocity of sound is 332 m/s, if the temperature is raised to 30°C in the summer what is the velocity of sound?

Answer:

$$v \propto \sqrt{T}$$

$$\frac{v_1}{v_2} = \sqrt{\frac{T_1}{T_2}}$$

$$v_1 = v_2 \sqrt{\frac{T_1}{T_2}} = 332 \sqrt{\frac{273 + 30}{273 + 10}} \text{ m/s} = 343.5 \text{ m/s}$$

7.3.3 Uses of Sound

We need not talk much about the common uses of sound. We speak, listen to songs, doctors hear the heart beat, engineers hear the sound of instruments etc. There are other applications of sound, which you may not have heard about. Previously we could not see from outside the fetus that grows in the womb of a pregnant mother; which is now possible with the help of a process called ultrasonography.

Three dimensional Seismic Surveys

Seismic Survey is done to explore whether gas or oil is present below the earth. To do this, a small blast is done a little below the earth. Sound of the blast hits the different layers of the soil and returns after reflection. The reflected wave is detected by a special type of receiver named a geophone (Figure 7.13). Analyzing all information a perfect three dimensional picture of the soil is formed, from which gas or oil is present or not is determined. Since we know the position of the source of sound and the geophone, the distance of the different layers of soil can be calculated accurately from the time required for the sound to reach from source to geophone.

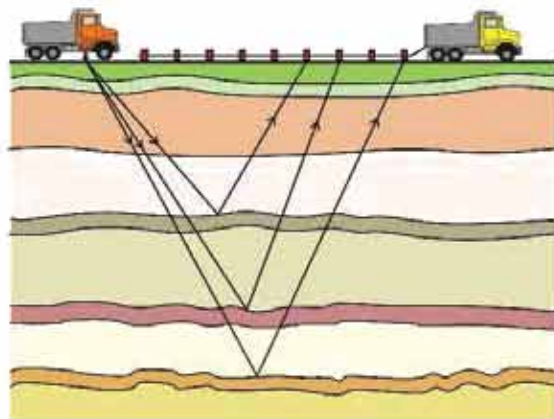

Figure 7.13: Information about different layers of the earth can be known, by the reflection of sound.

Ultrasound cleaner

Ultrasound cleaner is used when we need to clean small instruments perfectly in the laboratory. The small instruments are immersed in a liquid, and subjected to the ultrasound wave, the vibrations of which remove the dirt.

7.3.4 Musical Sound

We hear different kinds of sound, some of these sounds are sweet and some of them are annoying. The sweet sounds are the sounds of musical instruments. In figure 7.14 the waves of sound of some musical instrument are shown. You can see that all of them are periodic vibrations. In a tuning fork a perfect vibration is created. But in a musical sound there is not only a single wave, many waves superpose on one another to make the sound melodious.

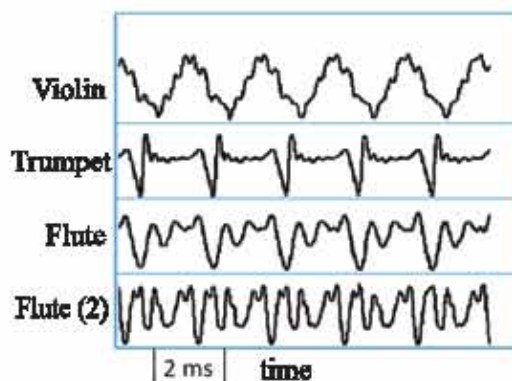

Figure 7.14: The sound waves of different musical instrument.

Among the many characteristics of musical sound, the important three are:

Intensity: Intensity is a measure of how loudly a musical sound can be heard. Therefore, the amount of sound energy that flows per second per unit area is called the intensity. The unit of intensity is Wm^{-2} .

Pitch: The characteristic of musical sound by which the sound of the same intensity is sometimes heard dull and sometimes sharp is called pitch.

Timber: The characteristics of sound by which we can differentiate the sound produced from different musical instrument is called timber or quality of sound.

Different types of musical instruments that are used to produce melodious sound, can be divided into three groups:

Musical instrument made of wire: Ektara (Monochord), Violin, Sitar

Musical instruments based on air flow: Flute, Harmonium

Musical instrument made of percussion: Dhol, Tabla

Now-a-days melodious sounds are produced using electronics in a completely different way.

7.3.5 Sound Pollution

Sound is essential in our life, but excessive sound makes our life intolerable. Those who live in cities, especially those who live besides a road observe that the sound produced from engines of bus, car, truck and of continuous horns goes beyond our tolerance limit very often. Most of the time we are used to living in such types of pollution for a long time. If we are fortunate enough to go to a quiet place where there is no sound pollution then suddenly we can realize the importance of life without sound pollution. The intensity of different types of sound are shown in Table 7.02.

Table 7.02: Intensity of sound of different types

Jet engine	110-140 dB
Traffic	80-90 dB
Car	60-80 dB
Television	50-60 dB
Conversation	40-60 dB
Breathing	10 dB
Sound of mosquito wings	0 dB

Due to sound pollution, we are losing our hearing capability. To intensify the problem many of us listen to songs using headphones in the ears.

To reduce sound pollution the first step is to make laws against it. The second step is to make public awareness. This issue has to be clarified to all, using horns while in cars as little as possible, installation of sound absorbing machine in the industry, making less uses of loud speaker, using vehicles of less sound etc. In addition, steps be taken of plantation of trees in the empty places in cities.



Exercise



General question

1. Show that a wave can transfer energy from one place to another.
2. Why is sound produced in whistle?
3. "When a wave propagates, the medium does not flow. It executes simple harmonic oscillation about its position", True or False?
4. Why is sound produced in a thunderstorm?
5. What problem would arise for a bat if it creates infra-sound instead of ultra-sound when flying?

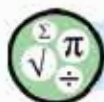

Mathematical questions

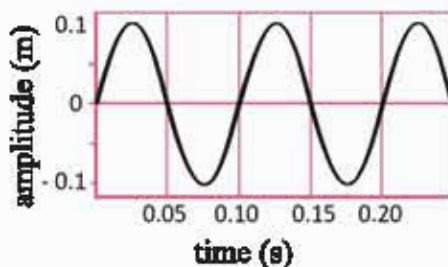
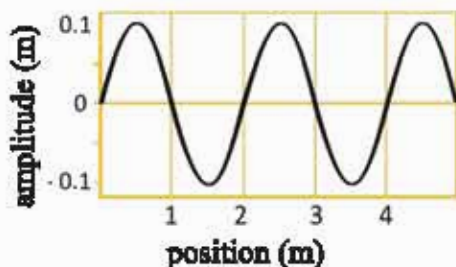

Figure 7.15: A wave with respect to time and position

1. A wave is shown in Figure 7.15 with respect to time and position. What is the velocity of the wave?
2. The ratio of velocity and velocity of sound is called *MACH*. What is the velocity of the fighter plane *MACH* 9?
3. In summer, the velocity of sound is increased by 0.5 % in a town. If the temperature in winter is 10°C , what is the temperature in the summer?

4. We can hear sound from 20 Hz to 20 kHz. What are the wavelengths of sounds of 20 Hz and 20 kHz?
5. $dB = 10 \log \left(\frac{P_2}{P_1} \right)$, here P_2 and P_1 are the sounds of a Jet plane and of a mosquito respectively, how many times larger is the sound of a Jet plane than that of a mosquito?



Multiple choice questions

Put tick (✓) mark on the correct answer

1. What type of wave is sound?
 (a) Transverse wave (b) Electromagnetic wave
 (c) Longitudinal wave (d) Radio wave
2. In which medium is the velocity of sound maximum?
 (a) Solid (b) Light
 (c) Gaseous (d) Plasma
3. Why is a dead bat seen hanging from an electric line?
 (i) The bat lacks a clear idea about the position and distance between the two electric lines instantly.
 (ii) It did not hear the echo of ultrasonic sound ahead.
 (iii) It is hanging with one wire and touching the other.

Which one of the following is correct?

- (a) i and ii (b) i and iii
 (c) ii and iii (d) i, ii and iii

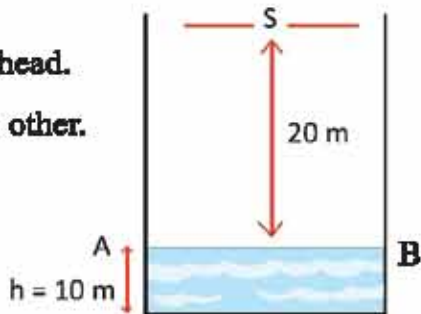

Figure 7.16

In Figure 7.16, S is a source of sound and AB is the surface of water. Answer questions 4 and 5 on the basis of the given information and the figure considering the velocity of sound as 332 m/s .

4. What will be the maximum height of water to hear the echo?
- (a) 13.40 cm (b) 13.40 m
(c) 3.40 m (d) 3.40 cm
5. How much time is required to hear the echo in case of the given figure?
- (a) 0.10 s (b) 0.12 s
(c) 0.14 s (d) 0.18 s



Creative questions

1. Rafsan is taking his test examination of class ten. His physics exam is on the next day. There is a marriage ceremony in their neighboring house. The music was played loudly there till 2 am at night. This loud music hampers his studies very much. His father is a patient of high blood pressure. It is also uncomfortable for him.

- (a) What is sound pollution?
(b) Explain the causes of sound pollution.
(c) What troubles may Rafsan's father face due to sound pollution? Write down the effects of sound pollution on public health.
(d) What measures can be taken to prevent sound pollution?

2. Using the information given below and based on Figure 7.17 answer the following questions.

- (a) What is periodic motion?
(b) Why is water wave a transverse wave? Explain.
(c) Find the wavelength of sound.
(d) Is it possible to hear echo at position S? Verify the mathematical logic.

Frequency of sound = 1200 Hz

Air temperature = 30°C

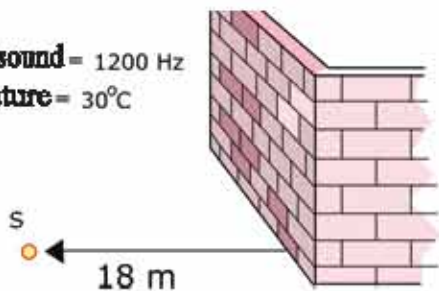

Figure 7.17

3. During summer vacation, Nusrat visited Sajek with her family. To hear an echo she screamed loudly beside a hill. But, hearing no echo, she felt sad. Then her father told Nusrat to move 3 m and to make a sound. This time Nusrat heard the echo. On that day, the velocity and frequency of sound was 332 m/s and 1328 Hz .

- (a) What is an echo?
- (b) Why is a minimum distance necessary to hear an echo?
- (c) What is the wavelength of sound produced by Nusrat?
- (d) How far does Nusrat have to move backward if she wants to hear an echo after 0.3 s of screaming?

Chapter Eight

Reflection of Light



When light reflects on the objects around us and comes into our eyes, we can see those objects. In the previous chapter we have learned about sound as a wave. In this chapter we will learn about light as a wave. This wave is a different kind of wave, called an electromagnetic wave.

When light is reflected on a plane mirror, it creates an image. All of us are familiar with this image. If a curved mirror is used instead of plane mirror, it will create a different kind of image. We will discuss different types of images in different mirrors in this chapter.



By the end of this chapter we will be able to-

- explain the nature of light.
- explain the laws of reflection of light.
- explain mirrors.
- explain images.
- explain the formation of images in mirrors by drawing action line of light rays.
- explain some common phenomena of formation of images in mirrors.
- explain uses of mirrors.
- explain magnification.
- demonstrate formation of images.
- understand the influence of different optical phenomena and their contributions in our life.

8.1. Nature of Light

What we see with our eyes is light. We see trees, the sky, chairs and tables, human beings, but that doesn't mean that these are light. Light reflects from these objects and comes into our eyes, and the retina of our eyes creates and sends signals to our brain. Then our brain can recognize whether it is a tree or a human being. The whole process starts with light entering into our eyes.

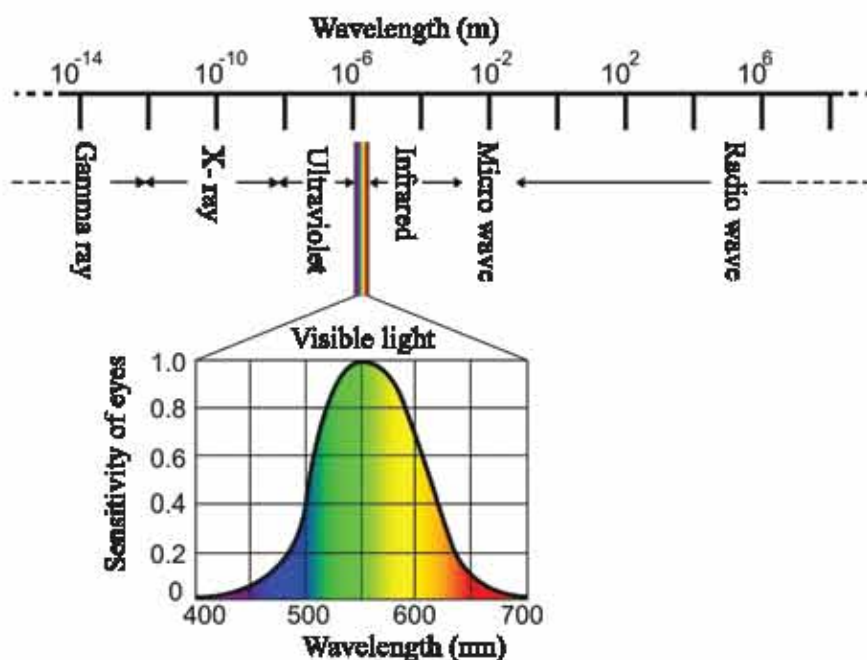

Figure 8.01: Spectrum of light and sensitivity of eyes to different colors

Light is an electromagnetic wave. Every wave has a wavelength, which means light also has a wavelength. Those of us who have produced waves by throwing a stone in a pond or by shaking a rope know that we can create waves of different wavelengths if we desire. So light may have different wavelengths. Electromagnetic waves may have any wavelengths.

These wavelengths may be greater than a few kilometers or may be one trillionth parts of one meter. We can only see a small part of this possible large range of wavelengths.

We cannot see it if the wavelength is larger or smaller than this range. If the wavelength is from 400 nm to 700 nm, we can see the electromagnetic wave, and we call that light. The colors we see in our eyes are actually lights of different wavelengths. When the wavelength is less, it becomes violet. When the wavelength increases, the light gradually becomes blue, green, yellow, orange, and red, and at one point it disappears! Human eyes cannot see beyond this range- but various insects or other living beings can see outside this range. The sensitivity of human eyes to different colors of light is shown in Figure 8.1.



Do Yourself

Hold a CD in the sunlight and reflect the light on a nearby wall. You can see the full spectrum of light on the wall. CDs have sharp indentations which work as grating and separate the colors.

In Figure 8.01, the name of different wavelengths is shown. If the wavelength is less than the smallest wavelength of visible light, then we call it ultraviolet light. If the wavelength is even smaller than it is called x-ray, and even smaller is called gamma ray- which comes out from radioactive nucleus. If the wavelength is larger than the largest wavelength of visible light, we call it an infrared ray. If it gradually becomes larger we call them microwave, and then radio waves! To learn physics this division of wavelengths is one of the most important topics.



Do Yourself

We cannot see infrared rays with naked eyes because of their high wavelengths. A TV remote emits infrared rays that we cannot see. You may see this through mobile phone camera because a special type of light sensitive IC named CCD is used, which can detect some infrared light with visible light.

You can see that the wavelengths of visible light are very short but there are many interesting experiments in physics, using these we can perform various interest experiments of this wavelength.

If we want to know more about light, we can start with reflection.

8.2. Reflection

If we talk about reflection what we imagine is standing in front of a mirror, but reflection is much more than that. When light is sent from one medium to another, three different phenomena occur simultaneously. One of them is reflection and the other two are refraction and absorption. (Figure 8.02)

While traversing from the first medium into the second medium, if a part of light returns to the first medium, the phenomenon is called reflection. Some parts of it may enter the second medium which is called refraction and some of it may be absorbed which is called absorption. In this chapter we will discuss reflection and in the next chapter we will discuss refraction.

It has been said earlier that light is a wave. Generally a wave needs a medium to travel, (If there is no water how will a wave be created in it). But this is different in case of light. As this is a wave consisting of electric and magnetic fields, so light does not need any medium to travel. Light can create its wave of electric and magnetic fields and can propagate by itself. So when we talked about the first and second medium for reflection or refraction, one of this medium can even be vacuum. To speak the truth, the examples we see for reflection and refraction in glass or water, there, one medium is glass (or water) and other is air. Air is such a light medium that we can consider it as a vacuum.

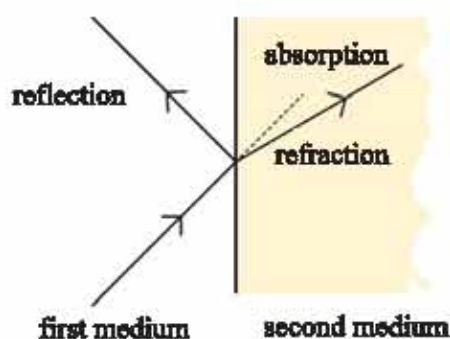

Figure 8.02: Reflection, refraction and absorption of light from one medium to another.

8.2.1 Laws of Reflection

Before understanding the laws of reflection, we need to define some terms. When light is incident from one medium to another, for the time being we assume that it is a plane surface. To understand better, we will assume that the light that reflects is a light ray or a light beam. When a light ray from the first medium to the second medium is incident on a point, first we have to imagine a perpendicular at that point which is called a normal. Then imagine a plane that contains this incident ray and the normal (Figure 8.03).

The ray, which is incident at a point, from the first to the second medium is called the incident ray (XO). The ray which is reflected (OX') is called the reflected ray. (You are realizing that the ray which enters the second medium is the refracted ray- we will not discuss it in this chapter). The angle between the incident ray and the normal is called the incident angle (θ_i) and the angle between the reflected ray and the normal is the reflected angle (θ_r). Now we can state the two laws of reflection:

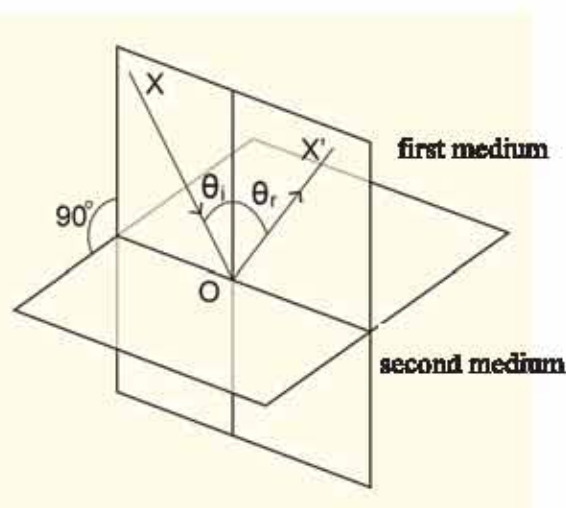

Figure 8.03: Reflection of light from first to second medium

First Law: The reflected ray will be in the plane which we imagined through the incident ray and the normal.

Second Law: The reflected angle is equal to the incident angle.



Example

Question: Two mirrors are placed as shown in figure 8.04. A candle is placed at point X between the mirrors. Where image of the candle will be formed?

Answer: The image will be seen in the mirror. An image of that image will be seen eventually in two mirrors. Therefore, as shown in the figure, an infinite number of images will be formed.

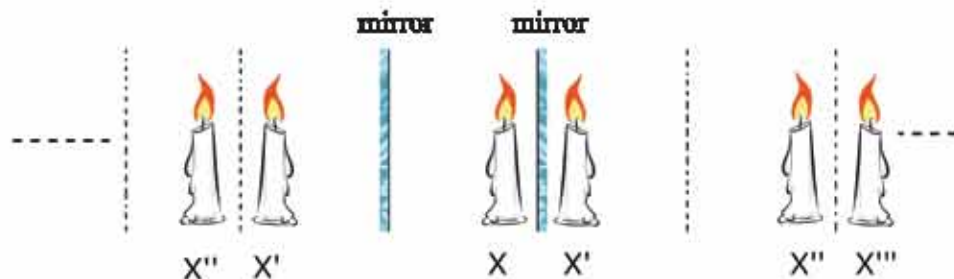

Figure 8.04: If a candle is placed between two parallel mirrors, the image X' and image of image X' i.e. X'' , X''' ... will be formed.

Here two laws of reflection have been stated. But everything about reflection is not yet discussed. The most important matter has not been discussed yet, that is how much will it reflect? If a mirror is used for reflection, it reflects fully. But the word reflection is not only meant for mirrors, it may occur between any two mediums. Fresnel's law describes how much it will reflect. You will learn more about it in higher classes. The main thing is, the larger the angle of incidence, the more the amount of reflection (Figure 8.05). In normal glass, light is reflected slightly (only 4–5%), and the rest is refracted through the glass. But if the angle of incidence is higher (like 80° or 90°), then reflected light increases greatly. You can test it standing beside a window.

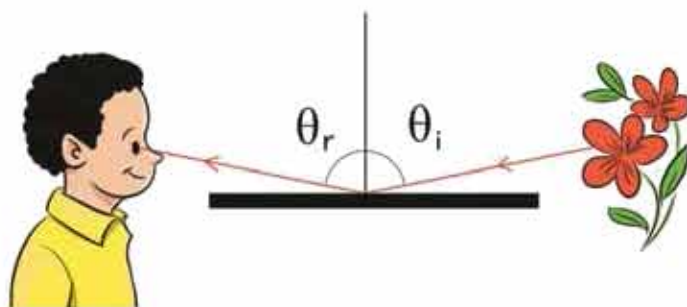

Figure 8.05: Reflection increases for higher incident angle

Absorption

Much of the beauty of the world around us comes from different colors. But how does the color appear? Why is the color of a rose red and a leaf green? You will be even more surprised to see a red rose as black under green light or a green leaf as black under red light!

This is actually very easy to explain; in normal light (sometimes called white light) every wavelength is present. Since colors depend on the wavelength of light, it can be said that light of all colors are present there. When all colors are present together, then individual colors are not seen separately- then we say the light is colorless or white light. When this light falls upon a red rose, then the rose absorbs all the colors except red. The light that reflects and come to our eyes, only has red and we see the rose appears as red.

Similarly, when light of all colors falls upon a green leaf, it reflects only green light and absorbs others, so we see the color of the leaf as green. (Figure 8.06)

If the rose and leaf are seen under full red light then the flower will appear red as it does not absorb red color but the leaf will appear black. Because the leaf will absorb the color red and will not reflect any color. So we will see the leaf as black. Similarly, under green light we will see the leaf green but the rose black. Because the red rose will absorb the green light totally and no light will be reflected from the rose, so it looks black.

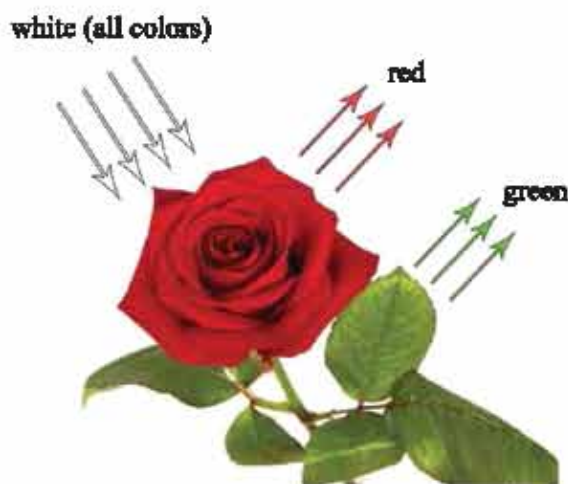

Figure 8.06: Absorbing all colors which colour is reflected by an object that is considered its color.

8.2.3 Reflection from smooth and rough planes

Parallel light rays become parallel after reflecting from mirrors or smooth plane surfaces because each ray obeys the law of reflection and reflects with an angle of reflection equal to the angle of incidence. Even if the plane is not smooth, every ray of light will obey the law of reflection. But the rays are incident at different angles at different points of the plane, therefore the rays will reflect in different angles after reflection. After reflection, the reflected rays are not parallel and spread in different directions. (Figure 8.07) These types of reflections are called irregular reflection.

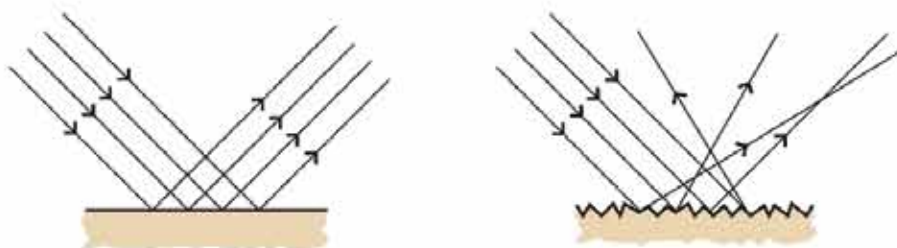

Figure 8.07: Light reflects from smooth surfaces and scatters from rough surfaces

8.3 Mirror

All of us have seen mirrors. In a mirror a clear image is formed due to uniform reflection. A silver layer is placed behind a glass mirror for proper reflection. 4% light is reflected from the front part of a mirror, but the back part reflects fully and forms the original image. When the original image is very important in optical instruments like telescopes, the silver or aluminum layer is coated on the glass surface, so that the two images, one 4% lighter and other 96% clear are not formed, rather it forms a 100% clear image.

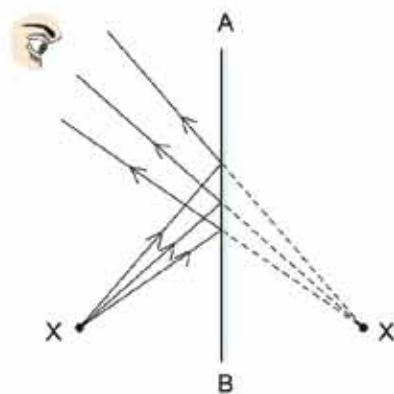

Figure 8.08: The image of X object will form in X' position.

8.3.1 Image

When you stand in front of a mirror, you see your own image. The closer you stand; the image seems to appear at the same distance behind the mirror. In figure 8.08, X is an object from which three rays have been reflected in mirror AB (therefore, incident angle = reflected angle). If we extend the rays behind the mirror it will seem to converge to a point X'. This point is the image of object X. For a real object, there are infinite number of points and each point forms an image and collectively makes the image of the object.

If we want to define the position of the image using geometry we need to draw at least two rays. It will be easier to draw the picture if we consider XP (normal to the plane) and XO as ray as shown in figure 8.09. Triangle OPX and OPX' are congruent. Therefore $XP = X'P$, which means the image has formed at a distance equal to the distance of the object from the mirror.



Example

Question: Show that, triangle OPX and OPX' are congruent.

Answer: Here, $\angle XPO = \angle X'PO$ because both of them are at right angles, as XP is normal to the plane. According to the law of reflection, incident angle is equal to angle of reflection, therefore, $\angle XOP = \angle ROA$. Again $\angle ROA = \angle X'OP$.

Therefore, between triangle OPX and OPX', OP is the common arm and two angles on both sides are equal. So, triangles are congruent

Therefore, $XP = X'P$.

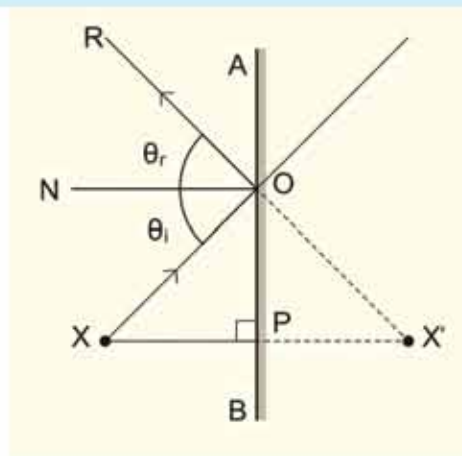

Figure 8.09: Two light rays XP and XO are sufficient to draw an image of the object at position X

The image we see in a mirror is not actually real even though it seems real. This is because light is not actually coming from the place it appears to be coming.

Later, we will see that sometimes images are really formed by converging light and light rays come from there. This type of image is called a real image and it is possible to do many things with this type of image. In case of the image formed in a mirror, light does not actually come from the image, so this is virtual image.

Figure 8.10, shows how an image is formed for an extended object instead of a single point. Light coming from points X and Y reflect from the mirror and form a virtual images at point X' and Y' respectively, light appears to be coming from X' and Y' . You can clearly see that length of XY is equal to the length $X'Y'$. If the arrow head of XY is on top, the arrow head of $X'Y'$ will also be on the top.

So the image in a mirror is:

- (a) Equidistant from the mirror
- (b) Virtual
- (c) Straight and
- (d) Equal to the size of the object

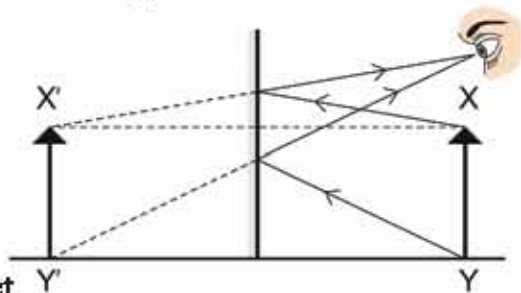

Figure 8.10: XY object's image $X'Y'$

We are reminding these separately, because later we will find that if we use mirrors of other types instead of plane mirrors, the image may form at different distances, may be real, may be inverted, may even be small or large.



Do yourself

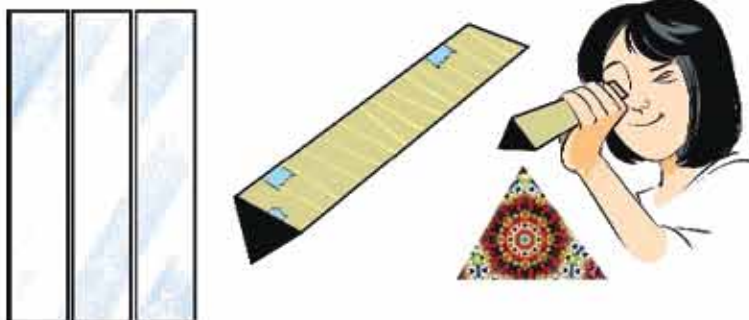

Figure 8.11: Kaleidoscope can be made using three glass pieces.

Take three pieces of glass of similar size (you can find this from photo-frame stores). Form a triangular shape with these three pieces and wrap them with paper. Stick them in a triangular shape with glue as shown in Figure 8.11. Cover one side with thin paper. Now put some colourful stones or colored beads or pieces of bangles inside it and look from the other side. You will see some beautiful patterns. This setup is called a kaleidoscope. If you rotate this instrument, you will see the patterns in movement. Continuous reflections on the glass create this pattern. You may think that in normal transparent glass the reflection is less, but in a kaleidoscope the incident angle is larger, therefore the amount of reflection is also higher.



Example

Question: What is the required length of a mirror to see a full-length image?

Answer: From the geometry shown in Figure 8.12, it can be said that the length of the mirror is 0.75 meter. The interesting thing is that, whether you stand at a distance of 1 m or 10 m from the mirror, the size of the mirror needs to be half of the length of you for you to see your whole body. If your mother or father or anyone wants to buy a full-length mirror, you may suggest them to buy a half-length mirror!

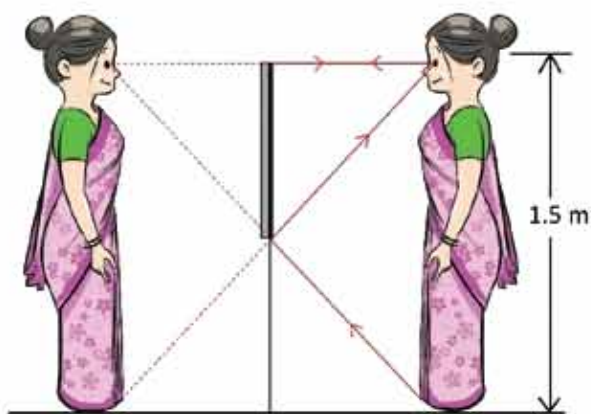

Figure 8.12: To see the full image it is not necessary of a full length mirror.

Question: Two mirrors are placed mutually at 60° angle (Figure 8.13). If light is incident on the first mirror at an angle of 60° , what will be the direction of light?

Answer: From geometry it can be said that the ray will incident on the point B perpendicularly, and reflect in the opposite direction.

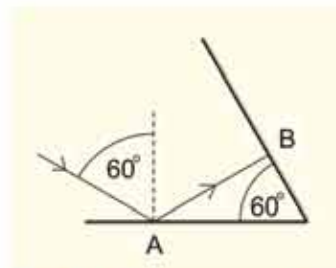

Figure 8.13: Two mirrors kept at an angle of 60° , light is incident at point A on a mirror at an angle 60° .



Individual work

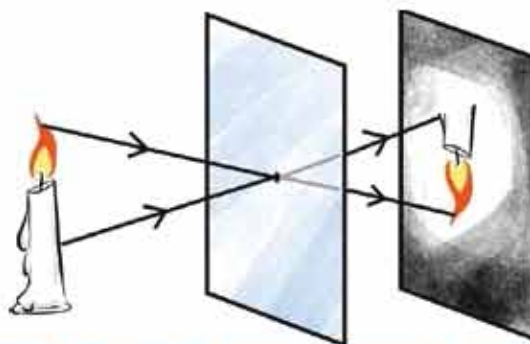

Figure 8.14: Image of an object can be formed using fine holes.

In a dark room, make a very small hole in the middle of a piece of cardboard and place a candle before it. On the opposite side of the board, hold a white paper, as shown in Figure 8.14. If you do not allow any other light to fall on the white paper, you will see an image of the flame of the candle. By moving the white paper in forward or backward, the size of the image can be made small or big. Is the image real or virtual? Straight or inverted? Is it equidistant or not? Large or small?

You can understand, the image is real, inverted, clear at all distances and as far as it forms, larger in size. Through this process, a pin hole camera is made.



Example

Question: As shown in Figure 8.15, two mirrors AO and BO are placed perpendicularly to each other. Hold your left hand in front of it. Now draw the images of your hand.

Answer: Your hand is in AOB. In A'OB is the front-back image of your hand. In AOB' is the up-down image of your hand. Notice that in both cases your left hand image appears to be your right hand. In A'OB' you will see the image of the image.

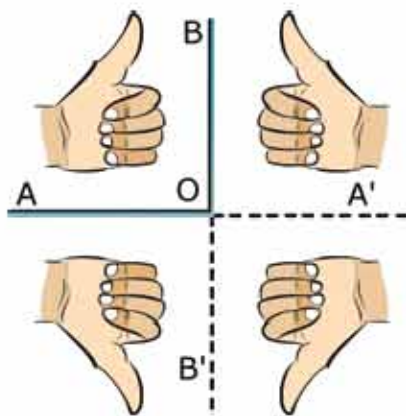

Figure 8.15: Different reflections of the left hand grip in two mirrors kept perpendicularly

This can be the up-down image of A'OB or can be the front-back image of AOB'. Notice that after one reflection your left hand seems to be your right hand, but after two reflections (reflection of the reflection) your left hand appears as your left hand.

8.4 Spherical Mirror

We all have seen ordinary plain mirrors but may not have seen a real spherical mirror. But the main concept of a spherical mirror can be seen in a new shiny spoon. Spherical mirrors are of two types- concave and convex. We can make concave or convex mirrors by cutting a portion of a hollow sphere and coating its surface with a silver or aluminium layer. Whether the spherical mirror will be concave or convex depends on which surface is coated with silver or aluminium.



Figure 8.16: The opposite plane of a spoon works as convex mirror.

8.5 Convex Mirror

An actual convex mirror is a part of a real sphere. Let, the radius of the sphere be r (Figure 8.17). A part of it has been cut to make provision for reflection of light from the convex side.

If a parallel light beam is incident on the mirror, the light will scatter in all directions. If we extend the scattered light rays towards the center of the mirror, it will seem like they have come from a point. This point is called the focal point. The center point of the surface of a convex mirror that reflects the light is called pole and the distance of the focal point from the pole is called the focal length (f).

We can imagine a spherical mirror as a part of a sphere. If the radius of this sphere is r , its focal length would be $= r/2$.

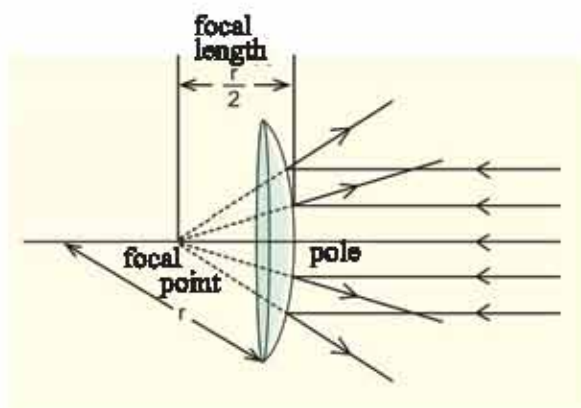

Figure 8.17: Focal length of a convex mirror is half of the radius of the sphere.



Example

Question: Prove that, $f = r/2$

Answer: Interestingly, you cannot prove this completely. You can only go close to it. Let two rays parallel with the principal axis of a spherical mirror

come from A and B respectively. The first ray has come to point X and the second one has come to another point Y. The ray coming to point X will be reflected back the way it has come. Let us extend this ray to the center of the sphere, O. We can see that $OX=r$ (radius of the sphere). The ray coming from point B to point Y will create an angle of incidence θ_i with perpendicular ON at that point. The angle of reflection of the ray BY is θ_r and it will be reflected towards YP. If we extend PY, it would intersect line OX at point F.

$FO=FY$ because in the triangle OFY, $\angle FOY = \angle OYF$, as $\angle FOY = \theta_i$ and $\angle FYO = \theta_r$.

$FY \cong FX$ when XY is small compared to radius r. This is true for most convex mirrors.

So, $FO = FY = FX = r/2$
or focal length $f = r/2$

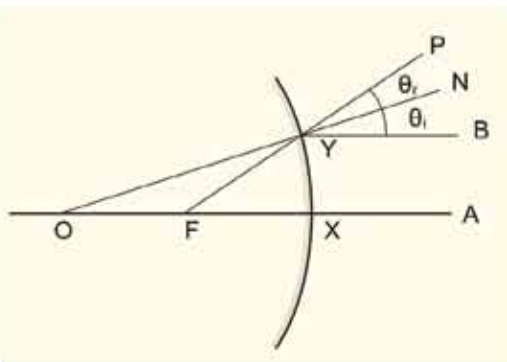

Figure 8.18: A spherical convex mirror is a small part of a hollow sphere.

Question: If a plane mirror is considered a spherical convex mirror then what is its focal length?

Answer: Infinite.

We will now see how the image is formed for a spherical mirror. You will see that in a convex spherical mirror, images are always virtual whereas in a spherical concave mirror it may be both real or virtual, depending on the position of the object.

8.5.1 Image in a Spherical Convex Mirror

We have already said that the outer part of a spoon acts as a spherical convex mirror. You can see an upright and small image of yourself there. This means that the image in a convex mirror should always be small.

To understand how an image is formed in a spherical convex mirror, we first need to understand how light rays reflect on such a mirror. This depends on what angle the light rays are incident on the mirror. If we know the rules of reflection of only three special light rays, we can easily explain how an image is formed:

- (i) If light rays are travelling towards the center (Figure 8.19, XN or YR ray), they are reflected perpendicularly and go back along the line they were as incident on.
- (ii) If light rays travel parallel to the principal axis (Figure 8.19, XP), they will appear to have diverged from the focal (F) point.
- (iii) If the direction of the light ray is changed, it goes back the way it has come. When the light ray is travelling towards the focus (Figure 8.19, QP), it will be reflected parallel to principal axis (PX).

We can now create an image using these three rules. In figure 8.19, an object XY is kept in front of a convex mirror. The light ray travelling from point Y towards R will be reflected back along the same path towards Y, which means the image of the point Y will be created somewhere along the line YO. To know exactly where the image is formed, we have to draw another light ray from the point X in another direction but that's not necessary because we will find it by knowing where the image of point X is formed.

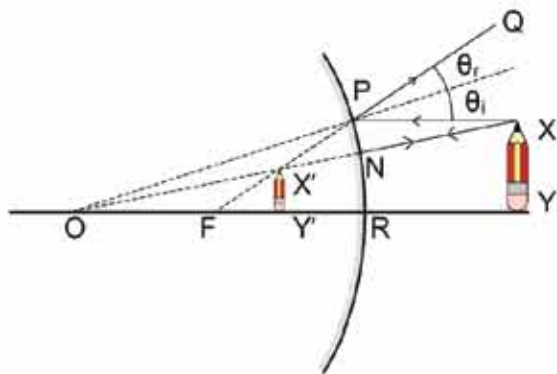

Figure 8.19: In convex mirror if an object XY is placed inside focal length, the image X'Y' looks smaller.

To find the image of the point X we have to draw two rays, one by connecting the points X and O as we have done before. (As the YR ray was reflected back to the point Y, similarly this ray will be reflected back towards X from the point N on the mirror.) The second ray can be drawn parallel to YR, which will be incident on point P of the mirror and will appear to have diverged from the point F. So we join the line FP and extend it towards Q.

The line FP intersects line OX at the point X' i.e. the image of the point X will be formed on the point X' . The perpendicular drawn from X' to OY will intersect line OY at Y' . Since it appears that the reflection of X is coming from point X' , similarly it will appear that reflection of Y is coming from Y' . Hence, $X'Y'$ will be the image of XY .

We can observe that $X'Y'$ is always smaller than XY and the further XY is from the convex mirror, the smaller $X'Y'$ will get! One should know how to draw the image of an object placed in front of a concave or convex mirror using the laws of reflection. It is a very important procedure in physics.

It is clear that actually no light is coming from $X'Y'$, it just appears that the image is there. Hence it is a virtual image. Comparing this with the images formed by a plane mirror, we can see that-

- The position of this image will be between the focus and pole of the mirror. The further the object is, the closer the image to the focus.
- This image is virtual.
- This image is upright.
- This image is small, and the further the object moves from the mirror, the smaller the image becomes.

8.6 Concave Mirror

The inner side of a shiny spoon is an example of a concave mirror. Those of you who have looked at the inner side of a spoon must have noticed (Figure 8.20) that the image is small, and the interesting thing is that the image is inverted! You can take your finger very close to the spoon and notice that the finger is upright. Now move your finger slowly away from the spoon, notice that your finger is starting to look bigger (we were able to produce images in plane mirror or convex mirror but never images larger than the real size of the object this is the first time we are seeing larger



Figure 8.20: A spoon works as a concave mirror

image). If you move your finger away slowly then you will notice at one point, that the image gets inverted! No matter where you are while moving away from that point, it will always remain inverted. (We were never able to create inverted images using plane mirrors or convex mirrors— this is the first time we are observing an inverted image!)

So you can see that the outside part of a spoon works as a convex mirror and the inside of a spoon works as a concave mirror! A real concave mirror is actually a part of a sphere. In the case of a convex mirror light was reflected from the outside convex shape and in the case of a concave mirror light will be reflected from the inside concave shape.

If parallel rays are incident on a concave mirror the light rays will converge at a point after reflection (Figure 8.21). You can understand that this point is the focal point of the concave mirror and the distance from the pole to this point is known as the focal distance. Light rays don't have any option of stopping, so after converging at a point they will travel straight forward and it will look like light is diverging from that point! Therefore before reaching the focal point the rays are converging (convergent) and after reaching the focal point the rays are diverging (divergent).

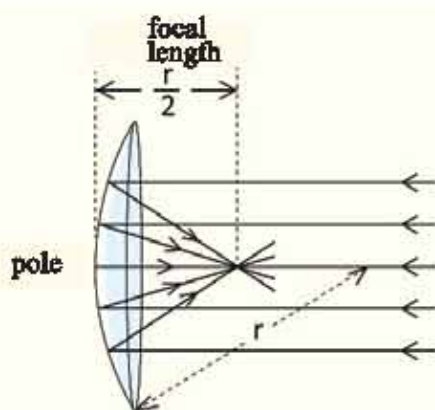

Figure 8.21: The focal distance of a concave mirror is half of the radius of the sphere



Example

Question: If we imagine a plane mirror as a spherical concave mirror, what will be its focal distance?

Answer: Infinite!

We got the same answer in case of convex mirrors, which means when the focal distance increases to infinity then both convex and concave mirrors turn into plane mirrors! The focal distance is half of the radius in concave mirrors as in a convex mirror.

8.6.1 Image on concave mirror

Now we have entered the most exciting part! In plane mirrors and convex mirrors only one type of image was formed. Two types of images can be formed on a concave mirror. If an object is placed within the focal distance it forms one type of image, if it is placed at a distance greater than the focal distance it creates another type of image.

Before starting that, let us know how light rays reflect from a spherical concave mirror. If we know the rules of reflection of three special light rays in a concave mirror, we can explain how the image is formed:

- (i) If light ray travels along the radius or starts from the center (Figure 8.22, OP or ON ray), it will reflect perpendicularly and go back the way it has come.
- (ii) The ray parallel to the principal axis will go through the focal point (F) after reflection (QF).
- (iii) If the direction of light ray is changed, it goes back the way it has come. So a light ray (figure 8.22, FQ) going through the focus will reflect parallel (QX) to the principal axis.

Now we can create image for concave mirrors.

At a distance less than focal length

In Fig 8.22, a concave mirror is shown. This mirror is part of a sphere whose center is O, focal point of the mirror is F and we want to determine the image of the object XY. Light coming from point Y reflects from point P of the concave mirror and again goes through point Y towards point O. So it can be comprehended that it will stay on a point of line OP or on an extended part of line OP. To determine this exact point another ray has to be drawn from point Y towards the concave mirror, but we are not doing that. If we can determine the image of the point X as before we can find the exact location of the image of point Y. To determine the image of point X, two lines have to be drawn from this point. The first line will be an extended part of the line OX. It will touch the

concave mirror perpendicularly and after reflection will go back the way it has come. As shown in figure, another ray from point X can be a ray parallel to the principal axis. Because we have already known that parallel ray goes through the focal point after reflection. So it will be incident on the point Q and after reflection will go through the point F.

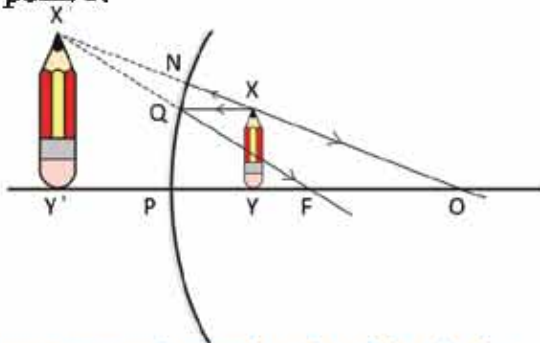

Figure 8.22: Image appears larger than the object in the concave mirror placed inside the focal length.

After emerging from point X two rays of light will travel towards NO and QF and we can see that these two rays have no chance of intersecting. So there cannot be an image formed on the right side. But if we are able to look at the left side from the right side then it will look like line ON and line FQ coincide at X' point- so X' will be the image of X. If we draw a perpendicular from this point on OP axis then we will get X'Y' which is the full image of XY. No light is coming from X'Y', only we are thinking that the image is being formed there. So this image is a virtual image. We can see from the figure that the image is larger than the object. Not only will the image be larger but moving the object closer to the focal point will create a yet larger image. (If the object is placed just on the focal point then the reflected rays will become parallel meaning that the light rays won't be able to coincide to create an image.)

Now let's see what happens to the image when we place an object within the focal distance of a concave mirror:

- The position of the image will depend on the position of the real object. The closer the object is placed to the focus further the image will be created.
- It is virtual
- Straight
- The length of the image will also depend on its position, the closer it gets to the focal point the larger its length becomes.

At a distance greater than focal distance

Among all the images we have seen so far, this image is amazing, because we will witness a real image for the first time, where light will be centralized where the image will be created (Figure 8.23).

Let, the object be XY and like other cases, the image of point Y will be on the line YP . We have to draw two lines in order to determine the image of point X . One line XQ will be parallel to the axis, and after reflection it traverses through the focal point F as QF . We can draw the second ray through the point F . This will reflect in the concave mirror and after reflecting, it will become parallel to RS , as after reflection in the concave mirror parallel rays traverse through the focal point, the reverse is also true. Light always follows its path in reverse direction. Lines QF and RS intersect at the point X' and point X' is the image of point X .

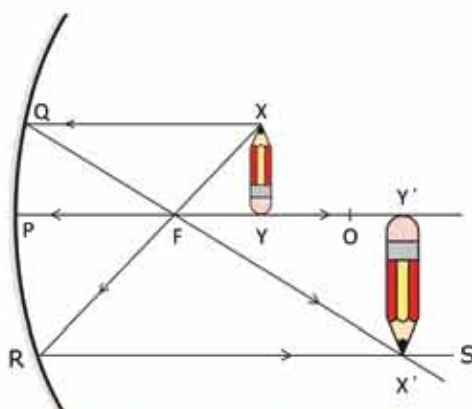

Figure 8.23: The image becomes inverted if an object is placed outside focal length of a concave mirror.

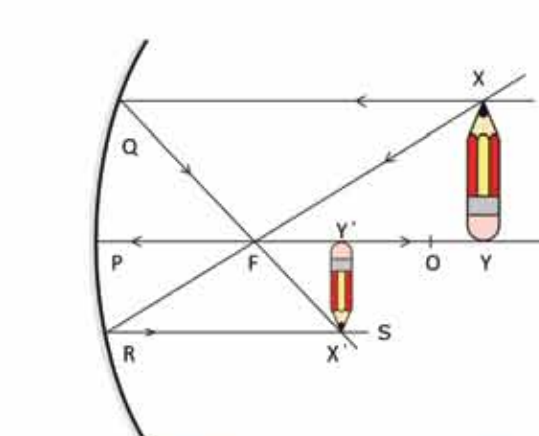

Figure 8.24: In a concave mirror if an object is placed at a distance more than two times of focal length the image formed is inverted and short

So, the normal drawn on line PO from X' intersects at the point Y' and $X'Y'$ is the image of object XY . This image is unique compared to other images. This is shown in Figure 8.24. The object XY is placed at a distance more than two times of focal distance. This time the image has become shorter. If the object is placed at a distance of two times of focal length, its image would appear on the same point as shown in Fig 8.25. Not only this, the image's size

would be the same as the object. These three different cases can be written precisely when the object is outside the focal distances. If any object is placed outside the focal length, the images will be as follows:

- (a) The position of the image depends on the position of the object. When the object is placed within the focal point and at concave mirror's center, the image will be formed outside the center. As the object is placed outside the center of curvature of the concave mirror, the image be formed inside the center. If the object is placed at the center, the image will also form at the center.
- (b) The image is real. So, as we can say that if the image itself is the object, the object becomes the image.
- (c) The image is inverted.
- (d) The height of the image will depend upon its position. If it is formed in between the focal point and the center of curvature, the height of the image will be greater than the object. The nearer to the focal point, the greater it is. If the object is outside the center of curvature, its height will be shorter than the real object. If the object is placed at the center of curvature, the size of the image will be the same as the object.

We applied geometry to determine the position, shape etc. of images for convex and concave mirrors. We could do these works using a single formula. The formula is :

$$\frac{1}{u} + \frac{1}{v} = \frac{1}{f}$$

Where, u is the distance of object from the plane of the mirror, v is the distance of the image and f is the focal distance.

Real image is a very important idea. We will find in the next chapter how real images can be formed with a lens. You have already seen that there are real light rays in a real image, so if it is projected on a screen, it is possible to see the image. In ordinary mirrors, you can look at yourself but you cannot project yourself on screens with ordinary mirrors.



Example

Question: Figure 8.24 shows that the image of object XY is formed at X'Y'. If the object is X'Y', where will the image be formed?

Answer: This is a real image. So if X'Y' is an actual object, the image will be XY.

Question: : If an object is placed just at a distance double of its focal length in a concave mirror, where will the image be formed?

Answer: (Figure 8.25) The image will be formed at the same position, be of the same size but in inverted form.

Till now we have learnt the science of concave mirrors, now we will see how to use it.

8.7. Magnification

We have seen that an image can be larger or smaller than the real object, this is called magnification. Magnification refers to how large the image is than the real object. If the length of an object is l and length of its image is l' , then magnification is

$$m = \frac{l'}{l}$$

When we see an object through a telescope, how large the object is when seen with the naked eye as compared to its size as seen by a telescope is known as the telescope's magnification.

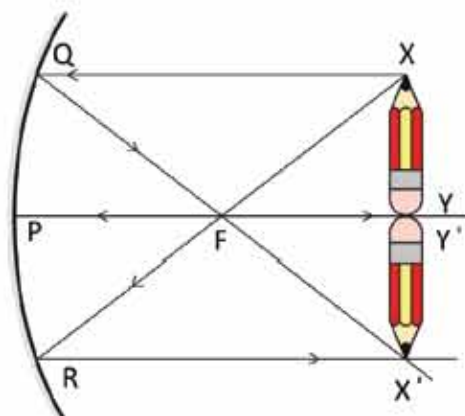

Figure 8.25: In concave mirror, if an object is placed at a distance double of its focal length, the image will form at the same position in inverted condition.

8.8 Use of Mirror

8.8.1 Plane Mirror

Simple mirrors are most commonly used in our daily lives. Ordinary mirrors are used whenever a light ray travelling in one direction is to be redirected in another direction. You must have noticed that in a plane mirror right and left side alternates. So if we want to keep the right and left unchanged, the image of one mirror is to be reflected by a second mirror.

The left and right sides are interchanged in a plane mirror image. Right and left do not interchange if two mirrors are used as a single mirror by keeping them at 90° angle with each other. You may demonstrate it by using two mirrors (Figure 8.26).

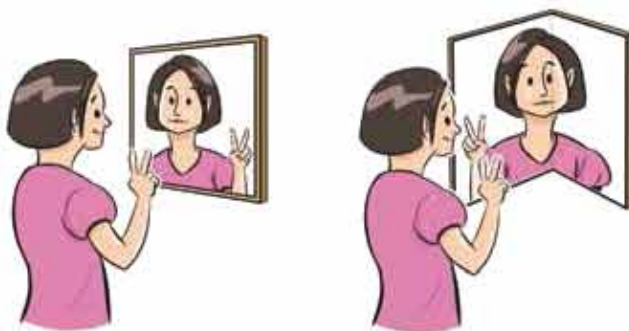

Figure 8.26: In ordinary mirror the left and right are interchanged, where as two mirrors are kept at right angles to leave left and right unchanged.

An important point to note is, when a good reflection is necessary, quite a different kind of reflection is done instead of using an ordinary plane mirror. We will see in the next chapter how light is reflected by a completely transparent medium.

8.8.2 Convex Mirror

A diminished and erect image can be created by using a convex mirror. So a convex mirror is used to see a large scene in a small region. Expert drivers always trying to notice of what is happening behind the car while driving. So,

there is a rear view mirror in front of the driver. Convex mirrors are used in these mirrors so that drivers can see a vast area behind the car with the help of a small mirror.

8.8.3 Concave Mirror

The most important use of concave mirrors is in telescopes. Concave mirrors are used in the largest and the smallest telescopes of the world. Many of us generally think that the only function of a good telescope is to create a large image of the small objects situated far away. Actually that's not true, the function of a good telescope is also to create a distinct image in very dim light. That is why the bigger the concave mirror is, the more light it can converge to create a clear image. Concave mirrors are used in all of the large telescopes of the world.

Another use of concave mirrors is to create a parallel beam of light. Concave mirrors are used in search lights of ships or launches. The light source is kept at the focus of the mirror, so the light rays are incident on the concave mirror and reflected back as parallel beams of light. The torch lights you use in your daily life, also have the bulb kept just at the focus of a concave mirror!

Since an erect and magnified image is formed when an object is placed within the focal length of a mirror, we use concave mirrors if we want to see a magnified image of any object. Doctors and dentists often use concave mirrors when they try to observe something.

8.8.4 Safe Driving

Development of the transportation system of a country is necessary when a country is trying to develop. New roads are constructed and vehicles of many types start moving on those roads. You must have noticed that the huge number of vehicles travelling through the roads in our country and how the number of vehicles is increasing day by

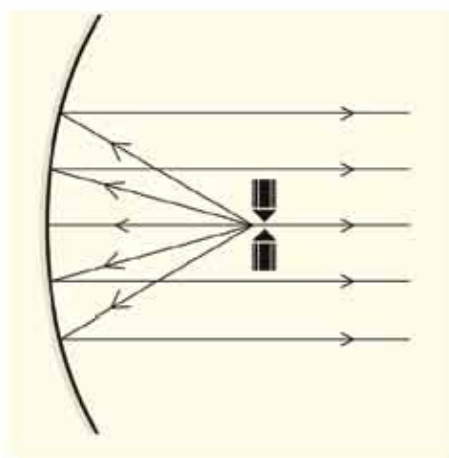

Figure 8.27: When an intense light source is placed at the focal point, then that light is reflected at the concave mirror as parallel beam of light.

day. A huge amount of time is wasted because of traffic jams created due to insufficient roads and many people die due to accident on highways. These deaths occur mainly due to the reason that drivers jeopardize safe driving for reaching destinations quickly rather than safely. Many kinds of awareness is required for safe driving, correct use of light is one of them.

Brake lights play an important role while driving. Seeing this light the driver of the preceding car can be sure if the car in front is trying to slow down or in which direction the car will go. Whether the car will change lanes or not, the turn lights are used to inform others. The head lights in front of the car illuminates the dark roads but there are some specific rules for using headlights. The high beams are not used when a car is coming from the opposite direction so that the eyes of the driver are not dazzled by the bright lights. A driver has to be aware of the sides and back of the car besides the front. That's why there's a rear view mirror in front and side view mirror on both sides of the car. Convex mirror are used here so that an image of a large area can be created in such a small mirror. A good driver always keeps track of what is happening on all sides of the car as well as what's happening in front of the car.

8.8.5 Invisible Curves of Hilly Roads

Hilly roads are usually curved as well as uneven. Besides, there are hills on one side and a deep ditch on the other side of the road. This is why the drivers should be careful while driving on hilly roads. Still driving in some areas can be very risky. Especially when there is almost a 90° turn ahead and the driver cannot see what is coming from the other direction. In these circumstances, a plane mirror is placed at 45° at the turns. Then the drivers can see what's happening on both sides and driving in those areas becomes comparatively safe.



Exercise



General questions

1. How the sensitivity of eyes can be determined?
2. Why are the danger signals shown in red colors though human eyes can see yellowish green the most?
3. In mirrors, right and left interchange, Why do the top and bottom not interchange?
4. Why colors cannot be seen in moonlight?
5. Why concave mirrors are used in the telescopes used by astronomers?
6. What do you mean by reflection of light?
7. What do you mean by regular and irregular reflection?
8. What is a mirror?
9. What is called an image? How many types of images are there? What are they?
10. How is real image formed in a concave mirror? Demonstrate with the help of a ray diagram.

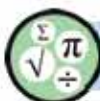

Mathematical questions

1. A mirror is placed as shown in figure 8.28. In which direction will the light ray, shown in figure 8.28, go?
2. For a convex mirror (figure 8.29a) show where the image will be formed for an object XY by drawing a ray diagram.
3. For a concave mirror (figure 8.29 b) show where the image will be formed for an object XY by drawing a ray diagram.

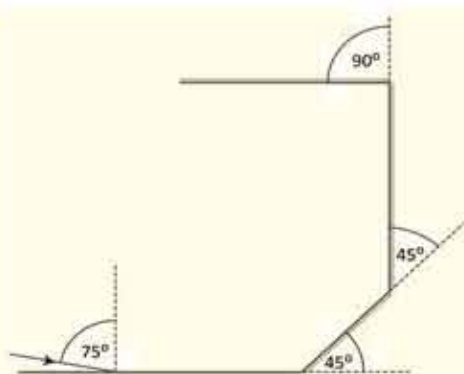

Figure 8.28

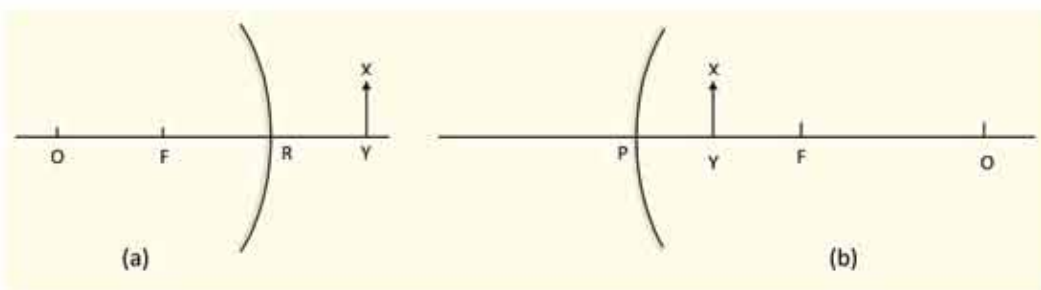

Figure 8.29: (a) An object placed inside the focal length of a convex mirror.
 (b) An object placed inside focal length of a concave mirror.

4. For a concave mirror (figure 8.30a) show where the image will be formed for an object XY by drawing a ray diagram.

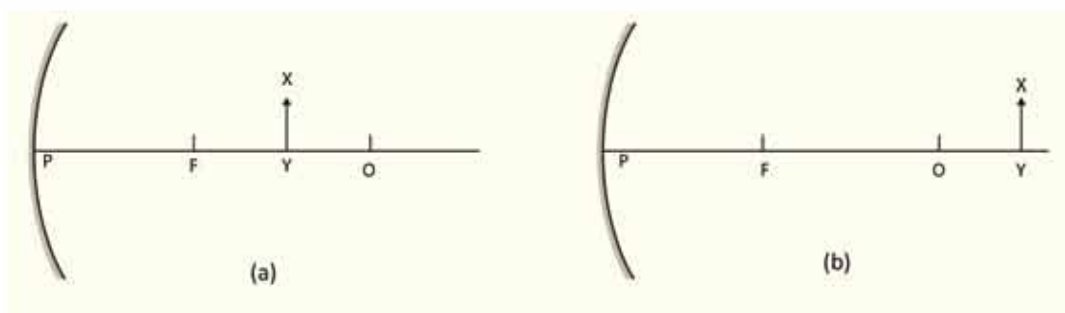

Figure 8.30: (a) An object placed outside focal length in concave mirror.
 (b) An object placed outside focal length in concaves mirror.

5. For a concave mirror (figure 8.30 b) show where the image will be formed for an object XY by drawing a ray diagram.



Multiple choice questions

Put the tick (✓) mark on the correct answer.

1. Where are convex mirrors used?

(a) Cars

(b) Torch light

(c) Solar oven

(d) Radar

2. How many types of reflections are there?

- (a) 4 (b) 3
(c) 2 (d) 1

3. Image produced in a plane mirror -

- (i) equal to object in size
(ii) can be formed on a screen
(iii) formed at a distance equal to the distance of the object from the mirror.

Which one of the following is correct?

- (a) i and ii (b) ii and iii
(c) i and iii (d) i, ii and iii

Answer question number 4 and 5 in light of the above figure.

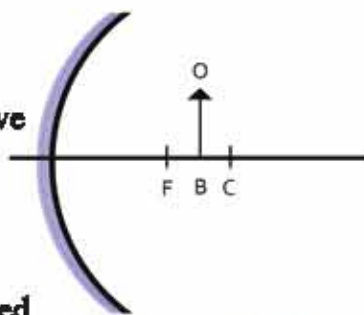

Figure: 8.31

4. What will be the size of object BO?

- (a) magnified (b) diminished
(c) extremely magnified (d) extremely diminished

5. What will be the position of the object BO?

- (a) between the focus and the pole (b) at the principal focus
(c) at the centre of curvature (d) between the centre of curvature and infinity



Creative questions

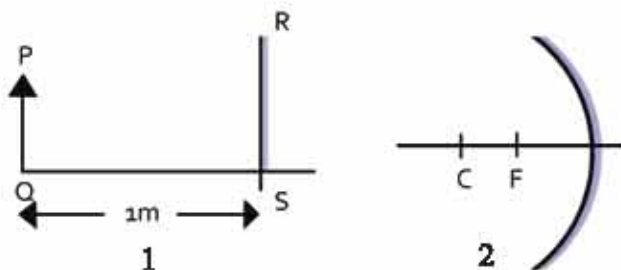

Figure 8.32

1. Figure 8.32

- What is a plane mirror?
- Why is a metal coating given behind a mirror?
- Determine the position of the image of the object PQ by drawing a figure.
- Compare the mirrors 1 and 2 in the formation of images.

2. Figure 8.33

- What is an image?
- Why rays incident normally on the mirror turns back along the same path?
- Determine the value of the angle of reflection in light of the figure above?
- The image formed in the plane mirror PQ is virtual; explain with the help of diagram.

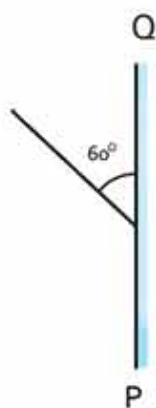

Figure 8.33

3. A group of students found that if a stick of 2 cm length is placed in front of a concave mirror, an image of 3.51 magnification is formed on the screen in the first step. In the second step of the experiment they found an image on the screen of magnification 6.

- What is magnification?
- Why plain mirrors are not used as view mirrors?
- Calculate the length and property of the image of the stick in the first step of the experiment.
- What are the changes made in the second step of the experiment?

Chapter nine

Refraction of light

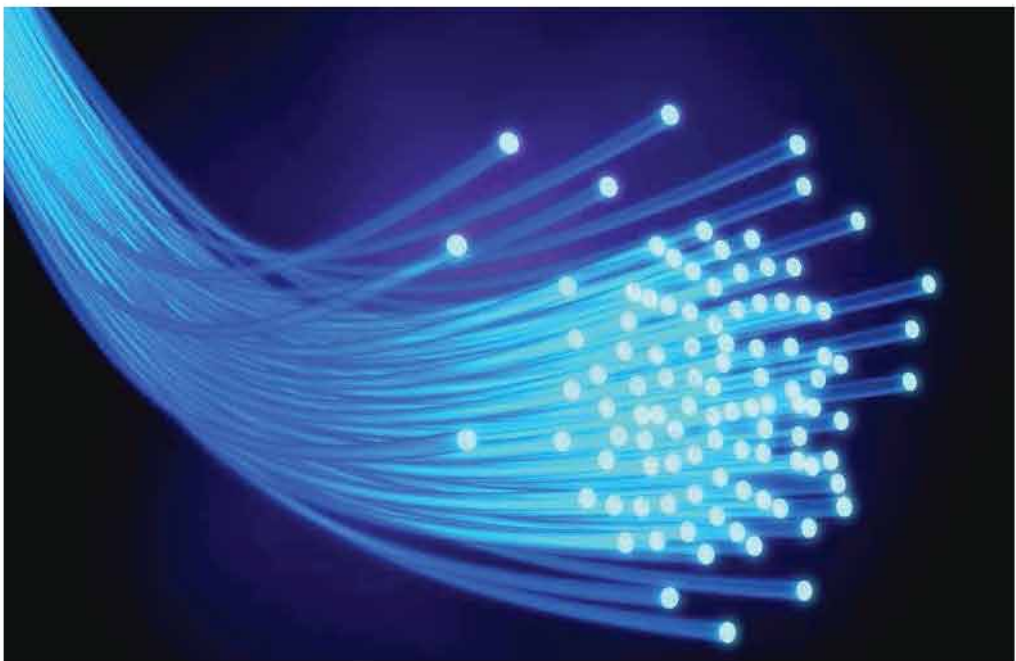

The velocity of light in a vacuum is $3 \times 10^8 \text{ ms}^{-1}$. If light enters a medium, its velocity decreases from this velocity. To explain this process a quantity named refractive index is defined. You can easily show that light changes its direction due to the change of its velocity while passing from one medium to another. Due to this property of light, or refraction, a wonderful event may happen named total internal reflection. We will discuss various uses of total internal reflection in this chapter.

Convex and Concave lens can be made by using refraction. Which type of images can be formed using these two lens will be discussed in this chapter.



By the end of this chapter we will be able to-

- explain the laws of refraction.
- explain the refractive index.
- explain total internal reflection.
- explain the use of optical fibers.
- describe lenses and their classification.
- describe different qualities of lens by drawing a ray diagram.
- describe the image formed by lenses by drawing a ray diagram.
- describe the power of lenses.
- describe the function of eyes by drawings ray diagram.
- describe the least distance of distinct vision.
- describe the defects of eyes.
- describe the uses of lens to remedy the defects of the eye by drawing ray diagram.
- explain the perception of coloured objects.
- describe the uses of refraction of light in everyday life.

9.1 Refraction of light

You know that when light moves from one medium to another, three different events may happen. One is reflection, where some amount of light come back to the first medium while entering the second medium and we have discussed this in the previous chapter. Another one is refraction, when light passes from the first medium to the second. We will discuss this in this chapter. Another one is absorption, when some amount of light is absorbed, which we will not discuss here.

In order to understand refraction a quantity named the refractive index (n) is used. We know the velocity of light in a vacuum is $2.99 \times 10^8 \text{ ms}^{-1}$ and when it passes through a medium this velocity decreases. In a medium, the factor by which the velocity of light reduces is the refraction of light of that medium. For instance the velocity of light in water is $2.26 \times 10^8 \text{ ms}^{-1}$ therefore the refractive index of water is

$$n = \frac{c}{v} = \frac{2.99 \times 10^8 \text{ ms}^{-1}}{2.26 \times 10^8 \text{ ms}^{-1}} = 1.33$$

i.e. the velocity of light in a vacuum is 1.33 times greater than the velocity of light in water.

The refractive index of the glass fiber in a fiber optic cable is 1.5.

Therefore, the velocity of light in the fiber is

$$v = 3 \times 10^8 \text{ ms}^{-1} / 1.50 = 2.00 \times 10^8 \text{ ms}^{-1}$$

Refractive index is a number and it has no unit. As the maximum velocity of light is c , the value of n always greater than 1. In

Table 9.01 the refractive index of some substances are given.

Naturally, the refractive index of a vacuum will be 1.

The refractive index of air is 1.00029 which is so close to 1 that we will take it as 1 during calculations.



Example

Question : Calculate the velocity of light in the mediums shown in Table 9.01.

Answer : Velocity of light in any medium: $v = \frac{c}{n}$

Table 9.01: Refractive index of some substance

Vacuum	1.00
Air	1.00029
Water	1.33
Normal glass	1.52
Diamond	2.42

$$\text{In vacuum } v = 3 \times 10^8 \text{ ms}^{-1}/1.00 = 3 \times 10^8 \text{ ms}^{-1}$$

$$\text{In air } v = 3 \times 10^8 \text{ ms}^{-1}/1.00029 = 3 \times 10^8 \text{ ms}^{-1}$$

$$\text{In water } v = 3 \times 10^8 \text{ ms}^{-1}/1.33 = 2.26 \times 10^8 \text{ ms}^{-1}$$

$$\text{In normal glass } v = 3 \times 10^8 \text{ ms}^{-1}/1.52 = 2 \times 10^8 \text{ ms}^{-1}$$

$$\text{In diamond } v = 3 \times 10^8 \text{ ms}^{-1}/2.42 = 1.24 \times 10^8 \text{ ms}^{-1}$$

To determine the refractive index of a medium is, the wavelength of light for which the refractive index is measured must be stated, because the refractive index depends on the wavelength of light.

9.1.1 Laws of refraction

What we need to understand the laws of refraction are already known. In the case of reflection of light we have imagined a normal from the point of incident. We do the same here. In Figure 9.01 we will call the angle between the incident ray and the normal as the angle of incidence and the angle between the refracted ray and the normal as angle of refraction.

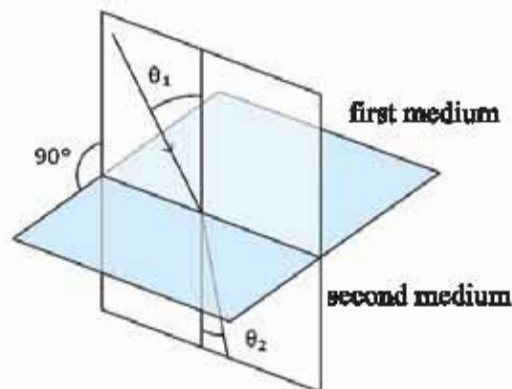

Figure 9.01 : Refraction of light from first medium to the second

First Law of Refraction: The refracted ray will lie on the same plane as the incident ray and the normal.

Second Law of Refraction: If the refractive index of the first medium is n_1 , the refractive index of the second medium is n_2 , the angle of incidence is θ_1 , the angle of refraction is θ_2 , then

$$n_1 \sin \theta_1 = n_2 \sin \theta_2$$

If you remember this, you will be able to solve all problems about refraction of light.

If the first medium is air then taking $n_1 = 1$, (Figure 9.02)

we can write

$$n_2 = \frac{\sin \theta_1}{\sin \theta_2}$$

As the value of n_2 is greater than 1, $\theta_2 < \theta_1$ i.e after refraction, the ray of light will bend towards the normal. We say the medium is denser if the value of n is greater. We are not calling the medium denser due to its mass. Here the meaning of a denser medium is that the value of n is more. Therefore, according to the second law of refraction, when a ray of light enters from a rarer medium to a denser medium, the refracted ray bends towards the normal. When it enters from a denser medium to a rarer medium, it goes away from the normal (Figure 9.02).

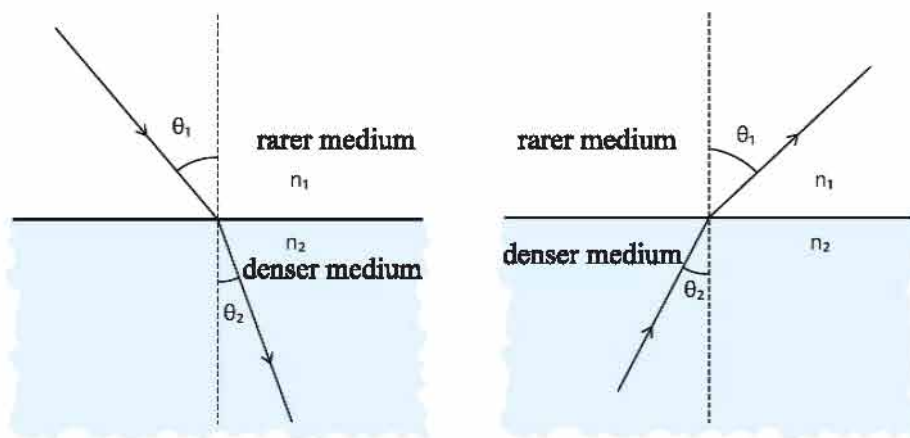

Figure 9.02 : The refracted ray bends towards the normal when entering from a rarer medium to a denser medium, and it goes away from the normal when entering from a denser medium to a rarer medium.

Here only the incident ray and refracted rays are drawn, as refraction of light is discussed, but we must remember that when a ray of light goes from one medium to another every time some amount of light is reflected. How much light will be reflected and how much light will refracted depends on the angle of incidence. When there is an increase in the angle of incidence, the reflection increases.



Do Yourself



Figure 9.03 : Refraction of light in water and glass

Put a coin in a cup and place the cup in front of you so that the coin is not seen. How is it possible to see the coin without moving your head? After pouring water in the cup, the coin will be seen. Due to refraction light will bend and reach your eyes. It will also seem as if the coin has moved upwards.



Example

Question: A ray of light is incident on a medium of $n = 1.6$ with an angle of incidence 45° (Figure 9.04 a). With what angle will it enter into the second medium?

Answer: We know $n_1 \sin \theta_1 = n_2 \sin \theta_2$

Therefore
$$\sin \theta_2 = \frac{n_1}{n_2} \sin \theta_1 = \frac{1}{1.6} \times \frac{1}{\sqrt{2}} = 0.44$$

$$\theta_2 = 26^\circ$$

Question : In Figure 9.04 b, a ray is incident from air to another medium at an angle of 60° and refracted at angle of 45° . What is the refractive index of the second medium?

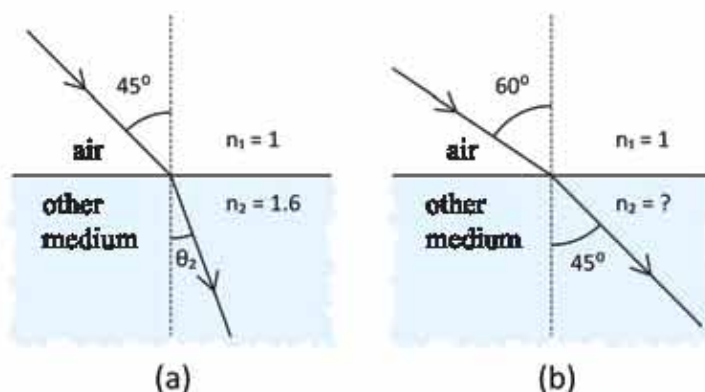

Figure 9.04: (a) Angle of incidence of light is 45° (b) Angle of incidence is 60° and angle of refraction is 45°

Answer : We know $n_1 \sin \theta_1 = n_2 \sin \theta_2$

$$1 \times \sin 60^\circ = n_2 \sin 45^\circ$$

$$n_2 = \frac{\sin 60^\circ}{\sin 45^\circ} = 1.22$$

9.1.3 Relative refractive index

We said that the refractive index of a medium is always greater than 1. Because, as the refractive index of a medium is a comparison of the velocity of light in that medium with the velocity of light in a vacuum, it will be greater than 1. Sometimes the refractive index of a medium is expressed in comparison with another medium. Then the refractive index may be less than 1 depending on which medium is being compared with which.

For example, if water is the first medium and glass is the second medium (Figure 9.05) then

$$n_1 \sin \theta_1 = n_2 \sin \theta_2$$

$$n_1 = 1.33$$

$$n_2 = 1.52$$

The refractive index of glass compared to water:

$$\frac{n_2}{n_1} = \frac{\sin \theta_1}{\sin \theta_2} = 1.14$$

which is greater than 1.

The refractive index of water while compared to with glass

$$\frac{n_1}{n_2} = \frac{\sin \theta_2}{\sin \theta_1} = 0.88$$

which is less than 1.

You therefore divide the refractive index of the medium that you want to determine by the refractive index of the medium with respect to which you want to determine the refractive index .

Diamond with respect to water : 1.82

Water with respect to diamond : 0.55

Diamond with respect to glass : 1.59

Glass with respect to diamond : 0.63

But in physics usually the refractive index of a particular substance is used, not the refractive index of one substance in comparison to another.

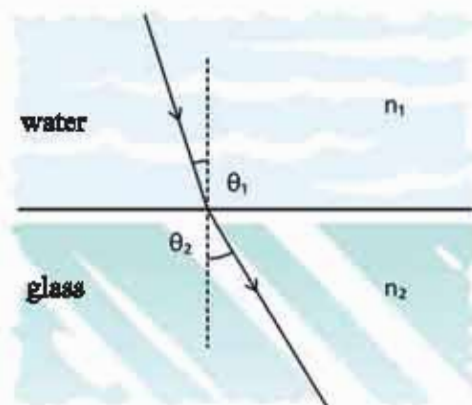

Figure 9.05: Refraction of light from water to glass

9.2 Total Internal Reflection

When discussing reflection, we learned that when perfect and total reflection is needed, then instead of mirror a perfect transparent medium is used, and a kind of reflection is made. This is called total internal reflection. It is a very easy and exciting process. Here, light rays are sent to a rarer medium from a denser medium using the refraction of light. We know (and have used many times) that the law of refraction is $n_1 \sin \theta_1 = n_2 \sin \theta_2$ i.e if n_2 is greater than n_1 then θ_1 is greater than θ_2 . Suppose you are sending a ray of light from a denser (n_2) medium to a rarer (n_1) medium (Figure 9.06). According to the laws of reflection and refraction some amount of light will be reflected and some will be refracted. As θ_1 will be greater than θ_2 therefore staying $\theta_2 (90^\circ)$, θ_1 will be equal to 90° and after this there will be no scope of light to be refracted, i.e when θ_1 will be equal to 90° , total light has to be reflected. The value of θ_2 at which $\theta_1 = 90^\circ$ is called the critical angle θ_c .

$$n_1 \sin 90^\circ = n_2 \sin \theta_c$$

$$\sin \theta_c = \frac{n_1}{n_2}$$

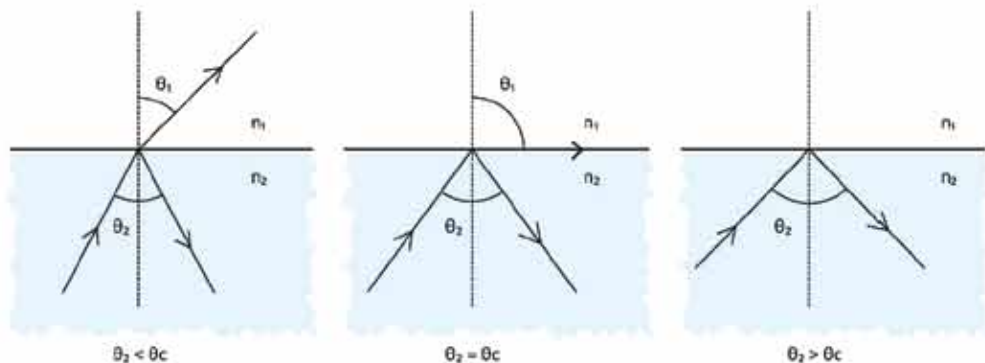

Figure 9.06: When passing from a denser medium to a rarer medium, total internal reflection of light may occur .

i.e $n_1 \sin 90^\circ = n_2 \sin \theta_c$

or $\sin \theta_c = \frac{n_1}{n_2}$

If we know the values of n_1 and n_2 we could calculate an angle θ_c for which the above law is true. Therefore, the law can be expressed as

$$\theta_c = \sin^{-1} \left(\frac{n_1}{n_2} \right)$$

n_2 for glass = 1.52 and

n_1 for air = 1.00

$$\frac{n_1}{n_2} = \frac{1.00}{1.52} = 0.66$$

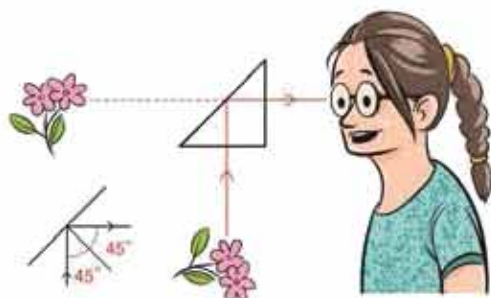

Figure 9.07 : Most teasing reflection occurs in total internal reflection .

It is possible to show that, $\sin 41.8^\circ = 0.66$ or $\sin^{-1}(0.66) = 41.8^\circ$,
therefore the critical angle $\theta_c = 41.8^\circ$

When sending light from transparent glass to air, if the ray of light is incident at an angle greater than 41.8° , the ray of light will not emerge from transparent glass and will be totally reflected. If you have a prism then you will be able to see total internal reflection with your own eyes. In Figure 9.07, at the glass-air separating surface the incident angle is 45° , which is greater than the critical angle 41.8° of glass-air. Therefore total internal reflection will occur here.



Example

Question : What will happen if you want to do this experiment under water ? (n_2 for glass is 1.52 and n_1 for water is 1.33)

Answer: In water $\frac{n_1}{n_2} = 0.88$, therefore the critical angle of glass will be 61.6° because $\sin 61.6^\circ = 0.88$
or $\sin^{-1}(0.88) = 61.6^\circ$

As the angle of incidence is 45° , which is less than the critical angle 61.6° , total internal reflection will not occur.

Question : Light incidents at an angle of 75° from a medium of refractive index 1.45. With what angle will the ray of light emerge if there is air on the other side.

Answer : We know

$$n_1 \sin \theta_1 = n_2 \sin \theta_2$$

$$1.45 \times \sin 75^\circ = 1 \times \sin \theta_2$$

$$\sin \theta_2 = 1.40$$

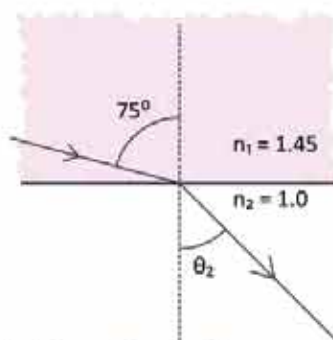

Figure 9.08 : Light incidents at angle 75° .

We know the value of $\sin \theta_2$ will not be greater than 1, but here it happens because light is totally reflected without refracting. Therefore whenever we want to see the refraction of light from a denser medium to a rarer medium then it is better to determine the critical angle first. If light incidents at an angle less than this critical angle, only then it is possible to get refraction.

In this case if the critical angle is θ_c

$$\sin\theta_c = \frac{1}{1.45} = 0.69$$
$$\theta_c = 43.6^\circ$$

Therefore, if light incidents at angle 75° , then total internal reflection will happen instead of reflection.

9.2.1 Rainbow

You may be thinking that you have never seen total internal reflection. But those who have seen a rainbow have seen total internal reflection. A rainbow is formed by the total internal reflection of water. Those who have not separated white light into different colors with prism, have seen this in a rainbow. If the sun shines after rain, we see a rainbow. Because there are water droplets in the air, in that water total internal reflection occurs, where different colors of light bends in different angles. The bands of different color of the rainbow are formed by these light rays. Those of you who have seen a rainbow have seen that the rainbow always forms in the sky opposite to the sun. Surely now you have understood the reason for this.

9.2.2 Mirage

Mirage is a common phenomenon in the desert. You will be surprised to hear that a mirage also happens due to total internal reflection. The word comes from changes of density of air due to heat in the desert. We know heated air, being lighter, goes up, but due to the heated sands in the desert the nearby air may be hotter than the upper air. Therefore, we can imagine the air in desert as in Figure 9.09.

In order to illustrate this easily only a few layers are shown. The density of the air in upper level is high and so the refractive index is high. Air in the lower level is heated, so density is low and its refractive index is also low. During refraction of light from the tree, in each layer the angle of refraction will increase and at the lowest level total internal reflection may happen. When entering a medium of lower refractive index from a medium of higher refractive index there is a

possibility of crossing the critical angle because the angle of incidence is higher if it is seen from far. So a mirage is seen from far and cannot be seen from near. If a person looks at a tree from far away, he can see the tree directly, and due to total internal reflection he can also see an image of that tree under the tree. It will seem that the image of the tree is seen due to the existence of water under the tree. After coming closer, it will be clear that there is no water.

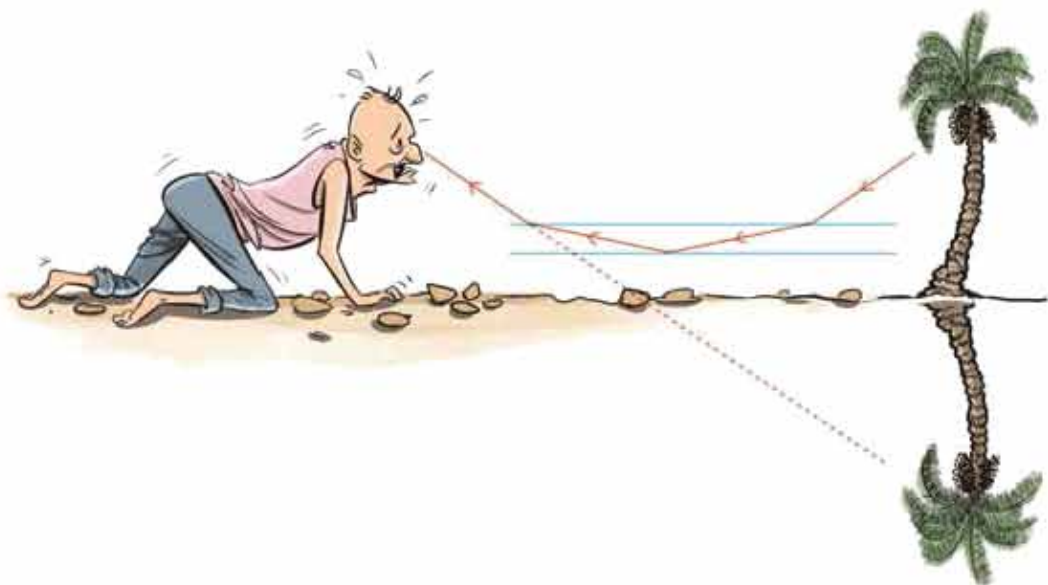

Figure 9.09 : Mirage is seen due to the difference of density of the air in the desert.

While driving a car on a heated road in the summer, a wet road is seen far away for the same reason. After coming closer it is seen that the road is dry. This is also a kind of mirage.

9.3 Uses of refraction

There are different uses of refraction. The uses which play important roles in our lives are:

9.3.1 Optical fiber

Electric wire is replaced by thin glass fiber for communication of the new world.

In the past, information was sent with electric signals; now information is sent with light signals. In a free state light goes in straight line, but in an optical fiber the light is trapped so it is possible to turn it in any direction by rotating on any side.

An optical fiber is a very thin fiber of glass. The inner part of it is called the

core and the outer part is called clad. Although the two are made of same glass, the refractive index of the inner part (core) is greater than that of the outer part. For this reason light can be taken very long distances by trapping it in optical fibers through total internal reflections (Figure 9.10). Light can be taken hundreds of kilometers through optical fibers, because the absorption of light in optical fibers is very low. Absorption would have been greater if the visible light was there so infrared rays of long wavelength are used in optical fibers. How optical fibers are used in a process called endoscopy of medical science is described in the last chapter.

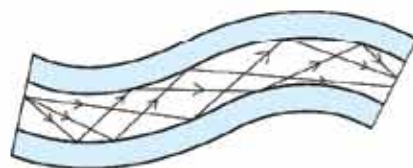

Figure 9.10: Light can pass through optical fiber by total internal reflection.



Example

Question: If the refractive index of the core in an optical fiber is 1.50 and the refractive index of the clad is 1.45, (Figure 9.11) what is the angle of incidence of light for total internal reflection to occur?

Answer : $\theta_c = \sin^{-1}\left(\frac{n_1}{n_2}\right)$

Here

$$n_1 = 1.45 \text{ এবং } n_2 = 1.50$$

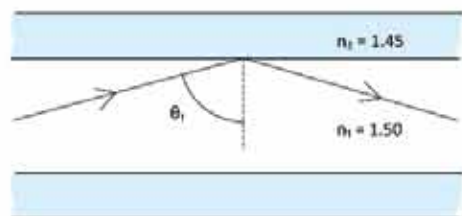

Figure 9.11: Total internal reflection occurs from core to clad in optical fiber

$$\theta_c = \sin^{-1}\left(\frac{1.45}{1.50}\right) = \sin^{-1}(0.97) = 75^\circ$$

Therefore light has to incident at an angle of 75° or more.

9.3.2 Periscope and binocular

There is something called periscope in submarines and it is possible to see above the water surface while under water by periscope. The periscope is made by a prism and its total internal reflection is more effective than a periscope made of ordinary mirrors (Figure 9.12). In order to reduce the length of binoculars, total internal reflection is done using prisms in it.

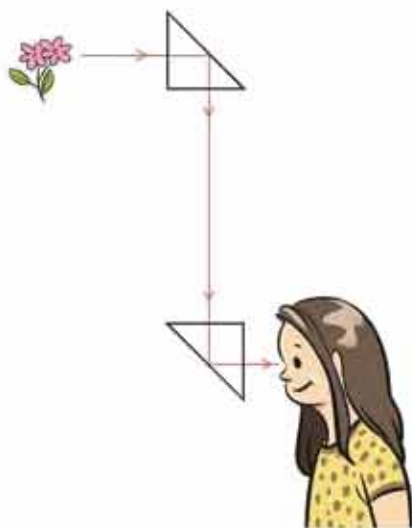

Figure 9.12 : Prism is used instead of mirror in periscope

9.3.3 Prism

If the two surfaces of a transparent medium are not parallel, this is called prism. The light goes out in a direction parallel to the direction in which it enters the transparent medium. Though the direction

remains unchanged, the light ray bends a little bit from the main ray. In the case of prism the direction of light changes (Figure 9.13). While entering the first surface the ray bends toward the normal. The second surface is not parallel, so when going out from this surface the light ray moves away from the normal but cannot move towards the main ray. Though in a prism the direction of light changes, it is important for another reason. After entering the prism, how much the ray of light will deviates from the main direction depends on the refractive index of the prism. We know that the refractive index depends on the wavelength or the color of light. So there is a different refractive index for different colors. Therefore, if there exists different colors in the same ray of light, when passing through a prism the ray of light of each color will change its direction in different angles. Therefore we will see that when coming out from the prism the light is separated into its component colors. This was first shown by Newton.

9.3.4 Lens

A lens is created using the refraction of light. Using lenses, starting from spectacles, sensitive optical instruments like telescopes and microscopes are made. A lenses are also used in video projectors and cameras. In this chapter, we'll broadly discuss about lenses, types of lenses and their properties.

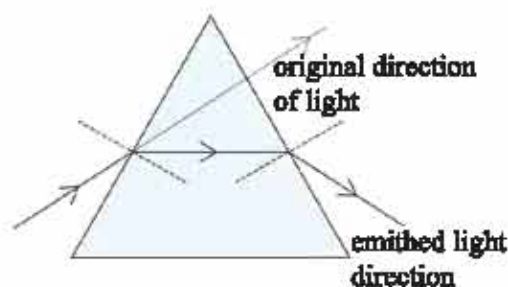

Figure 9.13: In prism rays of light deviate towards the base of the prism.

9.4 Types of lenses

In convex and concave mirrors, we've seen that, when light enters these mirrors, sometimes it focus to a point (converging ray) or sometimes it diverges (diverging ray) and the image is formed. That image is sometimes real and sometimes virtual. Sometimes it is big, sometimes it is small. Using these images in many ways, optical instruments have been developed.

Many types of images are made by convex or concave mirrors which also be made by lenses and they are used in many ways. We have all seen lenses (because the spectacles are actually a kind of lens). Those of you who have used spectacles or have seen others using spectacles have certainly noticed that lens of spectacles can be divided into two types. Small things can be seen bigger with one kind of lens (usually the lenses of spectacles for old people are like this). Again big things can be seen smaller with another kind of lens.

(Usually the lens of spectacles of the young people are like this). The lenses with which small things are seen bigger are called convex or (sometimes) converging lenses. The lenses with which big things are seen smaller are called concave or (sometimes) diverging lens. Mid portion of the lenses with which small things are seen bigger or convex lens is thicker than the edges. And the mid portion of

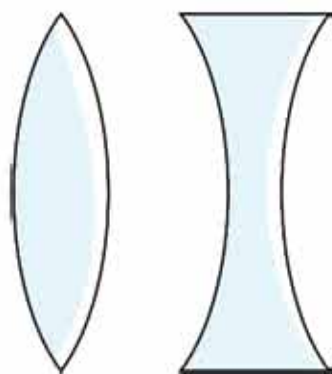

Figure 9.14: Cross section of a convex and a concave lens

the concave lens is thinner than the edges as shown in 9.14. If we see the cross section of the concave or convex lens we can understand that both are bound with two round circles. The radius of these two circles can be different or the same. The centers of these circles are called the centres of curvature. In the picture 9.15, C_1 and C_2 are the centres of curvature.

Different kinds of lenses are used in everyday life or in different subjects of science.

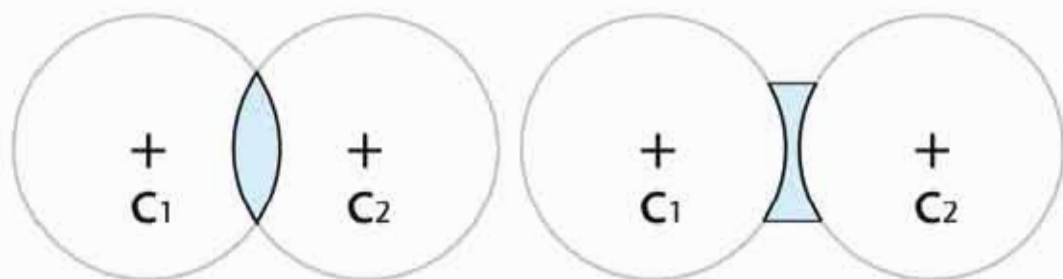

Figure 9.15: Convex and concave lens can be imagined as the part of two circles.

We will keep our discussion limited to thin lenses. Though the difference between thin and thick lenses can be understood by their names, let us explain this more. Looking at the cross section of the lens, we can see that though the lens has a curvature in the surface, at the middle the two surfaces are almost parallel. We know when light passes through a parallel surface it is deviated a little from the main direction due to refraction (Figure 9.16).

As the parallel surface thickens, the rays of light will deviate more. If the parallel surfaces are close to each other, we can say that main rays of light go

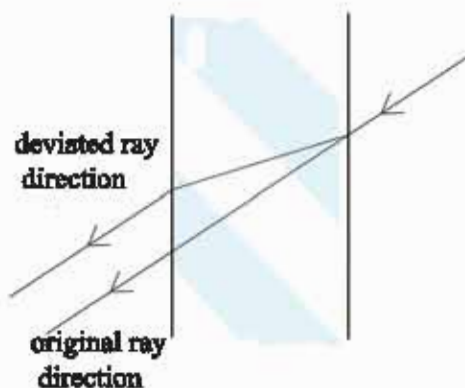

Figure 9.16: When passing through thick glass light rays are deviated from main rays due to refraction.

out roughly in the same direction, there is no deviation .

In the case of those lenses in which light ray passing through it, the direction of the ray remains unchanged is called a thin lens. (Figure 9.17). We can say that the point of the middle of a thin lens through which light rays do not deviate when passing through it is called the center of that lens (Figure 9.17, point O) or the Optical center.

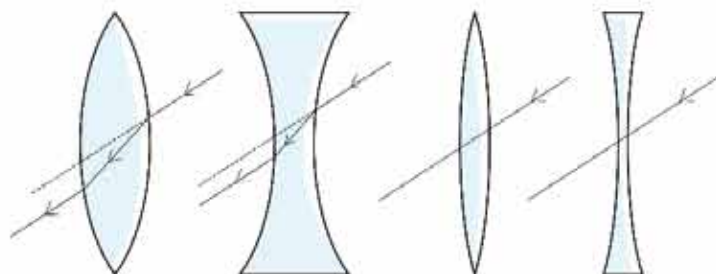

Figure 9.17: When passing through a thick lens rays of light deviate a little; when passing through a thin lens light rays do not change direction.

9.4.1 Concave lens

While discussing about convex and concave mirrors, we first learned about convex mirrors. In the case of lens at first we will discuss concave lens. Because a concave lens forms the image a like a convex mirror.

In the case of a convex mirror we saw that parallel rays diverges in all directions during reflection. In the case of concave lens the same thing occurs. The incident parallel rays on this lens are diverted during refraction. If we extend the refracted rays of light backwards, it would seem that they are spreading out directly from a point.

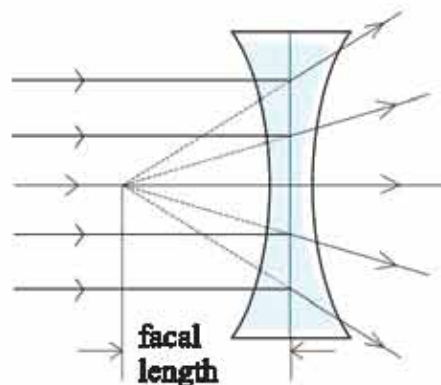

Figure 9.18: Rays of light diverges when passing through a concave lens.

That point is called the focal point and the distance from the focal point and the center of lens is called the focal length. (Figure 9.18)

In case of a convex mirror, light is incident from one side. In the case of a lens, light can be incident on it from both sides. Every lens has a focal length. The focal length of a lens remains the same whichever direction the light is incident on it. If parallel light incidents on this lens, the rays spread out, and appear to diverge from focal point. If the direction of the rays of light is reversed then they go back through the direction they came. So if we can reverse the direction of divergent rays, then they will emerge in parallel and will go in the inverted direction (Figure 9.19).

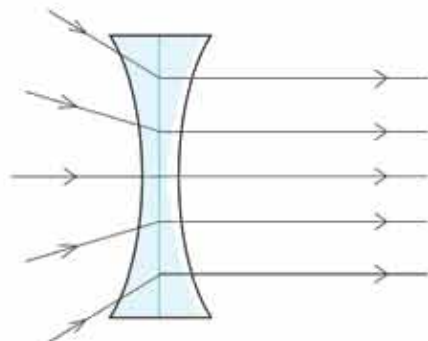

Figure 9.19: While passing through concave lens rays of light converging rays emerge in parallel.

To understand how an image is formed in concave lens, we need to know how light rays are refracted through a concave lens. It depends on the angle with which the light ray is falling. If we know the three special rules of refraction of light, we can explain how the image is formed:

- (i) If the ray of light is centripetal (Figure 9.20, YO or XO ray) it goes straight after refraction.
- (ii) The rays which are parallel with the principle axis, (Figure 9.20 XP) will (PS) appear to diverge from the focal point (F) after refraction.
- (iii) If the direction of the light ray is reversed then it goes back through the way it came. Therefore, if any ray goes (Figure 9.20, SP) towards the focus then it will be refracted in parallel with the principle axis.

Now we can find out how the image of an object will be in a concave lens. Suppose an object XY is kept near a concave lens. (Figure 9.20) To make the analysis easy, we have taken the point Y of that object on the principle axis YR. To find where the image of a point will be formed, at least two rays should be drawn from that point. But we can find the image of Y without drawing two rays. It is possible to draw a ray along the principle axis YR, so we know the image of this point will be formed on this axis. We will get the image of point Y if we

draw a normal on this axis from image of X.

Imagine two rays from point X, one is XP which is incident on the lens in parallel with the axis. This will diverge when emerged and will appear to diverge from the focus, so if a line is drawn from the focus F to P and elongated, then we'll find that ray. Let us draw the second ray from point X towards the center of the lens. According to the rules of thin lenses it will emerge directly along the direction of XT. The point where XT and FS intersect each other is the image X' of X. If we draw a normal from X' on the axis we will get the image X'Y' of XY.

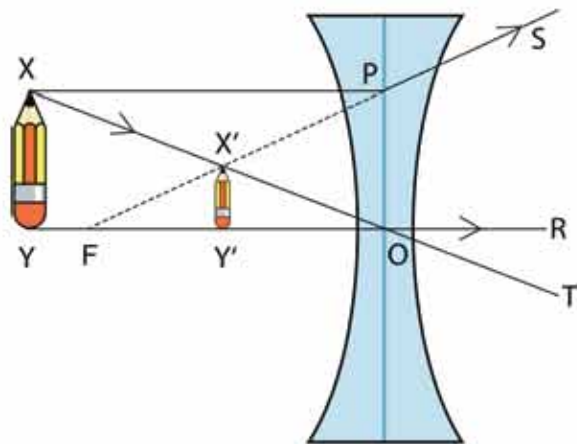

Figure 9.20 : An object looks small in a concave lens

The things which are seen in the case of convex mirror are true in the case of concave lens.

- Its position will be in between the center and focus of the lens.
- It is virtual
- It is erect.
- It is small.

9.4.2 Convex Lens

The images in convex lens are amazing. The image which we got from a concave mirror, is the same as the images in a convex lens. We have seen in the case of a convex mirror that if a parallel ray falls on it, then it converges at the focal point. The same thing happens in the case of a convex lens, if parallel rays fall on it, they will meet at the focal point (Figure 9.21) and again spread out.

Therefore, using previous logic we can say that if light diverges from a point and the source of the divergent light (Figure 9.22) is placed in the focal point of a lens, then while passing through the lens, rays of light will emerge as parallel

rays (in the case of light, it is always true that if the light goes from A to B and if the direction of the ray is changed, it will always go from B to A). Now let us find the position of the image for different positions of an object .

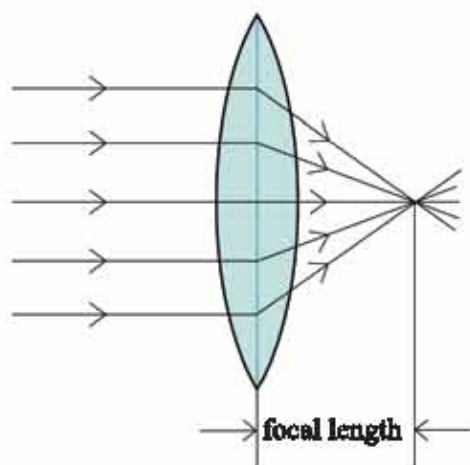

Figure 9.21: When passing through a convex lens, parallel rays of light converge at the focal point.

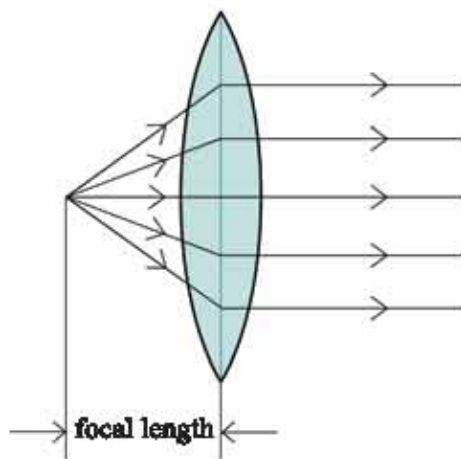

Figure 9.22: If the light spot is kept at the focal point, the converging lens makes the rays parallel.

Before starting, let us learn how light ray refracts in a convex lens. If we know three special rules of the refraction of light through convex lens, we can describe how the image is formed .

- (i) If the rays of light is centripetal (Figure 9.23, YO or XO ray) it goes straight after refraction.
- (ii) The rays which are parallel with the principle axis, (Figure 9.23, XO) will (CT) pass through focal point (F) after refraction.
- (iii) If the direction of the light ray is reversed then it goes back the way it came. Therefore, if any ray goes (Figure 9.23, TC) through the focus then it will be refracted in parallel (CX)

Now we can form the image for a convex lens.

The distance less than Focal length

Imagine an object XY , which is kept between the lens and the focal point (Figure 9.23). By the same logic described before, we can say that the image of point Y will be formed on YOF line. If a perpendicular is drawn from the image of X on this axis, we'll get the position of the image of Y .

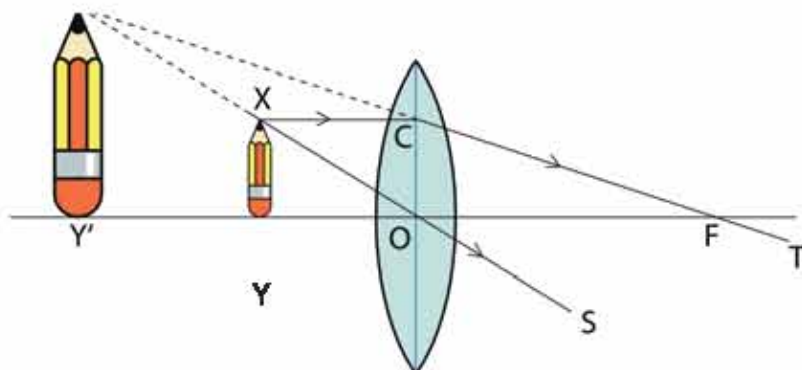

Figure 9.23: A bigger image is seen in a convex lens if the object is placed within the focal length.

Now let's draw two rays from the point X . XC line, which is parallel with the axis will go towards the direction of T through the focal point F . If a ray from point X is drawn through the center point of the lens, it will go straight along XO towards S . CFT and XOS will not meet going forward, which means there is no chance of forming a real image. If the two lines are extended backward, they will meet at point X' , which is the image of X .

The normal which is drawn from the point X' on the line YF touches YF at the point Y' . This is the image of point Y .

The closer the XY object is to the lens, the bigger the image will be. The closer the object is to the focal point F , the bigger the image will be. When the object will be exactly on point F , the size of the image will be infinite. Now we can say, if an object is kept between the center of the lens and the focal point of a convex lens, the image of the object:

- Will be formed in the same direction as the object.
- Will be virtual.
- Will be erect and
- Will be big.

Outside the focal length

Now let's see what happens if the object is kept outside the focal length. Three different things can happen in this case, like in a concave mirror. (i) The object is outside the focal length but inside twice of the focal length. (ii) The object is outside twice of the focal length and (iii) The object is exactly on the twice of the focal length. Let's examine this one by one.

(i) First, the object will be kept outside the focal length but inside twice of the focal length. In Figure 9.24, the image of the point Y of the object XY will be on the YO line. So, we find the image of the point X, as before. The ray from point X which is parallel to the axis will go through the focal point F. Another ray will pass through the center point along line XO. The point X' , where the two lines meet, is the image of point X. If a normal is drawn from X' to the axis YO, then the point will be the position of the image of the point Y. Therefore, for the image of XY, we can say :

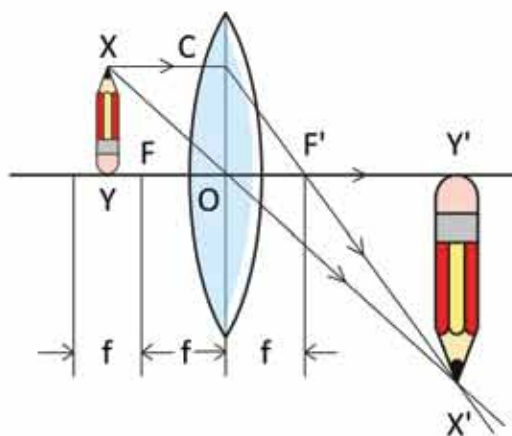

Figure 9.24: If the object is at the outside the focal length but inside the twice of the focal length, the real, inverted and bigger image is formed.

- (a) The position of the image will be outside twice of the focal length
- (b) It is real
- (c) It is inverted
- (d) It is bigger than the size of the object

(ii) Now let's see what will happen if the object is kept outside twice of the focal length. It is seen that if the object XY is kept at exactly twice of the focal length (Figure 9.25), then the size of the image will be same as the object XY and the position of the object will be at the same distance from the center of the lens. The closer the object will be brought to the focal point, the further away the

image will be formed, and the size of it will start to increase. As the ray of light actually goes through the image, it is a real image and it is seen clearly in the picture that the image is inverted i.e:

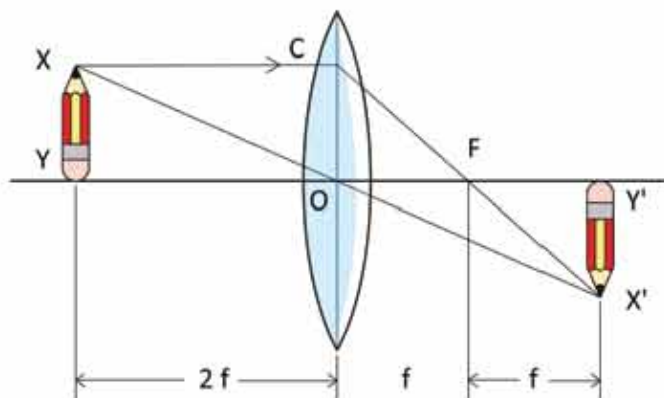

Figure 9.25: If the object is placed at a distance twice the focal length, the size of the image will be same as the object.

- (a) The position of the image will be on the twice of the focal length
- (b) It is real
- (c) It is inverted
- (d) It is the same size as the object

(iii) Now let's see if the object is placed outside at a distance twice of the focal length. Where and what kind of image of the object is formed?

The process of drawing this image is the same as the previous one but (Figure 9.26) the object is to be drawn outside twice of the focal length. We know that if the object is kept on twice of focal length, then a same size image is formed at the same distance.

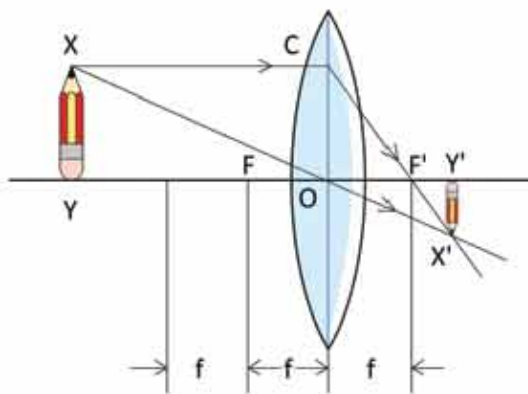

Figure 9.26: If the object is placed at outer side of the twice of the focal length then small, inverted, real image is formed.

As the object is gradually moved away, the image becomes smaller and starts to come closer the focal point. If the object is brought to infinity, the image of it will be formed exactly on the focal point. Therefore, if an object is kept at the distance outside twice of the focal length, then the image is :

- (a) Between the focal length and twice of the focal length
- (b) Real
- (c) Inverted
- (d) Small



Example

Question: If an object is kept outside twice of its focal length, then a real image of the object is formed. If the object is kept at the position of the image, then where will the image be formed?

Answer: If the direction of the light ray is changed, then one is converted to another.



Do Yourself

If the light from a distant object falls on a lens, then it forms its image on the focal point of the lens. Using this process you can find the focal length of a convex lens. In order to do it you should move the lens forward and backward until a distinct image is formed on the wall. When the image is distinct, then measure the distance from the lens to the wall. This is the focal length of this lens.

If you don't have any convex lens, you can do the experiment using the glass of spectacle. Often the spectacles of elderly people are made with convex lenses. If closer things are seen bigger by the glass of the spectacle, then you'll understand that it is a convex lens.

9.4.3 Power of Lens

The most familiar use of lens is in spectacles. If you have experimented with the lenses of spectacles of many people, you have seen that many of their spectacles are made of convex lens, and many are made of concave lens. Usually we explain the lenses by discussing power.

You have certainly heard people say that the power of a lens of somebody is high. What do we mean by the word power?

The conception of power comes from the matter of seeing big and small using a lens. If we place a body in front of two different lenses at the same distance, and the object looks bigger in one lens than in another lens, then we say the power of the lens is higher in which the object looks bigger. If you think about it you will see that the smaller the focal length of the lens, the object is seen bigger (Figure 9.27). Therefore the power of a lens P is inversely proportional to the focal length. If the focal length is f in meters then unit of power P is the diopter. If the power of the glass is 2.5 (Nobody uses diopter in general conversation). Then the focal length of this glass will be

$$f = \frac{1}{P} = \frac{1}{2.5} \text{ m} = 0.4 \text{ m (the unit is in meter)}$$

Power is not only used only for convex lens to show bigger objects. In the case of concave lens the same power is used to show smaller images. In the concave lens in which the object is seen as much as smaller, the power will be greater or the focal length will be smaller. In the case of a convex lens the power is positive and in the case of a concave lens the power is negative.

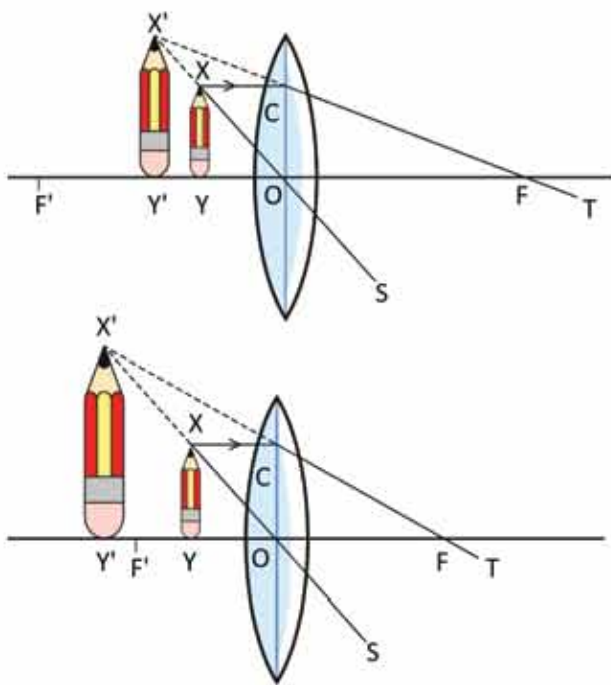

Figure 9.27 : The lens which have as much as smaller the focal length, the object is seen to be bigger

9.5 Function of the Eye

9.5.1 How we can see

The eye consists of the retina, eye lens, aqueous humour and vitreous humour, cornea (Figure 9.28). You have got an idea about how lenses works. So you certainly have understood the eye lens works like a convex lens. We saw earlier that a convex or converging lens always forms an inverted image. To take a picture in a camera the image is formed in this way.

Whenever we have some thing in front of us, then the light from that thing refracts by this lens and forms an inverted image on the retina. If there is light on the retina, the light sensitive small cells connected with the nerve receives that light and turns it into electrical signals. The nerve sends this electrical signal to the brain through the optic nerve immediately. The brain turns upright the inverted image formed on the retina so we see the object

as it is. The iris increases or decreases light inside the eye. If you shine light from a torch on the eye, the iris is compressed and makes the pupil small.

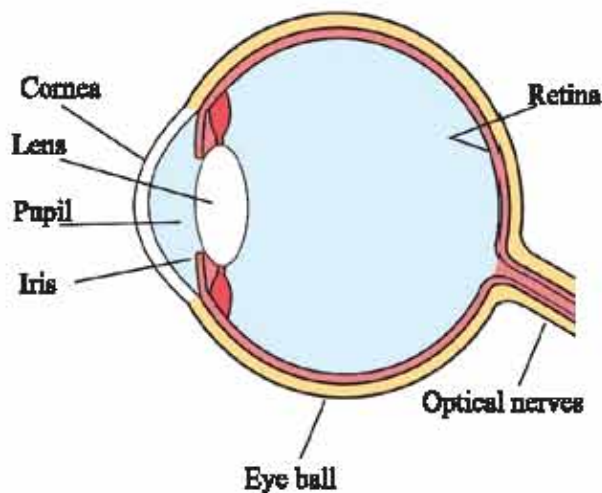

Figure 9.28 : Different parts of eye

9.5.2 Accommodation of eye

We place an object close to our eyes to see it clearly. You surely have noticed that if we get the object too close to the eyes it starts to become obscure again. The human eye is wonderful, muscles are attached to it and these muscles push the lens and make it thick or thin and thus can increase or decrease the focal length of the eye lens.

So, to form a distinct image on retina, the lens is always increasing or decreasing its focal length. You can do this experiment easily by yourself. Keep your finger in front of your eye and try to see your finger and other things which are situated far from

your eye at the same time. When you'll see your finger distinctly, then the object which is far from your eye will be fuzzy. Again when you'll see the object distinctly, your finger will be fuzzy. The capacity of the eyes to change their focal length to see objects of any distance is called the accommodation power of eyes.

9.5.3 Least distance of distinct vision

If the object comes too close to the eyes from a fixed distance, the object is not seen distinctly. The nearest point at which the eyes can see distinctly is called the least point of distinct vision, and the distance from the eye to that point is called the least distance of distinct vision. This distance changes with a person's age. This distance for the children is near about 5 cm and for adult it can be upto 25 cm. The point of maximum distance for which an eye can see an object distinctly is called the farthest point of distinct vision. The far point for a normal eye is at infinity, so we can see the stars of several light-years away.

9.5.4 Defects of vision and it's remedy

We know a healthy and normal eye can see an object clearly between the 'near point' and the farthest point (infinity). This is the normal power of vision of eyes. If this normal power of vision is obstructed, then it is a defect of the eye.

Though there are many defects of eye, we'll discuss two principle defects:

- (a) Myopia or Nearsightedness
- (b) Hypermetropia or Farsightedness

Myopia or Nearsightedness

When an eye can see near objects but can't see distant objects, then this defect of eye is called Nearsightedness. Farthest point of these kinds of eyes are near, instead of being at infinity and the object is seen clearer if it is brought inside the least distance of distinct vision. This defect happens for two reasons :

- (i) If the power of the lens increases or the focal length decreases and
- (ii) If the radius of the eye-ball increases for any reason.

For this reason after refraction, the rays of light from a distant object forms the image in front of the retina (F) instead of forming it on the retina (Figure 9.29a). The eye then can't see the object clearly.

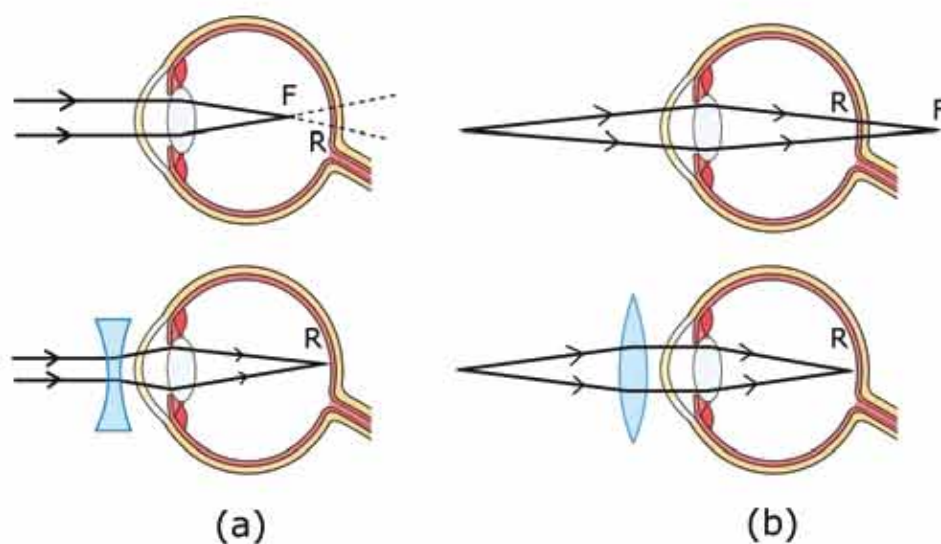

Figure 9.29: A Lens is used to solve the problem when the eye lens can not form the image in the right place.

Remedy

To rectify this defect, a spectacle of a concave lens is used. The diverging action of this lens of the spectacle is opposite to the converging action of the convex lens. So, as the focal length of the eye increases, the image will be formed further back. i.e the parallel rays from an object at infinity, while passing through the concave lens of the spectacle diverges (Figure 9.29a) as needed and falls on the eye lens.

This divergent ray refracts through the eye lens and form a clear image right on the retina.

Hypermetropia or Farsightedness

When an eye can see distant objects but cannot see near objects then this defect is called Hypermetropia. Generally this defect is seen in older persons. This defect occurs because of the following two reasons:

- (i) if the power of convergence of the eye lens decreases or the focal length increases.
- (ii) if the radius of the eye ball decreases for any reason.

For this reason light rays coming from a distant object can make an image on the retina but rays coming from the near point, after refraction through the eye lens, converge to a point (F) behind the retina (Figure 9.29 (b)). For this reason the eye cannot see the near object clearly.

Remedy

A spectacle of a convex lens is used to rectify this defect. So rays coming from the near object (Figure 9 .29 b) will refract twice, once through the lens of spectacles, and another time through eye lens. The focal length will decrease and the rays will converge as needed to form an image on the retina (R).

9.5.5 Eye and the properties of vision of eye.

The eye is a wonderful thing, it has many types of properties. Some properties of eye and vision the are discussed here.

(a) The image of an object is formed on the retina if the object is placed in front of eye, and we can see the object. If the object is removed from eye sight, the sense of vision does not go away immediately, it remains for about 0.03 second. This period is called persistence of vision. Due to the persistence of vision ,we can watch films and videos .

(b) Our two eyes are both in front (Not on two side as like as birds, but the matter of owls is different; the eyes of owls are in front like in human beings) so we see two images at a time . Our brain superimposes these two image and gives us the sensation of distance.



Do Yourself

Because we have two eyes, when we look anywhere, we get the perception of distance. This is called binocular vision. If we use one eye then we do not get the perception of distance. To examine the matter, try to pass thread through a needle hole with one eye closed. You'll see how hard it is. Before inserting the thread, move the hands with which thread and the needle is held forward and backward with the eye closed.



Figure 9.30: The presence of blind spot can be find out by this picture

(c) We know that though an inverted image falls on our retina, we get the perception of viewing the object upright because the perception of vision does not come from eyes, it comes from the brain. The signal of light from the image which is formed on the retina goes to the brain through optic nerve and, analyzing that, the brain gives us the perception of vision.



Do Yourself

The part of the retina where the optic nerve is connected does not make the perception of vision. So, it is called the blind spot. Do you want to test this? Closing your left eye, look at the cross sign at the left side of the Figure 9.30. Move your head down to the picture. When the image of the black circle at the right side will form at the blind spot, the connecting part of the optic nerve, then suddenly it will disappear.

9.6 Perceptions of Colored Objects

When we see an object, the light comes and fall on our eyes after reflection from the object. The cornea and lens of eyes together makes a perfect image on the retina. There are two types of light sensitive cells in our retina, rods, and cones. The rod cells are highly sensitive and can work in less light, but they can't identify the colors. For this, we can see indistinctly in the moon's gentle light but we cannot see colors. If the sharpness of the light is high, then the cones of the retina can work. These cones are colour sensitive.

If you can see colour pictures in television, computer's monitor or in books, accurately then you'll see the colors come from red, green and blue colored narrow points . That is, all other colors can be made by mixing the intensity of these three colors.



Do Yourself

Put a drop of water on the screen of mobile, television or laptop. This will then work like a convex lens. You will be able to see the pixels of the screen. Look at the colors of the pixels by which different colors are made. What is the color of the pixels for yellow?



Do Yourself

Look at Figure 9.31, which is drawn by opposite color, in bright light at least for one minute. Don't move your eyes. Then look at the gray colored rectangular shaped place. There, you'll see the correctly colored picture. The color sensitive cells of your eyes get tired looking at a color for a long time. When you look at the colorless gray area, then the cells which are not used or not tired remain more active. Then, the opposite color sensitive cells of the retina shows that color, so this image is seen.



Figure : 9.31: Picture drowned in inverse color.



Group work

Objective : Determination of the relation between the power of spectacles and the least distance of distinct vision of different persons.

Aparatus: Book printed in small font size, measuring tape or ruler.

Procedure : (a) Select 10 persons from your teachers, classmates, parents, or siblings who use spectacles with positive or negative power, as well as people who do not use spectacles.

(b) Ask them to read books or newspapers and measure the distance at which they can read comfortably. This is the least distance of distinct vision.

(c) For those who use spectacles, ask them to read books or newspapers without spectacles and measure the least distance of distinct vision .

(d) Write the name of persons, estimated age, and power of spectacles of those who use spectacles and the least distance of distinct vision with and without spectacle in the table below.

Explain the difference in the least distance of distinct vision due to the positive and negative power of the spectacles.

Observation table

Name	Estimated Age	Power of spectacle of spectacle user	Least distance of distinct vision with spectacle	Least distance of distinct vision without spectacle

**Exercise****General questions**

1. The lens of the eye makes inverted image on retina. Why do we not see everything inverted?
2. What is an important difference between eye and camera.
3. The velocity of light in a denser medium is less. Is there anything which can go with the velocity greater than the velocity of light?
4. At noon why is rainbow not seen ?
5. Drops of water can work like a lens. What is focal length of this lens ?

**Mathematical questions**

Figure 9.32: Total reflection angle will be changed if liquid drops of different refractive index are placed on the point of incidence.

1. If a ray of light passes through glass having shape shown in Figure 9.32, then the critical angle of total internal reflection 65° is found. Due to a drop of liquid at the point of incidence, total internal reflection happened at angle 75° . What is the refractive index of the liquid.

2. The focal length of a convex lens made of glass is 10 cm. If a lens of exactly the same size is made of diamond then what will be its focal length?

3. Draw the rays for object XY and show the position of the image as accurately as possible (Figure 9.33).

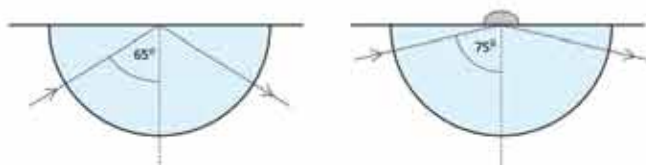
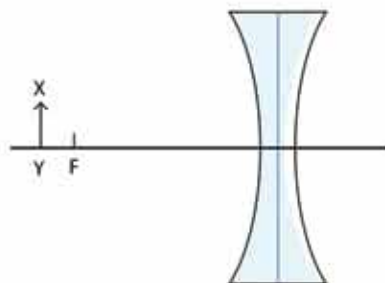

Figure 9.33: An object which is kept at a point outside of the focal length.

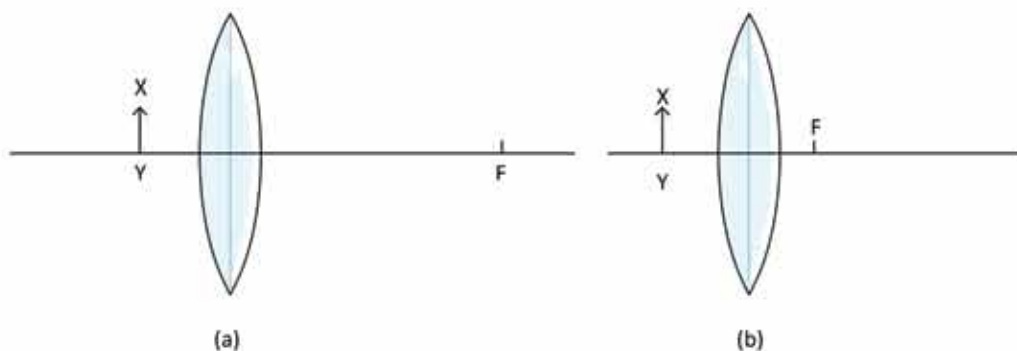

Figure 9.34: (a) An object kept inside of the focal length of a convex lens (b) an object kept outside of the focal length of a convex lens.

4. Draw the rays for object XY and show the position of the image as accurately as possible (figure 9.34 a).

5. Draw the rays for object XY and show the position of the image as accurately as possible (figure 9.34 b).



Multiple choice questions

Choose the correct answer.

1. Where will the image of an object be when it is placed in a denser medium and looked at from a rarer medium?

- a) raised upward b) gone downward
c) remained at the same place d) moved aside

Answer the questions 2 & 3 from Figure 9.35

2. What is the angle of refraction here?

- a) 0° b) 90°
c) 180° d) 45°

3. What will happen if the angle of incidence is bigger?

- a) Total internal refraction
b) Total internal reflection
c) Refraction
d) Reflection

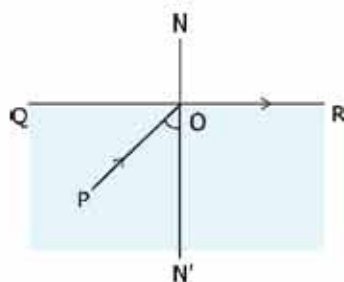

Figure 9.35

4. The ray diagram usually used to draw the image for a convex lens is –

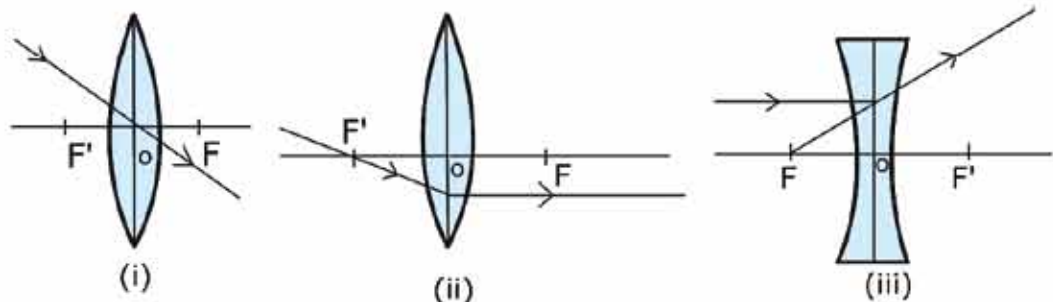

Figure 9.36

- (a) i (b) ii
(c) i & ii (d) i, ii & iii

5. Which is the unit of power of a lens?
- a) Diopetre b) Watt
c) Horsepower d) kilo-Watt Hour



Creative questions

1. Sheuli, a student of Class10, cannot see the written words on the blackboard. She consults with the doctor and the doctor advised her to use a lens of power $-2D$ as spectacles.
- (a) What is a lens?
(b) How do you identify a lens without touching it?
(c) What is the focal length of Sheuli's spectacles?
(d) Explain why it is logical for Sheuli to use a spectacle of (-)ve power.
2. Topu discovered that holding his magnifying glass in the sun, the paper at 6 cm from glass starts burning. He tried to see the image of a 2 cm high eraser keeping it 8 cm away from the glass. He also discovered that to see the image without spectacles he has to go backward from the position of the eye where he can see the image with spectacles.
- (a) Write down the classification of lenses.
(b) What does it mean to say that the refractive index of glass with respect to air is 1.11?
(c) What type of image of the eraser will be formed with its position ? Draw the ray diagram.
(d) Explain the problem of Topu's eye.

Chapter Ten

Static Electricity



If you comb your hair in winter and then hold the comb near some small pieces of paper, you will notice that the pieces jump towards the comb. Again during storm, flashes of lightning and thunder bolts rumble and shake up the whole area. Static electricity is responsible in both the cases. Everything around us consists of molecules and atoms the nucleus is the center of an atom and the electrons revolve around the nucleus. An electron is negatively charged and a nucleus is positively charge. If one or more electrons can be separated in any way, static electricity is produced. We will discuss the various processes of static electricity in this chapter. We will moreover know how force acts between two charges when they are kept near to each other.



By the end of this chapter we will be able to-

- explain the basic causes of production of charge on the basis of the structure of atoms.
- explain the causes of production of charges by induction and friction.
- detect the nature of the charge by an electroscope.
- measure the electric force by applying Coulomb's law.
- explain the causes of production of an electric field.
- explain the direction of electric lines of force that can represent the direction of the electric field.
- explain the electric potential.
- explain the function of capacitors to preserve electrical energy.
- explain the usage of static electricity.
- explain the strategy to keep safe from the risk of static electricity.

10.1 Charge

If you comb your hair in winter and then hold the comb near some small pieces of paper, you will notice that the pieces jump towards the comb. In cold countries during winter air is very dry. When babies crawl on carpet, their hair seems to stand straight and it seems one hair is pushing the other. All of you have seen thunder bolts during stormy night and observed how flashes of lightning comes towards the earth.

In the attraction of paper, repulsion of hair or thunder bolt- the basic thing behind these three phenomena is charge. To know what charge is and why charges attract or repulse or create thunder bolts, we have to understand the basics, we have to know how atoms and molecules are formed.

We all know everything is made of an atom and molecule. There are 118 atoms in this world, among which 83 are stable, only with these atoms millions of different molecules are formed. Water is made of two hydrogen and a oxygen atom, a sodium atom and a chlorine atom forms table salt, a carbon with four hydrogen atoms form the cooking gas, etc. (You need not be surprised, there are only 50 letters in Bengali, with these alphabets thousands of words are built!)

Atom is the building block of everything. Nucleus is the center of an atom and electrons revolve around the nucleus. The nucleus consists of a proton and a neutron. A proton is positively charged while a neutron is chargeless and an electron is negatively charged. The charge of a proton and electron is equal but opposite and the magnitude of this charge is 1.6×10^{-19} coulomb. In an atom generally there are the same number of electrons and protons and so an atom is charge neutral. Hydrogen is the simplest atom. The nucleus of hydrogen atom consists of only one proton and only one electron is revolving around it. The next atom is helium which consists of two protons in the nucleus (and two chargeless neutron) and two electrons outside the nucleus. In this way larger atoms are formed. Excluding hydrogen atom, we can say the number of protons that a nucleus there is at least the same number or generally more than this number of neutrons present.

Electrons outside the nucleus do not revolve in the same orbit. As shown in figure 10.01, electrons on filling up one orbit go to the next orbit. Electrons in orbits close to the nucleus are strongly bound, but for some atoms electrons in the outer orbits can be separated with a little effort. Ionization is a process of removing the electrons.

Normally atoms are charge neutral and that means there are an equal number of electrons and protons in an atom. But if an electron is removed from the outermost orbit, then the number of protons is more than the electrons and the atom is not electrically neutral anymore, the amount of positive charge within it increases. If one electron is removed, one positive charge is developed in the atom, if two electrons are removed, two positive charges are developed. We then say that the atom has been ionized or charged. As an atom is positively ionized, it can also be negatively ionized or charged. That is, when one or more isolated electrons are attached to an atom, then the total charge of the atom is negative.

The electrons of an atom revolve around its orbit; there are certain rules about how the electrons will be distributed in the orbits. You have learnt this elaborately in your chemistry book. So we will not go deeper. You know sometimes in the last orbit, there are one or two electrons that are nearly free; in such materials electrons can make movement very easily within the materials. We call these materials

electric conductors. Again, there are some materials within which there are no electrons that can move freely, in these materials electrons are tightly bound. These are called nonconductors. Metals like gold, silver, copper etc. are good conductors of electricity. Wood, plastic, glass, rubber etc. are nonconductors of electricity.

If we have understood the topics explained so far about the structure of atoms, the next topics following static electricity will be very easy to understand.

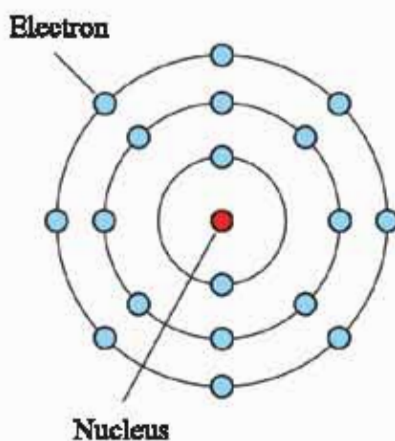

Figure 10.01: An atom of argon. Electrons fill up one orbit and then other orbits

10.2 Static Electricity by Friction

If a glass rod is rubbed by a piece of silk, (Figure 10.02) electrons start to move from the glass to the silk. So the glass rod is positively charged and the silk negatively. This happens because silk has more affinity for electrons than the glass. Again if a plastic is rubbed using a flannel (or wool), electrons will move to plastic from the flannel. Because plastic has more affinity for electrons than the flannel.

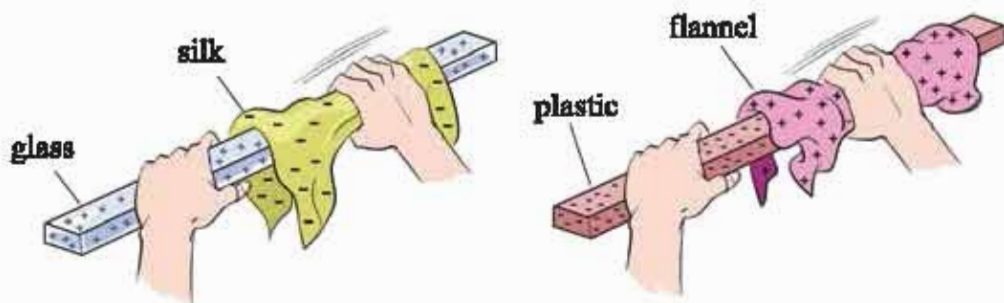

Figure 10.02: If glass is rubbed with silk and a plastic is rubbed with flannel positive and negative charges can be produced,

Now we can do an experiment. Suppose, using glass and silk we have positively charged two pieces of glass. If we carefully hang one piece of glass with insulator silk and then bring the other close to it then we will notice that the glass that is hanging is going away due to repulsion (Figure 10.03).

Similarly if we charge negatively two pieces of plastic and hang one of them with silk thread and bring the other near to it, we will see the same result, one is repelling the other. Now if we bring the positively charged glass rod near to the negatively charged plastic rod, then we will see, they will attract one another.

When we learnt gravitational force, there was only one type of mass, so only one type of force, and it was attraction. Now we see there are two types of charges and so forces are of two types, sometimes attractive, and sometimes repulsive.

If we have done the experiment properly, we will find that similar charges repulse each other and opposite charges attract each other.

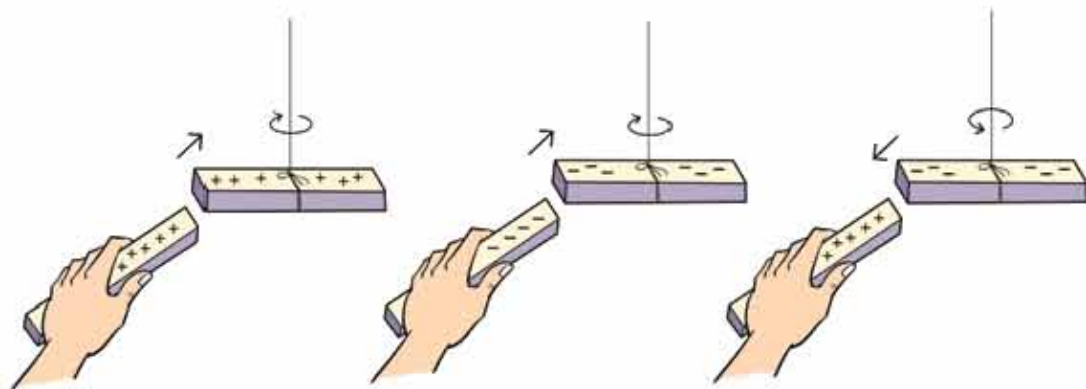

Figure 10.03: Like charges repulse each other and unlike charges attract each other.

10.3 Electrical Induction

At the beginning of this chapter it was said that if you comb your hair and then hold the comb near some small pieces of paper, you will notice that the pieces of paper jump towards the comb. The comb is attracting the pieces of paper. We know that negative charge has been gathered in the comb and due to this reason the comb is attracting the pieces of paper. But there is a slight complexity. We know opposite charges attract each other, so to attract the pieces of paper opposite charge of the comb has to be created in the paper. Since we know the pieces of paper have no charge, then why is the comb attracting them?

This happens due to a process called electric induction. If charge is accumulated in glass or plastic and brought near a neutral body, then charge will be produced in the neutral body. To explain it, a metal sphere is shown in Figure 10.04 and kept on a non-conducting stand. Now if positive charge is accumulated in a glass rod by rubbing it carefully with silk, and this is brought near the sphere, negative charges of the sphere will come closer due to attraction and positive charges will move away towards the back portion of the sphere. Now the glass rod is positively charged and the part of the sphere near the glass rod is negatively charged, so they will attract each other.

Now we will understand the phenomenon of attraction of paper by the comb. When a negatively charged comb is brought near the pieces of paper, then the

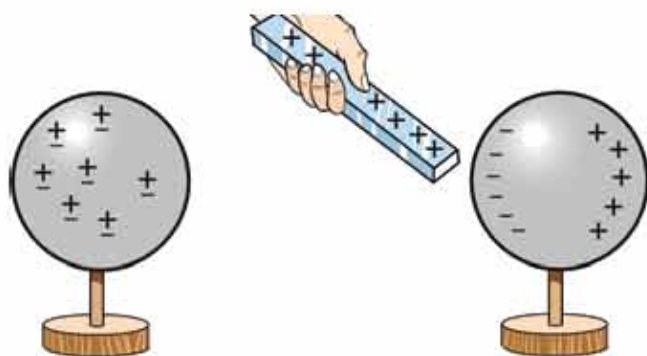

Figure 10.04: If a charged body is brought near to a chargeless body, opposite charge is induced.

part of the paper closer to the comb is induced with a positive charge, while negative charge is induced in the farther parts. The positively charged part of the paper is attracted by the comb and the negatively charged part of the paper is repulsed by the comb. But as the positively charged part is closer to the comb, the attraction is more than the repulsion. As a result, the pieces of paper jump towards the comb, being attracted by the comb. (Figure 10.05)

Another thing happens then which you may have noticed yourselves. Pieces of paper which jump to the comb and attach to the comb almost immediately fall away.

You may understand the reason of this too. If the piece of paper gets attached to the comb due to attraction, then it does not stay induced anymore. It itself becomes accumulated with negative charge by obtaining negative charge from the comb. As a result it gets repulsed by the comb and falls down. You can do the experiment.



Figure 10.05: During winter, combing hair and the comb is held near the pieces of paper, they feel attraction.

If water vapor is present in the air, the accumulated charge gets lost quickly. As a result, these experiments of static electricity work well in winter.



Example

Question: Suppose there are two metal spheres. Is it possible to create two types of charge in the two spheres with a positively charged glass rod?

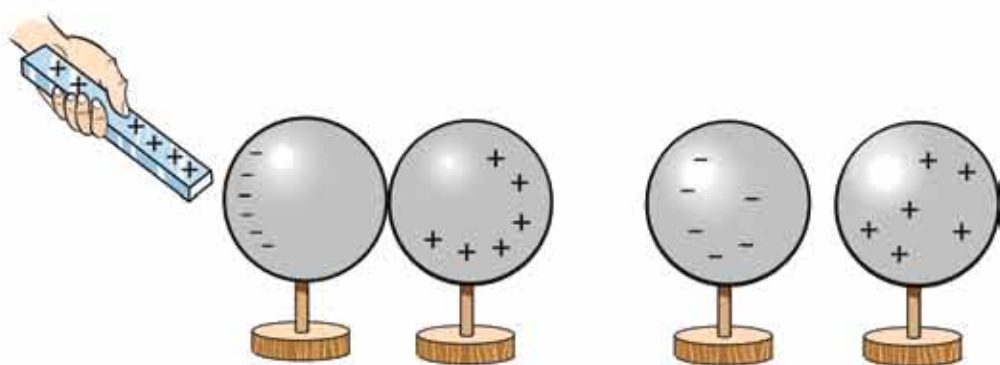

Figure 10.06: It is possible to induce different charges in two spheres in contact.

Answer: As shown in Figure 10.06, it is possible to induce different charges in two spheres and separate them.

We have talked about three different phenomena at the beginning of this chapter. You have understood by now why they happen.

The event of the comb has been explained. The crawling of the little baby is also easy to understand. Due to friction with the carpet, charge accumulates in its body and spreads to the hair also. All hairs have same charge. We know similar charge repulses, so each hair repulses each other and becomes straightened. Now we can explain the event of the thunderbolt too. Due to friction among clouds, charge gets separated. When a large amount of charge is accumulated in the clouds, it creates induction of opposite charge below. Sometimes that is so large in amount, it becomes connected with the clouds by piercing the air. We call this lightning. (Figure 10.07).

10.3.1 Electroscope

An electroscope is a wonderful equipment for test of static electricity. The equipment is very simple. To determine the presence of charge, it contains two light leaves of gold, aluminum or some other metal. These two leaves are connected to a metal disc by a highly conducting rod. The whole setup is kept inside a glass bottle with a nonconducting stopper so that it can be seen from outside, but air or anything else cannot touch the light metal leaves.



Figure 10.07: When a large amount of charge comes down to ground from clouds, we call it lightning.

Charging the electroscope

If a glass rod is rubbed by silk, positive charge is accumulated in the rod. Now if the glass rod touches the metal disc of the electroscope, some charge will immediately go to the disc. As the disc is connected with the metal rod and the leaves, the charge will spread everywhere. When similar charges appear in the gold leaves, the leaves will repulse each other and create a gap between them.



Similarly, if a comb is rubbed with flannel, negative charge will accumulate in the comb. Now if this comb touches the disc, negative charge will spread up to the gold leaves and they will repulse each other and create a gap.

Determining the Nature of Charge

If charge is accumulated in an object, we can determine whether it is positive or negative using an electroscope. At first, we have to give some known charge to the disc of the electroscope. If we create a positive charge in the glass rod by

rubbing it with silk and then touch it to the disc, the reduction of gap between the leaves will indicate the electroscope has negative charge. If the gap increases, then it will indicate the presence of positive charge.

Induction of Charge

We can determine if an object contains charge without touching the disc. Let us imagine, a positively charged rod is brought near the disc. Then the disc will have negative charge due to induction (Figure 10.08). To make induction of negative charges, negative charge from other parts of the electroscope will have to come in the disc and as a result positive charge will be created in the gold leaves too. This positive charge will push gold leaves apart.

Instead of bringing a positively charged object, if we bring a negatively charged object, then there will be gap too between the gold plates. This time it will be due to accumulation of negative charges there.

10.4 Electric Force

We have seen earlier that opposite charges attract each other and similar charges repel each other. But we do not know yet how attraction or repulsion works. To know this, we need to look at Coulomb's law. Coulomb determined how much force works between two charges. We have already seen such a law, Newton's gravitational force law, which is as follows:

$$F = G \frac{m_1 m_2}{r^2}$$

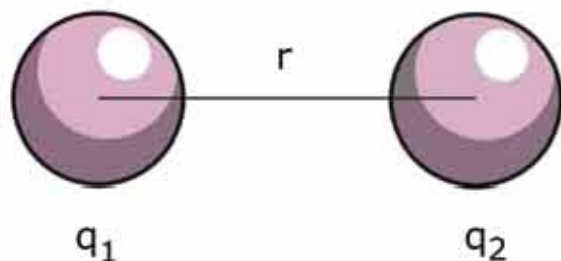

Figure 10.09: The force F acting between two charges q_1 and q_2 can either be attractive or repulsive.

The interesting thing is, if mass m_1 and m_2 is replaced by q_1 and q_2 , we get Coulomb's law. G was the constant for gravitational force, now we will use the constant k . This is the difference. That is, if two charges q_1 and q_2 are placed at a distance r , the force (Figure 10.09) working between them will be,

$$F = k \frac{q_1 q_2}{r^2}$$

Here the unit of the two charges q_1 and q_2 is C and of distance (or r) is m , so we may say, the unit of k will be Nm^2/C^2 , so that the unit of F becomes N .

The value of k :

$$k = 9 \times 10^9 \text{ Nm}^2/\text{C}^2$$

Coulomb is the unit of charge. We will see in the next chapter that the flow of charge is electricity or current, and the unit of current is ampere. If one ampere current flows for one second, the amount of charge that flows is called one coulomb (C).

But, the authentic way to understand the coulomb is to understand the amount of charge of an electron or proton. Its amount is:

$$\text{Charge of electron : } -1.6 \times 10^{-19} \text{ C}$$

$$\text{Charge of proton : } +1.6 \times 10^{-19} \text{ C}$$

You can see, if q_1 and q_2 both are positive or negative, then the value of F is positive and they will repel one another. If one charge is positive and the other is negative, then the value of F will be negative, which means the direction of the force is changed, that is, the charges will attract one another. We have seen this earlier and now the formula shows this too.



Example

Question: A $+1 \text{ C}$ charge and a -1 C charge are placed at a distance of 10 cm . How much force is acting between them?

Answer: Two opposite charges will attract each other. The force acting between them: (Figure 10.10 a)

$$F = k \frac{q_1 q_2}{r^2}$$

Here,

$$q_1 = 1 \text{ C}$$

$$q_2 = -1 \text{ C}$$

$$r = 10 \text{ cm} = 0.10 \text{ m}$$

$$k = 9 \times 10^9 \text{ Nm}^2/\text{C}^2$$

$$\text{So, } F = \frac{9 \times 10^9 \times 1 \times (-1)}{(0.10)^2} \text{ N} = -9 \times 10^{11} \text{ N}$$

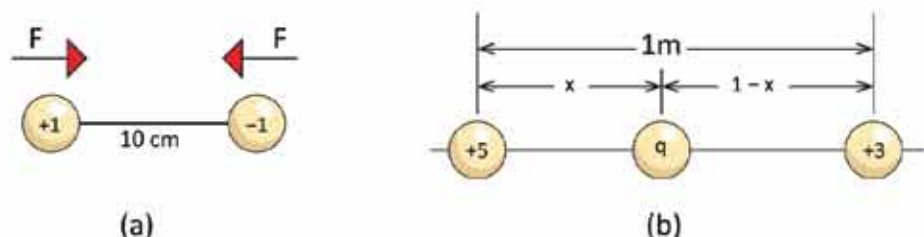

Figure 10.10 : (a) Distance between +1C and -1C is 10cm (b) Distance between +5C and +3C is 1m.

Question: Two charges of +5 C and +3 C are placed at a distance of 1 m. Now a third charge +q is placed in between them, where will it not feel any force. (Figure 10.10 b).

Answer: The +5 C charge will repel +q charge towards the right and the +3 C charge repel towards the left. When two charges will repel by equal force, +q charge will not feel any force.

So,

$$k \frac{(+5)q}{x^2} = k \frac{(+3)q}{(1-x)^2}$$

$$5(1-x)^2 = 3x^2$$

$$2x^2 - 10x + 5 = 0$$

$$x = \frac{10 \pm \sqrt{100 - 40}}{4}$$

$$x = 4.435 \text{ or } 0.565$$

As the value of x will be between 0 and 1, so the value of x must be 0.565. (Can you try what it would be if the value of x was 4.435?)

Question: There is a proton in the center of a hydrogen atom and an electron outside it. The charges of the proton and electron are $+1.6 \times 10^{-19} \text{ C}$ and $-1.6 \times 10^{-19} \text{ C}$ respectively. If the distance of the orbit of the electron from the nucleus is $0.5 \times 10^{-8} \text{ m}$, how much attraction is found between them?

Answer:

$$F = k \frac{q_1 q_2}{r^2}$$

Here,

$$q_1 = +1.6 \times 10^{-19} \text{ C}$$

$$q_2 = -1.6 \times 10^{-19} \text{ C}$$

$$k = 9 \times 10^9 \text{ Nm}^2/\text{C}^2$$

$$r = 0.5 \times 10^{-8} \text{ m}$$

therefore,
$$F = \frac{9 \times 10^9 \times 1.6 \times 10^{-19} \times (-1.6 \times 10^{-19})}{(0.5 \times 10^{-8})^2} \text{ N} = -9.22 \times 10^{-12} \text{ N}$$

Question: How much charge should be stored in the earth and the moon so that the gravitational force becomes zero and the moon goes out of its orbit?

Answer: The gravitational force acting between the earth and the moon:

$$F_G = G \frac{mM}{r^2}$$

Here,

$$G = 6.67 \times 10^{-11} \text{ Nkg}^{-2}\text{m}^2$$

$$m = 7.35 \times 10^{22} \text{ kg}$$

$$M = 5.97 \times 10^{24} \text{ kg}$$

$$r = 3.84 \times 10^5 \text{ km}$$

So,
$$F_G = \frac{6.67 \times 10^{-11} \times 7.35 \times 10^{22} \times 5.97 \times 10^{24}}{(3.84 \times 10^5)^2} \text{ N} = 1.98 \times 10^{26} \text{ N}$$

If an equal amount of charge is kept in the earth and moon, the repulsive force:

$$F_E = \frac{9 \times 10^9 \times q^2}{(3.84 \times 10^5)^2} \text{ NC}^{-2}$$

Two forces must be equal for reducing gravity by Coulomb force.

That is

$$F_G = F_E$$

$$1.98 \times 10^{26} \text{ N} = \frac{9 \times 10^9 \times q^2}{(3.84 \times 10^5)^2} \text{ NC}^{-2}$$

$$q^2 = 3.24 \times 10^{27} \text{ C}^2$$

$$q = 5.69 \times 10^{13} \text{ C}$$

Therefore, the number of electrons,

$$n = \frac{q}{e} = \frac{5.69 \times 10^{13} \text{ C}}{1.6 \times 10^{-19} \text{ C}} = 3.56 \times 10^{32}$$

The mass of an electron is $9.11 \times 10^{-31} \text{ kg}$, so the mass of all electrons:

$$(3.56 \times 10^{32}) \times (9.11 \times 10^{-31}) \text{ kg} = 324 \text{ kg}$$

So, if we can keep 324 kg electrons both in earth surface and in moon, the moon would come out of its orbit. (The mass of a moderate cow!)

10.5 Electric Field

The force between two charges can be determined by using Coulomb's formula. You may remember, for gravitational force, we have determined gravitational acceleration without beginning from gravitational force separately. Multiplying that acceleration with mass, we determine force.

In case of electric force, we can do that, we can define a new quantity called electric field. Multiplying charge q with this, we will get the force F acting on it. Therefore, any charge q creates an electric field around it. That electric field E is:

$$E = k \frac{q}{r^2}$$

If any charge q is brought in this electric field, then it will feel F force on it and the magnitude of F will be,

$$F = Eq$$

As force F is a vector and charge q is a scalar, so, E itself is a vector and its unit is N/C . You will see, this topic is easier to explain with the help of electric fields. Electric field cannot be seen, but to make it easy to understand, sometimes one type of completely imaginary lines are drawn, called the electric lines of force (first introduced by Michael Faraday). Our known world is three dimensional, so the lines of force will spread in all directions. To show you, these are drawn in a plane (Fig 10.11).

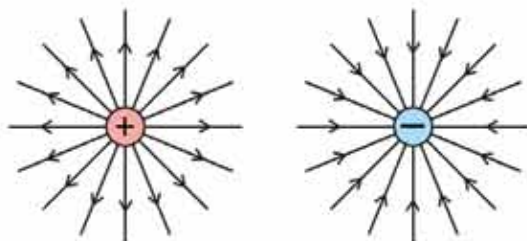

Figure 10.11: Lines of force diverges from positive charge and converges into negative charge

There are some rules of drawing lines of forces:

- In case of positive charge the lines of forces emerges from positive charges, and in case of negative charge converges into negative charges . In a specific point, the direction of lines of force is the direction of the electric field.
- The more the amount of charge, the more the number of lines of forces.
- The nearer the lines of force, the more the magnitude of the electric field.
- The lines of force of one charge never intercept the lines of force of another charge.

In Figure 10.12 (a), the lines of force of two opposite charges are shown. You can see, the lines of force of one charge ended up in another charge. Where the magnitude of the electric field is higher, the number of lines of force is higher. Also, when the figure is seen, it gives a feeling that the two charges are attracting one another. In Figure 10.12 (b), both the charges are positive and from the figure it can be seen that, the two charges are repelling one another. Not only that, in the middle portion of two charges the electric field due to one charge is neutralized by the electric field of the other. As a result the number of lines of force is less, and there is a point in the middle where the magnitude of

the electric field is zero. If both the charges were negative, then the direction of lines of force, would change only, besides this everything would be as before.

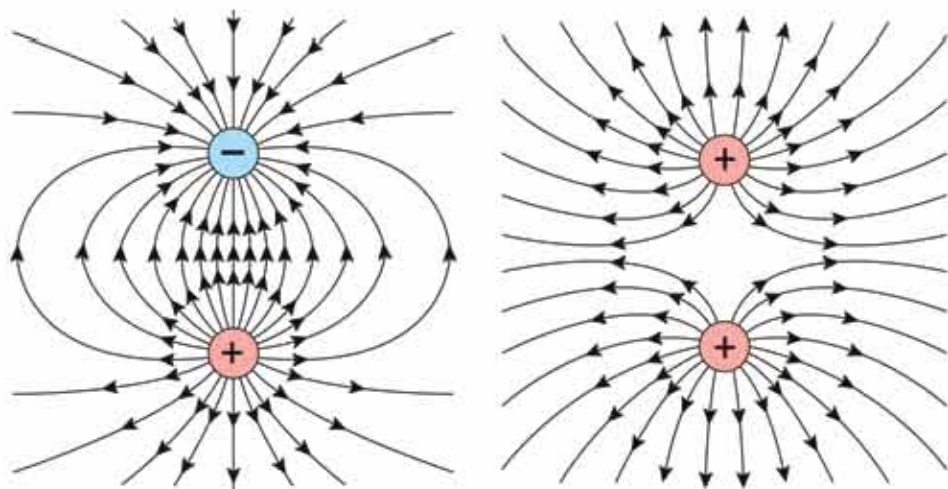

Figure 10.12: Lines of force of (a) opposite charge and (b) same charge



Example

Question: What is the magnitude of the electric field at a distance of 10 m for 5 C charge?

Answer: We know,

$$E = k \frac{q}{r^2}$$

Here,

$$q = 5 \text{ C}$$

$$q_2 = -1.6 \times 10^{-19} \text{ C}$$

$$r = 10 \text{ m}$$

$$k = 9 \times 10^9 \text{ Nm}^2/\text{C}^2$$

So,

$$E = \frac{9 \times 10^9 \times 5}{10^2} \text{ N/C} = 4.5 \times 10^8 \text{ N/C}$$

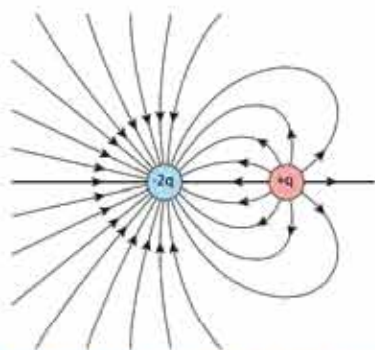

Figure 10.13: Lines of force for +q and -2q charge.

Question: A charge of 3 C is experiencing a force of 10 N. What is the electric field?

Answer: We know $F=qE$

So,

$$E = \frac{F}{q}$$

Here,

$$F = 10 \text{ N}$$

$$q = 3 \text{ C}$$

Therefore,

$$E = \frac{F}{q} = \frac{10 \text{ N}}{3 \text{ C}} = 3.33 \text{ N/C}$$

Question: If there are two charges q and $-2q$ close to each other, what will be their lines of force?

Answer: This is shown in Figure 10.13.

10.6 Electric Potential

You must have remembered that if there is water in two containers and a pipe is used to connect them, then water will go from the container with higher water level to the container with lower water level. From which container the water will go does not depend on the amount of water, but on the height of the water level. Similarly, we have also seen that if two materials of different temperature are in contact with each other then from which material the heat flows and to which direction as it goes does not depend on the amount of heat, it depends on the temperature. Heat will flow from the material with higher temperature to the material with lower temperature. Heat can even flow from a material with high temperature and less heat to a material with more heat.

When we discussed static electricity we said several times that if we

accumulate charge in a material and if it touches another material then charge will flow into the second material. Is there anything as charge and level of charge like amount of water and height of water level or amount of heat and temperature? What will decide from which material the charge will go to the other material? There is actually something like that and it is known as potential. If two materials have different amount of charges inside and if contact is made between them, then charges will flow to the material with the lower potential from the one with the higher potential.

If r is the radius of a metallic sphere and if it is given charge Q then its potential will be V

$$V = \frac{Q}{C}$$

Here C is the capacitance of the sphere. The value of C for a metallic sphere is

$$C = \frac{r}{k}$$

Where, $k = 9 \times 10^9 \text{ Nm}^2/\text{C}^2$

So, if there are two metallic spheres of radius R_1 and R_2 and both are given the same amount of charge Q , the sphere having the lower radius will have the higher potential. If the two spheres are connected using a wire, then charge will flow from the smaller sphere to the bigger sphere until the potential of the two spheres become the same (Figure 10.14).

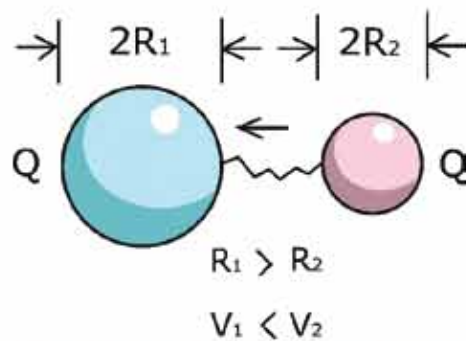

Figure 10.14: Charge flows from the higher potential to the lower potential.

We all are familiar with the unit of potential which is a volt. Now we will try to know what we really mean by potential.

We have compared potential with height of water surface or temperature, this comparison is right when we are concerned about the direction of charge flow but if we believe it literally then this is not correct, because potential is a more important quantity.

For example, let's assume positive Q charge is given to a metallic sphere of radius r , and then the potential of its surface is

$$V = k \frac{Q}{r}$$

What is its potential outside the surface? It is not zero at all. It is possible to determine potential around the sphere.

You know due to the presence of charge in a sphere, electric field E is created around it. So if a charge q is brought to it, the charge will experience a force F where,

$$F = Eq$$

As the charge Q on the sphere is positive and the charge outside the sphere q is also positive, so it will experience repulsion and if we release the charge q then it will have acceleration due to this force, velocity will increase etc. Again if we try to move the charge q closer to the sphere (Imagine the metallic sphere is fixed strongly and q charge is not able to move it) then work has to be done against the force, so the closer we take the charge towards the sphere the more potential energy it will have.

Potential is the amount of work done to move one unit charge (that is the value of q is 1) somewhere. (Assume it starts from far away, where electric field is not so prominent, so almost there is no force) If there is no charge around, then there is no electric field also, the charge will not experience any force, that means no work will have to be done to bring the unit charge, so we will say, there is no potential.

But if there is charge around, some work has to be done to bring the unit charge and the amount of work done is the potential. If W is the amount of work done to bring the charge q then potential V is,

$$V = \frac{W}{q}$$

If the charge of the sphere is negative, opposite things will happen, if the charge is released, then the charge will rush towards the sphere due to its attraction. So if we want to move the charge slowly from far away without creating any acceleration and giving no extra kinetic energy then we have to always pull the charge with a force which can balance the attractive force, that is, the charge is moving in a direction opposite to the direction in which we are

applying the force. So, the force we apply is doing negative work and we are withdrawing a part of the energy of this charge.

But in this case also, the potential is

$$V = \frac{W}{q}$$

We only have to keep in mind that as W is negative, so the value of V is negative.

Let's recap what we have learnt so far:

As there is an electric field where there is a charge, potential exists where there is charge. To speak the truth if we know why the potential exists, we will be able to find the electric field. How to find the potential, and then determine the electric field will be explained in the higher classes. In general, you may know one thing, the higher the change of potential, the higher will be the electric field.



Example

Question: What will be the state of the potential around a positive and a negative charge?

Answer: For the equal and opposite charges equipotential lines are shown in figure 10.15. On the left side the potential is positive and it turns negative on the right side by decreasing equally. Just at the center, the potential is zero.

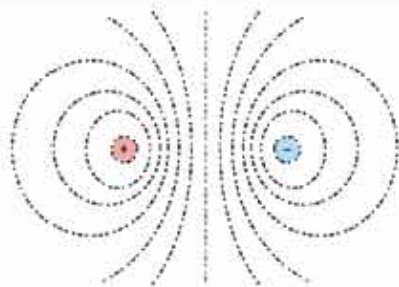

Figure 10.15: Equipotential lines for opposite charges.

10.6.1 Potential Difference

You must have seen different warning signs on electric lines, like, "DANGER 10,000 VOLT." You all know that there is a thing known as electric shock, it is very dangerous. There are also examples of careless people dying from being electrocuted. If you have understood potential then you can guess what actually happens.

If somewhere potential is high and if you touch it, since your body's potential is low so charge will flow into your body from the high potential region. Your body will have different consequences depending on the amount of charge passing through your body.

The potential of the object that you touch might be positive or negative. In one instance charge will leave your body and in the other charge will enter your body, both are electric currents- just with different directions.

You surely understand that charges flow due to a potential difference, not due to the value of the potential. That's why when a crow sits on a high voltage electric cable it doesn't get electrocuted, because the potential of the cable and the crow are equal. There is no difference. Not only this, but also workers work on high voltage cable of ten thousand or twenty thousand volts from a helicopter, use only bare hands. They don't get any electric shock. Because when they touch the high voltage cable, the potential of their body becomes equal to the potential of the cable as they are in air. There is no difference in potential, so no charge flows. They don't get an electric shock. This means the voltage difference is important, not the value of voltage- everyone should know this.

After all, when we need to measure voltage, it is good to have a fixed definite voltage for this. In the case of temperature there was an absolute zero temperature, here too there is something similar. We assume the earth to have zero potential. The earth is so large that if it is given some charge, earth can take it and the potential will not increase, again if some charges are taken the potential would not decrease. So everything is measured with respect to the earth, considering it as zero potential. You must have noticed that heavy electric equipments are always attached to the ground very well (Earthing). This means if a lot of charges start flowing after an accident then the charges can immediately and safely pass to the ground, without harming those who are around.

10.7 Capacitor

When heat is applied to a body, the amount by which its temperature rises depends on the heat capacity of that body. When the value of heat capacity is large enough, temperature rise will be small even if huge amount of heat is given to that body. On the other hand, if heat capacity is less, application of a small amount of heat will give a huge rise in temperature. Similarly, the increase in the potential of a body when charge is given to it depends on the capacitance of that body. When the capacitance of a body is large, and if a huge amount of charge is given to it, then a small amount of potential rise will take place, again when the

capacitance is small, and if a small amount of charge is given to it, the increase in potential will be high. We have discussed earlier that, when the capacitance of a body is C and if Q amount of charge is given to the body, then the potential V will be

$$V = \frac{Q}{C}$$

We have seen already that for a metallic sphere of radius r , the capacitance C is:

$$C = \frac{r}{k}$$

But the most simple and effective capacitor is made by keeping two metal plates side by side (Figure 10.16). If one plate is charged positively and the other is charged negatively, then an electric field is developed between the plates and energy is stored in that electric field. For a

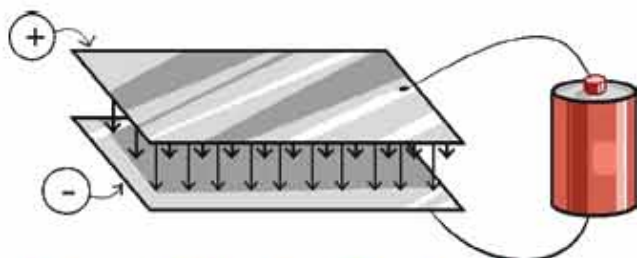

Figure 10.16: Capacitor formed by parallel metal plate .

capacitor, if capacitance is C and voltage is V , then the energy stored in it is:

$$\text{Energy} = \frac{1}{2} CV^2$$



Example

Question: What is the amount of stored energy if 10 V electric potential is applied to a $20\mu\text{F}$ capacitor?

Answer:

$$\text{Energy} = \frac{1}{2} CV^2 = \frac{1}{2} \times 20 \times 10^{-6} \times 10^2 \text{ J} = 10^{-3} \text{ J} = 1 \text{ mJ}$$

10.8 Uses of Static Electricity

We use electricity in our daily life, in industries, laboratories, educational institutions and hospitals etc. But we use current electricity (we will discuss it in the next chapter) in almost all of these cases. But static electricity is also used in some special cases:

10.8.1 Photocopy

All of us have used a photocopy machine now and then to copy some writing. In this machine, light is projected on the paper which creates an image of the writings on a special kind of roller. Static charges are created on the roller similar to the writings on the paper. After that, the roller is brought in contact with very fine powder like ink, and black ink is absorbed at the parts of the roller where charges are formed. Then this ink is imprinted on a new white page. The ink is attached very well to the paper by heating so that the ink doesn't scatter, and the process work in this way.

10.8.2 Van de Graaff Machine

Different types of work are done with high voltage. This can be done with a Van de Graaff machine using static electricity. Static charges are sprayed on a

rotating insulating belt, by rotating the belt it is taken inside a metallic sphere (Figure 10.17). A tangent (comb of sharp needle) receives the charge from above the belt and sends it to the metallic sphere. We know, charge always flows from higher potential to lower potential. It always happens in the Van de Graaff generator, because inside the metallic sphere the potential is equal to the potential of the surface. The excess voltage that is created on the belt due to the excess charge on the belt, is always higher than the voltage of the sphere. Due to this reason, any charge inside the sphere goes to the surface of the sphere. In this process,

by accumulating huge amount of charge on the sphere it is possible to develop high potential.

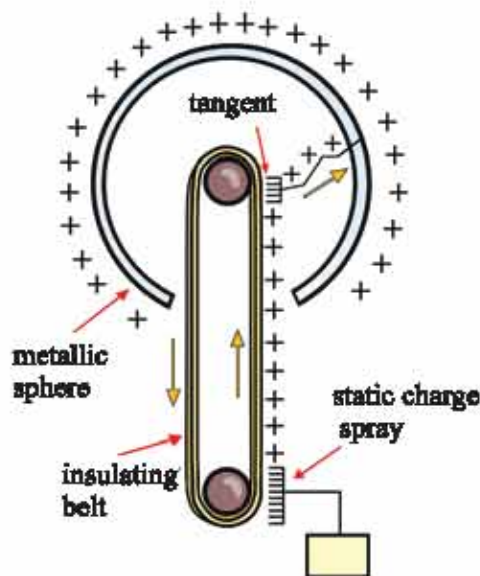

Figure 10.17: Van de Graaff Machine

10.8.3 Fuel Truck

When petrol or other fuel trucks supply fuel, then they have to be very careful so that no electrical sparks are created suddenly which may produce a big explosion. This may happen if static electricity is generated due to friction between truck wheels and the road. So behind the truck, a metal chain hangs from the tank and stays in contact with the ground. In this way, any static electricity produced is directly transferred to the earth through the chain.

10.8.4 Electronics

In cold countries, the amount of water vapor in air is very low and the effects of static electricity are very high. Many types of IC (Integrated Circuit) are used while working with electronics. Some IC's can be damaged by even a slightest change of voltage to their pins. That is why a touch of the hand while working with electronics can damage a valuable IC or the circuit board. For doing work under these circumstances, the upper part of a table is connected to the ground with a conducting wire. Simultaneously, the hands of the person working are connected to the ground using an electrical conducting strap.

10.8.5 Lightning and Lightning Arrestor

When water vapor rises to form clouds, the negative charges (electrons) created due to friction between water vapor are stored in the lower altitude clouds. So naturally a shortage of electrons is developed in the higher clouds making them positively charged. When a large amount of charge is accumulated in the clouds, a huge spark is formed inside the clouds to return to neutral state (which we know as lightning). Sometimes so much charge is accumulated in the clouds that they ionize the air and literally travels to the ground. We call that a thunderbolt. A huge amount of charge is brought to the earth during a thunderbolt. It ionizes the air while travelling through it, so a huge amount of heat, light and sound is produced, and such amounts of charge can cause serious harm to the places nearby.

Millions of amperes of electric current can flow during a thunderbolt and for this flow of current, the temperature of the air can rise up to 20-30 thousand degree Celsius which is even more than the temperature of the sun!

For this temperature we see a bluish white sparkling in the sky. Another thing occurs due to this temperature; the air expands to a great extent and moves outside, and in the very next moment air from the outside fills in that blank space created. This whole thing occurs faster than the speed of sound and an incredibly loud noise is created. When the speed of air exceeds that of sound, it is called a

shockwave. The sound of a thunderbolt is a kind of shockwave. Although the flashing of light and sound are created at the same time, we see the light first, since the speed of light is so much that it reaches us within the next moment. The speed of sound is 330 m/s which means it takes 3 s for it to travel one kilometer. That is why; we can guess the distance at which the lightning is created by calculating how many seconds later we hear the sound of thunder. Roughly 3 seconds for a kilometer.

Since electric current flows down from the clouds during a lightning, it usually strikes tall structures. So to protect tall buildings from thunderbolts, more than one pointy metal needle is set up on the roof. This current is then transferred to the ground by some heavy conducting wires. The science behind this is very simple. We have seen earlier that when a charged object is brought near an uncharged body, the uncharged body becomes induced by opposite charge. So while the possibility of a thunderbolt occurs, the pointy needles become positively charged and an intense electric field is created due to pointy needles. The surrounding air and water vapors become ionized due to this electric field and these rises above and neutralizes the negative charges of clouds and reduces the possibility of being a thunderbolt. When thunder needles are kept on the roof of a tall building they often absorb the thunderbolt and the bar carries the huge amount of charges directly to the ground. So the current coming down from the sky doesn't go to the ground uncontrolled; rather it goes to the deep ground through the heavy wire.

Not only thunderbolt occurs in the pointy needles, but also the needles can pass opposite charges to neutralize the charges stored in the clouds. That is why, when lightning arresters are installed in tall buildings, the risk of that building being thunderstruck is reduced greatly.

10.8.6 Static Electric Color Spray

Static electric color sprays are used now-a-days to paint cars, bicycles, steel cupboards and other metallic things. In these sprays very small particles of colors are created and since they are charged, while getting out one particle repels another particle and spreads out. So a large space can be smoothly painted using spray.

To charge the color particles, the pointy head of the spray is connected with a high potential source. The thing to be charged is connected with the opposite potential or the earth. As the color particles are charged, they are attracted towards the body and firmly attached with the body. Not only that, the color

particles can travel along electric lines of force and can reach the hidden corners and create a layer of paint in there.



Investigation 10.01

Friction and induction

Objective: To create charges from friction and induction

Apparatus: Comb, aluminium foil.

Theory: While combing hair in winter, negative charges get stored in the comb.

Working Procedure:

- 1) Take a very small piece of aluminium foil and roll it into a ball.
- 2) After combing the hair, bring the comb close to the aluminium foil ball. If enough negative charges are accumulated on the comb, it will induce a positive charge at the front side of the ball. (Since aluminium foil is a conductor, the electrons in front will easily move back.) The front side will be attracted by the comb and the ball will jump and stick to the comb.
- 3) Again since the aluminium foil is a conductor, negative charges will get absorbed immediately and will fall down being repelled by the comb.



Exercise



General questions

1. There is a minimum value of charge; this is $1.6 \times 10^{-19} \text{C}$, is there a similar minimum value of mass?
2. Why is it that static electricity experiments don't work properly during rainy season?
3. Can you give equal and opposite charges to two similar metallic spheres without touching them?
4. If capacitance is compared to a container, then what should potential be compared to?
5. Is it possible for a point to have zero potential but non-zero electric field?
6. Explain the phenomenon of charging a body based on the basis of structure of atom.
7. Describe how a body can be charged by the process of friction.
8. What is electrostatic induction?
9. What is inducing charge and induced charge?
10. Describe how a body can be charged by the process of electrostatic induction?
11. Describe the construction of a gold leaf electroscope.
12. Describe how a gold leaf electroscope can be charged positively.
13. How can the nature of charge of a charged body be determined by a gold leaf electroscope?
14. What are the factors on which the electrostatic force between two charges depends?



Mathematical questions

1. 4C and -1C charges are kept 1 m apart. At which point of the line joining them, is the magnitude of the electric field zero?
2. An electron in a hydrogen atom revolves around the nucleus due to Coulomb's force. The mass of electron is $9.11 \times 10^{-31}\text{ kg}$ and proton is $1.67 \times 10^{-27}\text{ kg}$ and for this there is also a gravitational force between them. Which of these two forces is greater and by how much?

- Draw the electric lines of force for the two charges mentioned in question number 1.
- Equipotential lines for opposite charges are shown in Figure 10.15, show electric field from there.
- Electric field for two charges is shown in Figure 10.13, draw the potential.



Multiple choice questions

Choose the correct answer

1. The name of the apparatus used to determine the presence of charge is –

- a) Ammeter b) Voltmeter
c) Microscope d) Electroscope

2. On which factor does the electrostatic force between two charges not depend?

- i) the distance between the charges
ii) the nature of the medium in which the charges are placed
iii) the masses of the charges

Which one of the following is correct?

- a) i and ii b) iii
c) ii and iii d) i, ii, and iii

3. The unit of electric field intensity is-

- a) N b) N m
c) $N\ m^{-1}$ d) $N\ C^{-1}$

4. Volt is the unit of what?

- a) electric field b) electric potential
c) electric charge d) electric current

5. In Figure 10.18

- i) some charges will flow from sphere A to sphere B
ii) some charges will flow from sphere B to sphere A
iii) the charge difference remains same

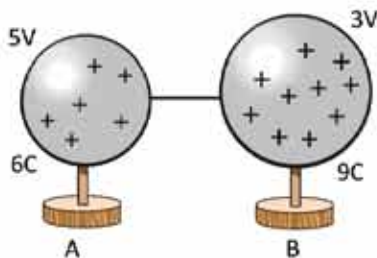

Figure 10.18

Which one of the following is correct?

- a) i b) ii
c) iii d) i, ii, and iii



Creative questions

1. Rima, after combing her hair, observes that her comb attracts small pieces of paper. Shima says that it happens because the comb is positively charged. Rima says that the comb is charged negatively. To solve the problem, Rima and Shima look for their physics teacher and find him in the physics laboratory. Hearing everything he asks them to find the nature of the charge with the help of an electroscope.

- (a) What do you mean by charge?
(b) Explain why an object is charged by friction?
(c) Describe why the comb is charged?
(d) Explain how the nature of charge of the comb can be determined by the electroscope.

2. Figure 10.19

- (a) What is an electric field?
(b) If the position of the object at P is changed, what kind of change of force it takes?
(c) Find the electric field intensity at point P of Figure (a).
(d) Explain the change of force of Figure (a) than in Figure (b).

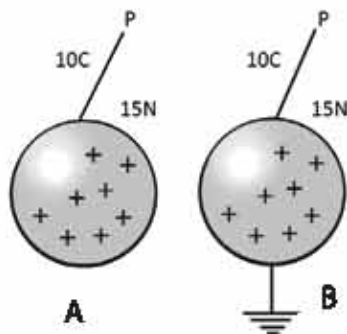

Figure 10.19

3. $q_1(2C)$, $q_2(-1C)$ and $q_3(1C)$ are three charges placed on a straight line sequentially and equidistant from each other.

- (a) What is electric force?
(b) Why are electric field and electric field intensity not the same?
(c) Draw the lines of force produced by three charges.
(d) What should be the magnitude of charge q_1 be, so that charge q_3 will not feel any force on it? Explain.

Chapter Eleven

Current Electricity



Now-a-days, we cannot spend a single moment properly without electricity. To operate machines and other instruments around us, we need electricity. In the previous chapter we discussed static electricity. When charge flows through a conductor, we call it current electricity or, in brief, electricity. We will describe the terms required to explain current electricity and learn the rules of flow of electricity. In this chapter we will also discuss how we can measure electricity in a circuit and potential difference.

**By the end of this chapter we will be able to-**

- demonstrate the production of current electricity from static electricity.
- explain the direction of electric current and flow of electrons.
- draw a circuit by using the symbols of electric devices and appliances.
- explain conductors, insulators and semiconductors.
- establish a relationship between electric current and potential difference by using a graph.
- explain fixed resistance and variable resistance.
- explain electromotive force and potential difference.
- explain dependence of resistance.
- explain resistivity and conductivity.
- use series and parallel resistance.
- use an equivalent resistance in a circuit.
- calculate electric power in a circuit.
- explain system loss and load shedding in a circuit.
- describe the safe and effective use of electricity.
- draw a typical house circuit and demonstrate the use of AC sources in its different parts.
- draw a poster to build consciousness about dissipation and conservation of electricity.

11.1 Electric current

We have discussed in the previous chapter that if two bodies have a potential difference, then charge flows from the body of higher potential to the body of lower potential. The flow of charges continues until the potential becomes equal. This flow of charge is the flow of current or electricity, which we generally call “electricity”. Using this electricity, lights turn on, the fan rotates, and the phone charges!

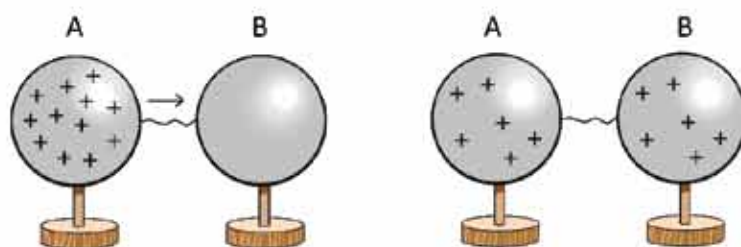

Figure 11.01: Electricity flows from a charged sphere to an uncharged sphere.

11.1.1 Electromotive Force and Potential Difference

You can understand that electricity flows only if there is a potential difference. If we want to get a continuous flow of electricity, we have to always maintain a potential difference and cannot let it be equal. If potential is created using a positive charge in a sphere and then connecting it with another uncharged sphere (Figure 11.01) by a metal wire, as the electricity starts flowing, the potential difference will start decreasing and the potentials will become equal! It is possible to develop a potential difference between the two plates of a capacitor by accumulating charges there. But if the plates of the capacitor are connected with a wire, the potentials will become equal due to flow of charge.

So you can understand that if we want a continuous flow of electricity, we need some other process which will maintain a potential difference that will not decrease with the flow of charges. All of you have seen such technique; these are battery cells or generators. Potential difference is

produced by a chemical reaction inside the battery cell, if the flow of charge starts, chemical substances start decreasing. When chemical substances are finished, battery cells cannot create a flow of electricity. The ordinary battery cells that we see regularly have a potential difference of 1.5 volt.

For the supply of electricity that you have in your school or residence, there are two points for using it, one of them is at higher potential and the other one is at lower potential. This difference in potential is maintained by a generator, which develops this continuously. A battery cell or a generator has to send charges continuously from low potential to high potential for continuous flow of electricity, and for that it needs energy. If W amount of work is done to bring Q amount of charge from low potential to high potential in a battery, then the electromotive force or e.m.f of the battery is:

$$EMF = \frac{W}{Q}$$

A battery cell or a generator which supplies electric energy has an electromotive force or emf. When a battery cell or a generator is connected to a circuit, this electromotive force brings the charge through the whole circuit.

The amount of potential a battery produces is its electromotive force or emf. In English it is called “force” but in Bengali it is “energy”. Actually, this emf or electromotive force is not force or energy at all. We said earlier that in physics terms like “force” and “energy” are very specific. We cannot use one word instead of the other. Unfortunately this has been done here. But don’t be

confused, because the potential that a battery or generator creates is its EMF, so we will start from there. We will use the word potential everywhere and will not face any problem.

We said earlier that the magnitude of the potential is not important, the

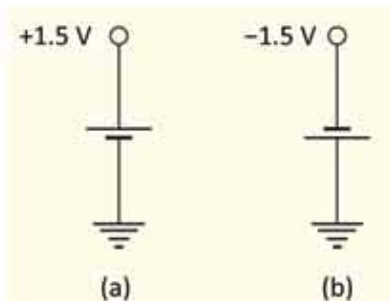

Figure 11.02: It is possible to make positive and negative voltage by a battery cell

difference of it is important. So you will see that the value of potential of one terminal of a battery cell can be made different, but the difference will remain the same.



Example

Question: The potential difference of a battery cell is 1.5V. What is the actual potential of both terminals? Negative is zero and positive is 1.5V? or negative one is -1.5 V and positive one is zero?

Answer: Both of them can be true. If it is like Figure 11.02 (a) then the negative is zero and the positive is 1.5 V. But if it is like 11.02 (b) then the positive is zero and the negative is -1.5 V.

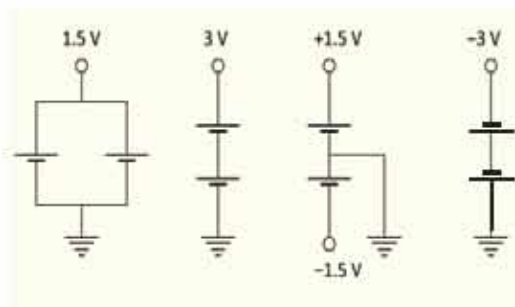

Figure 11.03: Different positive and negative voltages are made using two battery cells.

Example: Make voltage 1.5 V, 3.0 V, -1.5 V, -3.0 V using two 1.5 V battery.

Answer: This is shown in Figure 11.03.

11.1.2 Conductor, Insulator and Semiconductor

Conductor: If we have understood the structure of matter properly, then we have understood one thing clearly. In solids the atoms and molecules strongly hold their own positions. If temperature is increased the atoms or molecules start vibrating, staying at their own position, and don't move away from their positions. When you learnt metallic bonds in your chemistry book, you have seen, some electrons of metal atoms are in a free state which can move from one place to another. For this reason, those are called conductors. Gold, silver, copper, aluminum etc. are good conductors. Charge can be transferred through conductors, but we have to remember that this transfer of charge is done by

electrons; flow of electricity is done by electron, negatively charged electrons!

Insulator: The substance which has no free electron for conducting electricity is called an insulator. Plastic, rubber, wood, glass are examples of insulators. Mainly, non-metals are insulators.

Semiconductor: There are some substances whose conductivity lies between insulators and conductors at normal temperature, but their conductivity increases with the rise of temperature. These types of substances are called semiconductors. Silicon or germanium examples of semiconductors. Semiconductor are elaborately discussed in the last chapter of this book.

11.1.3 Direction of electric flow

We have seen that if two bodies of different potentials are connected by a conductor, charge starts flowing and it continues until the potentials become equal and we say electric current is flowing. Many of you may have started thinking because when we talked about equalizing two different potentials by flow of charge, we said that it is true for negative charges, as only negatively charged electrons can go from one place to another. Then what happens in case of positive charge? As the positive ions are strongly bounded in their own positions, how does positive charge move from one place to another?

You may have already realized what happens in that case. The deficiency of electron is positive charge. So increasing the deficiency by moving electrons means a supply of positive charge! So, if it is said that in Figure 11.01 positive charge moves from A to B by flow of electricity, actually it means that electrons move from B to A.

The flow of charge is electric current. So far, we have tried to understand it normally. Let us specify it a little bit now. Electric current means the rate of change of flow of charge with respect to time i.e. if Q charge flows in time t , the electric current is:

$$I = \frac{Q}{t}$$

If the unit of charge is the Coulomb (C) and of time is second (t), then the unit of electric current is ampere A. Interesting thing is, to find the unit of charge we said, if one ampere electric current flows for one second then the amount of charge that flows is called 1 Coulomb. Electric current is the rate of flow of charge; if 1 ampere current flows from A to B, it means 1 coulomb positive charge has been moved from A to B. Which actually means that the amount of electrons equivalent to 1 Coulomb charge has been moved from B to A. Therefore, you see that the direction of electric current is opposite to the direction of flow of electrons. (All problems could have been solved if we assume the charge of electron is positive, but it has been too late!)

11.2 Relationship between Potential Difference and Electricity

Now we will discuss actual flow of current in a real circuit. We have said before that if there is a potential difference between two points and if we connect these two points with a conducting wire, electric current will start flowing between the points, though we haven't discussed the amount of electric current. Not only that, will the amount of current that flows if the connection is made by a gold wire be equal to the current that will flow through the connection made by an iron wire?

11.2.1 Ohm's Law

To see the relationship between potential difference and electric current we can do an experiment. The equipment used for measuring voltage is called a voltmeter, and the equipment used for measuring current is known as ammeter. (Actually the same equipment can be used sometimes as a voltmeter and sometimes as an ammeter by turning a switch.) Let us take a few battery cells. If the voltage for one battery cell is 1.5 V, for two cells it will be $2 \times 1.5 = 3$ V, for three cells it will be $3 \times 1.5 = 4.5$ V. We can apply different potential differences in

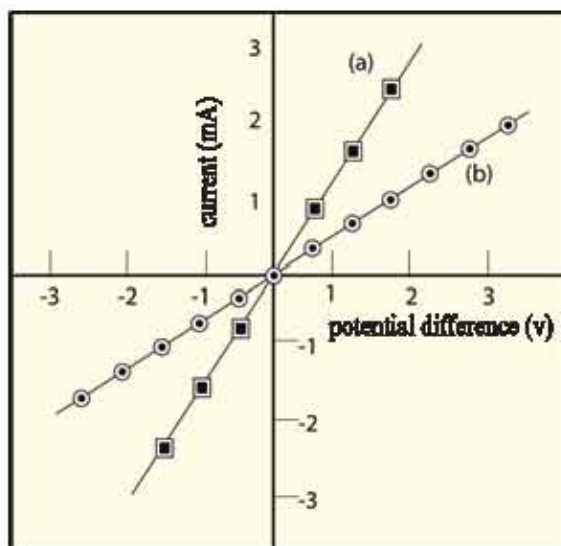

Figure 11.04: Current flow relative to potential differences due to resistance

this way. Not only this, we can also change the direction of the potential difference by reversing the cells. So if we apply different positive and negative potential differences between two sides of a wire or some other conductor and try to measure the current that flows, we will see that

- a) The higher the potential difference the higher the current flow.
- b) If potential difference is negative, the electric current also changes direction.

If we put the result of the experiment on a graph, it will be like figure 11.04 (a):

Therefore,

$$I \propto V$$

If we do the same experiment by using a wire of some other materials, we will get similar results. But the slope of the straight line may be different. (Figure 11.04(b)) Now if we analyze the results of these two experiments, we will understand that for a certain potential difference, the current that flows through the first conductor is more than the current that flows through the second conductor for the same potential difference. It is as if the flow of current is easier through the first conductor and a little difficult through the second one. To explain the matter, a quantity named 'resistance to current flow' or simply 'resistance' has been introduced. We can see that the relation between voltage and electric current can be expressed by a law which is known as Ohm's law.

$$I = \frac{V}{R}$$

So, the higher the resistance, the lower is the electric current. And the lower the resistance, the higher is the current.

The unit of resistance is Ohm and it is expressed by the Greek letter Ω . If 1 V potential difference is applied in an electric circuit and if it is seen that 1 A current flows as a result, it can be said that the resistance of the circuit is 1 Ω .



Example

Question: To make fun you can write Ohm's law differently:

$$\frac{V}{I \times R}$$

After writing in big font size, cover any of V , I or R with finger. The value of the covered one will be obtained from the uncovered ones.

Answer: It is shown in fig 11.05.

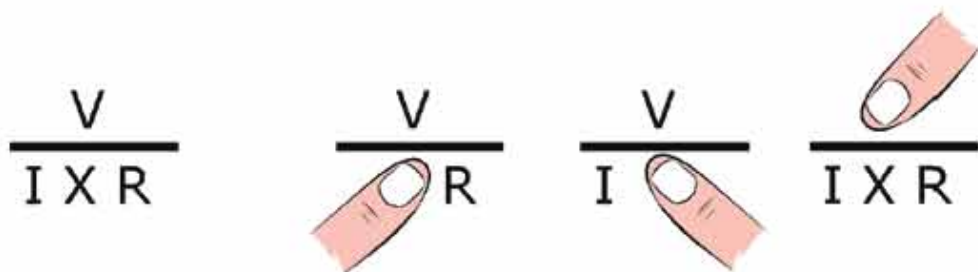

Figure 11.05: Ohm's law can be used by this figure. The value of the covered quantity by the finger can be expressed by the two other quantities.

11.2.2 Resistance

Resistance is the obstacle to the flow of current. So the more the length of a material L , the higher is the hindrance, and resistance.

$$R \propto L$$

Again current can flow more easily through a wide path than through a narrow path. So, the higher the cross sectional area A of a conductor, the lower is the resistance.

$$R \propto \frac{1}{A}$$

If we want to write these two things as an equation rather than in proportional form, a constant ρ has to be used. So, resistance R is,

$$R = \rho \frac{L}{A}$$

Where the constant ρ is,

$$\rho = R \frac{A}{L}$$

For a certain material, ρ is specific resistance and its unit is $\Omega \text{ m}$.

To measure how conducting a substance is, a term called conductivity σ has been introduced. The more a substance is electrically conducting, the more is the value of the electrical conductivity. It is reciprocal to the specific resistance ρ . (Table 11.01)

$$\sigma = \frac{1}{\rho}$$

The unit of conductivity σ is: $(\Omega \text{ m})^{-1}$

We have to remember one thing; the resistance of a substance is the hindrance to electron flow.

The more the atoms and molecules vibrate the more the barrier the electrons will face while going through them. In other words, the more the resistance. As the vibrations of the atoms and molecules increases with the increase in temperature, so the specific resistance of a conducting substance also increases with temperature. So the temperature has to be specifically mentioned while expressing resistance or specific resistance of a substance.

Fixed Resistance: Resistors with a definite value are used in different circuits. They can be of different shapes and of different types. The resistances that are used in laboratory uses, generally the value of the resistances are expressed by using bands of different colors on them. How much electric power they can tolerate is also specified along with the value of the resistance.



Figure 11.06: (a) Fixed and (b) variable resistors

Table 11.01 : Specific resistance of matter

Matter	Specific resistance ($\Omega \text{ m}$)
Silver	1.59×10^{-8}
Copper	1.68×10^{-8}
Gold	2.44×10^{-8}
Graphite	2.50×10^{-6}
Diamond	1.00×10^{12}
Air	1.30×10^{16}

Variable Resistance: Sometimes an electric circuit needs a resistance, the value of which can be changed as per need. The type of resistance, whose value can be changed within a certain limit, is called a variable resistance or a Rheostat. A fixed resistance has two ends, whereas a variable resistance has an additional terminal in the middle, where the changed value of the resistance is obtained. It is shown in Figure 11.06.



Example

Question: The specific resistances ρ of silver, copper, tungsten and nichrome wire are 1.6×10^{-8} , 1.7×10^{-8} , 5.5×10^{-8} , $100 \times 10^{-8} \Omega \text{ m}$ respectively. Using these make a 1Ω resistance.

Answer:

We know,

$$R = \frac{\rho L}{A}$$

where, L is the length and A is the cross-sectional area.

So, if we consider, $A = 1 \text{ m}^2$

$$L = \frac{RA}{\rho} = \frac{1 \times 1}{\rho} = \frac{1}{\rho}$$

For Silver,

$$L = \frac{1}{1.6 \times 10^{-8}} = 6.25 \times 10^7 \text{ m}$$

For Copper,

$$L = \frac{1}{1.7 \times 10^{-8}} = 5.9 \times 10^7 \text{ m}$$

For Tungsten,

$$L = \frac{1}{5.5 \times 10^{-8}} = 1.8 \times 10^7 \text{ m}$$

For, Nichrome

$$L = \frac{1}{100 \times 10^{-8}} = 10^6 \text{ m}$$

You can see, to create a 1Ω resistance, the length has to be very very long (almost 1 Lac kilometer). Practically, very thin wires are used, so $A = 1 \text{ m}^2$ is not usually feasible. If we fix the radius as 0.1 mm , then how long will a wire need to be to make a 1Ω resistance?

We know,

$$L = \frac{RA}{\rho}$$

$$A = \pi r^2 = \pi(10^{-4})^2 m^2 = 3.14 \times 10^{-8} m^2$$

For silver,
$$L = \frac{3.14 \times 10^{-8}}{1.6 \times 10^{-8}} = 1.96 \text{ m}$$

For copper,
$$L = \frac{3.14 \times 10^{-8}}{1.7 \times 10^{-8}} = 1.84 \text{ m}$$

For tungsten,
$$L = \frac{3.14 \times 10^{-8}}{5.5 \times 10^{-8}} = 0.57m = 57 \text{ cm}$$

For Nichrome,
$$L = \frac{3.14 \times 10^{-8}}{100 \times 10^{-8}} = 0.03m = 3 \text{ cm}$$

If the temperature of a conductor is raised, its resistance increases, but the case is the opposite for a semiconductor. The resistance decreases if the temperature goes up in a semiconductor. The reason is, there are free electrons in a conductor for the flow of current, but a semiconductor does not have free electrons. If the temperature is raised, some electrons are found for the flow of current, so a temperature rise causes the decrease of resistance of a semiconductor.

11.2.3 Circuit

If we have understood Ohm's law, we should be able to analyse circuits now. Before that, let us introduce some of the symbols that are used in circuits: (Figure 11.07)

Every substance has some resistance, but we do not consider the resistance of electrical wires while using them in circuits in our daily life. When a resistance is needed, we use different resistances prepared in special ways. Sometimes we use such resistances for some special purposes, where even their magnitudes can be changed, these are called variable resistance or rheostat.

To analyze a circuit, some simple points discussed below are to be remembered:

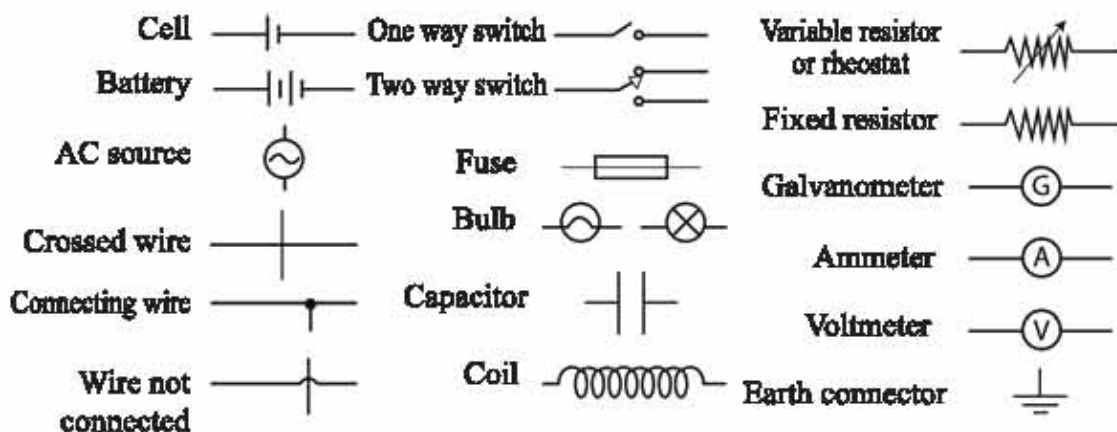

Figure 11.07: Some symbols that are used in a circuit.

(a) The amount of current that comes out from the higher potential of a source (battery cell, generator whatever may be) after flowing through the entire circuit, just the same amount of current comes back to the lower potential.

(b) The amount of current that enters at any point of a circuit, the same amount of current will come out from that point, that is, there is no creation or destruction of current in a circuit.

(c) In a circuit Ohm's law is true for two points in any part, that is, if the potential difference of those two points is divided by the resistance of that part, the current flowing through the circuit can be determined.

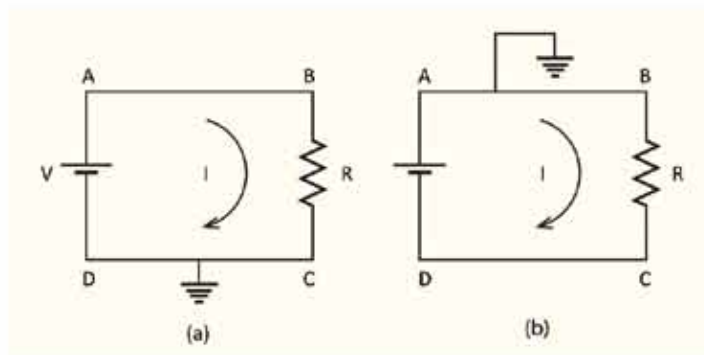

Figure 11.08: Two circuits with a battery cell and a resistor.

Now we are ready to analyse a circuit. We may think that we have understood the circuit completely if we can find out the potential difference in any part of the circuit and how much current is flowing through that part. There may be many components in a circuit like battery cell, resistance, capacitor, diode, transistor etc. But now we will analyze the circuit composed of only the battery cell and resistance. In a circuit, resistances are connected with copper wires, though we have seen that copper wire has a specific resistance. But in reality, the resistance of the connecting wires is very small with respect to the resistances we use in a circuit, so, we do not consider it at all. We will assume that the wire has no resistance and the potential is the same over the whole wire.

Now, let us analyse a circuit as shown in figure 11.08(a), here, a resistance is connected to the two terminals of a battery cell with two wires. Since the part CD is connected to the earth, so we can say that the potential of the lower terminal of the battery cell is zero. So, the upper terminal of the battery has a potential V and there is a resistance in part BC, potential difference between two ends of the resistance is,

$$V - 0 = V$$

If the resistance is R , the current I flowing through it will be,

$$I = \frac{V}{R}$$

So, current I comes out from point A of the battery and enters into point B. We have determined the voltage and current at every point of the circuit.

Let us assume in the same circuit, if we connect AB part with the earth rather than part DC (Figure 11.08(b)) what will happen then? As the voltage of the battery cell is V volt, so the potential difference between A and D must be V , as the voltage of A is zero, so the voltage of D must be $-V$. Therefore, the potential difference between B and C has to be,

$$0 - (-V) = V$$

Resistance is R , so electric current:

$$I = \frac{V}{R}$$

This is the same as the previous value, which is what it is supposed to be. See, the magnitude of the potential has changed but the difference is the same.



Example

Question: Determine the voltage at the points A, B, C and D of the circuit in figure 11.09 (a).

Solutions: Voltage at C and D is 0, voltage at A is 3V. To calculate the voltage at B, current I of the circuit has to be determined.

$$I = \frac{V}{R} = \frac{3}{1+2} \text{ A} = 1.0 \text{ A}$$

So, the reduction in voltage from A to B is,

$$V = RI = 1 \Omega \times 1 \text{ A} = 1 \text{ V}$$

So, voltage at point B, $3\text{V} - 1\text{V} = 2\text{V}$

As the voltage (potential) at all points has been found, verify whether Ohm's law works or not?

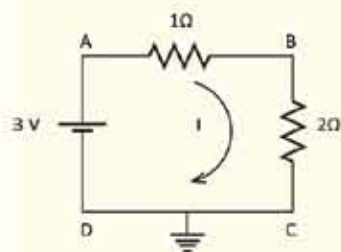

(a)

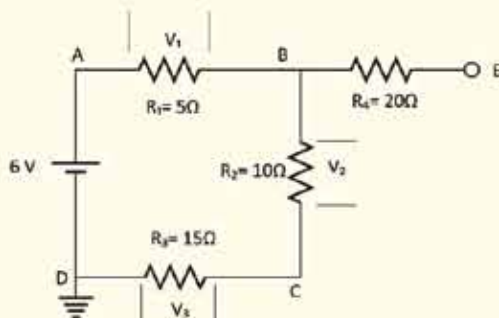

(b)

Figure 11.09: Two circuits composed of a battery and more than one resistor.

Question: Determine the voltages at the points A, B, C, D and E of the circuit in figure 11.9 (b).

Solution: Voltage at D is zero

Voltage at A is 6V

What may be the voltage at E, how can it be determined, many of us may be confused about this. Actually the case is very simple. When current flows through a resistance, the voltage changes. There is no chance of current flow in this part BE of the circuit. It can go nowhere after reaching E starting from B. So, the voltage at B and E (and any point between them) does not change, the voltage at B remains the same at E.

To determine the voltages of B and E, the current has to be determined. If current is I , then

$$I = \frac{V}{R} = \frac{6 \text{ V}}{5 \Omega + 10 \Omega + 15 \Omega} = \frac{1}{5} \text{ A}$$

So, voltage difference from A to B,

$$V_1 = R_1 I = 5 \Omega \times \frac{1}{5} \text{ A} = 1 \text{ V}$$

So, the voltage at A is 6V and 1V less at B so, the voltage at B is,

$$6 \text{ V} - V_1 = 6 \text{ V} - 1 \text{ V} = 5 \text{ V}$$

As the voltage of point B is 5 V, then the voltage of point E is also 5 V. Similarly,

$$V_2 = R_2 I = 10 \Omega \times \frac{1}{5} \text{ A} = 2 \text{ V}$$

The voltage at C is 2 V less than voltage of point B. So, voltage of point C is, $5\text{V}-2\text{V}=3\text{V}$

We have said earlier that the voltage of point D is zero. This can also be verified. The voltage of point D is less than point C by V_3 .

$$V_3 = R_3 I = 15 \Omega \times \frac{1}{5} \text{ A} = 3 \text{ V}$$

So, voltage of point

D = $3\text{V} - 3\text{V} = 0$, as mentioned earlier.

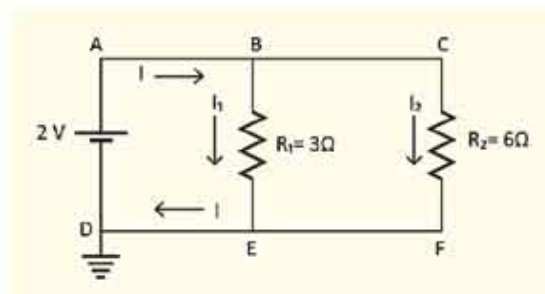

Figure 11.10: A circuit where two resistors are connected in parallel.

Question: Determine the value of I_1 and I_2 in the circuit shown in figure 11.10.

Solution: Voltage at points A, B and C is 2V.

Voltage at points D, E, F is 0 volt. So, the current through the resistor BE,

$$I_1 = \frac{V}{R_1} = \frac{2}{3} \text{ A}$$

The current through resistor CF,

$$I_2 = \frac{V}{R_2} = \frac{2}{6} \text{ A} = \frac{1}{3} \text{ A}$$

Total current,

$$I = I_1 + I_2 = \frac{2}{3} \text{ A} + \frac{1}{3} \text{ A} = 1 \text{ A}$$

11.2.4 Equivalent Resistance: Series Circuit

If there is more than one resistance in a circuit, we will see how these resistances can be considered as a single equivalent resistance. In figure 11.11 there are two resistances in the circuit, as C is connected to the ground so its potential is zero and the potential of A is V . We don't know the potential of B, but we know that the same amount of electric current I flows through R_1 and R_2 .

To keep it simple, we can say, the sum of two resistances is the total resistance R and the current will be $I = V/(R)$, but let us prove this rather than writing it.

Let us assume the potential at point B is V_B , then for the first resistance R_1 we can write:

$$I = \frac{V - V_B}{R_1}$$

Again we can write for the second resistance R_2 :

$$I = \frac{V_B - 0}{R_2} = \frac{V_B}{R_2}$$

Therefore,

$$I = \frac{V - V_B}{R_1} = \frac{V_B}{R_2}$$

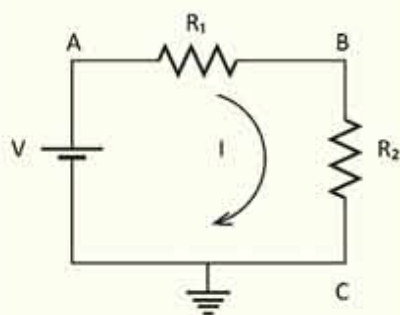

Figure 11.11: Two resistances connected one after another in a circuit.

$$(V - V_B)R_2 = V_B R_1$$

$$V_B(R_1 + R_2) = V R_2$$

Therefore,

$$V_B = \frac{R_2}{R_1 + R_2} V$$

$$I = \frac{V_B}{R_2} = \frac{V}{R_1 + R_2}$$

We can imagine resistances R_1 and R_2 as a single resistance R , where

$$I = \frac{V}{R}$$

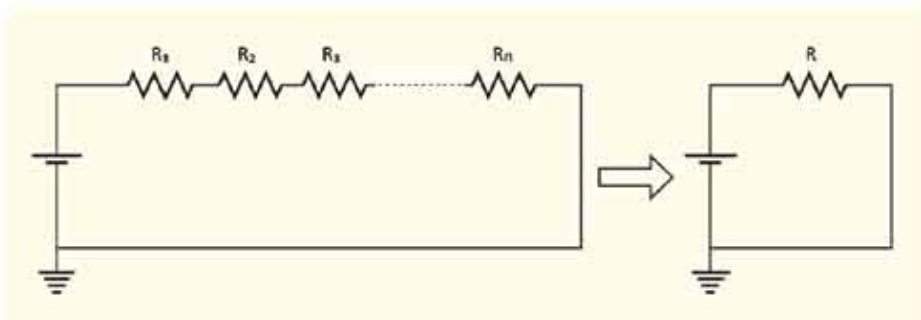

Figure 11.12: Many successive resistances or resistors connected in a circuit can be imagined as an equivalent resistance or resistor.

If there were more than two resistances (figure 11.12) then also we would be able to show that these resistances can be combined as a single resistance R which will be the sum of all those resistances. This is called the equivalent resistance. This means when a circuit will have $R_1, R_2, R_3 \dots$ resistances successively (series circuit) then the equivalent resistance will be:

$$R = R_1 + R_2 + R_3 \dots R_n$$

11.2.5 Equivalent resistance: Parallel circuit

Now we will place the resistances in parallel instead of one after another (Figure 11.13). In this circuit we have named different points as A, B, C, D, E and F. We can understand from the figure that points D, E and F are connected to the ground and so their potentials are zero. So the potential of points A, B, and C is V .

Current I flows from the battery cell. This current goes to point B and splits into two parts I_1 and I_2 and flows through the resistances R_1 and R_2 respectively, then at point E the currents converge into I and go back to the battery as I . We have already said that the current comes from the battery and flows through the circuit and then goes back to the battery. No electric current can be created or destroyed except this in a circuit. So

$$I = I_1 + I_2$$

Now we can find I_1 and I_2 :

$$I_1 = \frac{V_B - V_E}{R_1} = \frac{V - 0}{R_1} = \frac{V}{R_1}$$

$$I_2 = \frac{V_C - V_D}{R_2} = \frac{V - 0}{R_2} = \frac{V}{R_2}$$

Therefore,

$$I = I_1 + I_2 = \frac{V}{R_1} + \frac{V}{R_2} = V \left(\frac{1}{R_1} + \frac{1}{R_2} \right)$$

So in this case also, we can define an equivalent resistance R , where

$$I = \frac{V}{R} \quad \text{and} \quad \frac{1}{R} = \frac{1}{R_1} + \frac{1}{R_2}$$

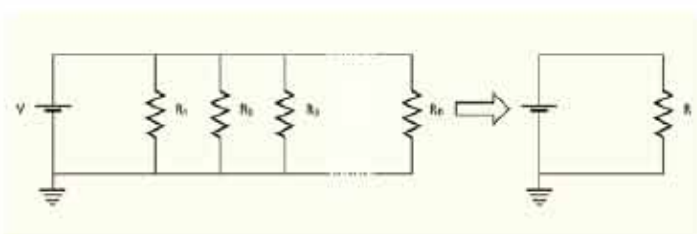

Figure 11.14: Many parallel resistances or resistors can be imagined as a single equivalent resistance or resistor.

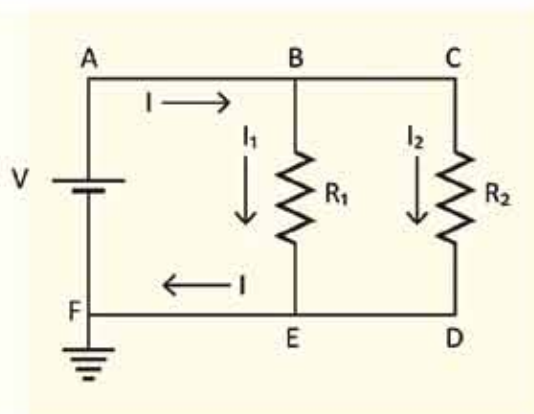

Figure 11.13: Two parallel resistances are shown in a circuit.

If the resistances are more than two (Fig. 11.14) then the equivalent resistance R will be

$$\frac{1}{R} = \frac{1}{R_1} + \frac{1}{R_2} + \frac{1}{R_3} \dots \frac{1}{R_n}$$

11.3 Electric Power

When discussing potential, we saw that if a charge is moved by applying a potential then some work is done or some energy is lost. So if V potential is applied to move a charge Q in a circuit then the amount of work done (or the applied energy) is

$$W = VQ \text{ Joule}$$

Power P is the capacity of work done per second, so if Q charge is moved in t time then

$$P = \frac{W}{t} = \frac{VQ}{t} = VI \text{ Watt}$$

If we use this on a single resistance R , then applying Ohm's law we can write, since

$$V = RI$$

$$P = I^2R$$

or

$$I = \frac{V}{R}$$

therefore,

$$P = \left(\frac{V}{R}\right)^2 R = \frac{V^2}{R}$$

If electricity flows through a resistance for time t , then Pt energy is supplied there. Where does this energy go? When you use a resistance in a circuit and if you pass enough electricity through this resistance, then you will notice that it always gets hot. That means the electrical energy evolves as heat energy.

The use of bulbs with filaments are getting scarce, because the filament has to be heated to create light with this. A big part of the electric energy is used to heat up the filament, and energy is wasted. If we touch these bulbs with our hand we can feel how much heat energy is created, and this energy is created as I^2R or V^2/R in every second.

This is not the only place where the electrical energy is used to create heat

energy. It provides energy for the fan, fridge, television, computer, charger and different types of equipment for different purposes. We can find out how much electrical energy is consumed per second in electrical appliances very easily from VI. Every house has an electric meters. It continuously measures potential (V) and what amount of current is flowing (I). From there it can determine how much electrical energy ($P=VI$) is provided in each second in the house. Multiplying this with the total time we can find the total electrical energy spent. The conventional unit of electrical energy spent is kilowatt-hour (kW-h). This unit is called Board of Trade Unit (BOT) or briefly, Unit. The electric bill we pay is calculated in this unit.



Example

Question: What is the resistance of the filament of a 100 W bulb?

Answer: 100W is written on a 220V bulb, as

$$P = \frac{V^2}{R}$$

Therefore,

$$R = \frac{V^2}{P} = \frac{(220)^2}{100} \Omega = 484 \Omega$$

How much current is flowing here?

$$I = \frac{V}{R} = \frac{220}{484} = 0.45 \text{ A}$$

It can be done in other ways too: $P = VI$

$$I = \frac{P}{V} = \frac{100}{220} = 0.45 \text{ A}$$

Question: If a bulb of 60 Watts is lit everyday for 5 hours for 30 days then what would be the electric energy usage? If each unit has a price of 10 taka, then what will be the total cost for this electricity?

Answer: We know, spent energy = $(P \times t) / 1000$ kilowatt-hour or unit

$$P = 60 \text{ W and } t = 5 \times 30 \text{ hour}$$

$$\text{Spent energy} = 60 \times (5 \times 30) / 1000 \text{ unit} = 9 \text{ unit}$$

Total cost of electricity with 10 taka per unit = $9 \times 10 \text{ taka} = 90 \text{ taka}$

11.4 Electrical Supply

When current needs to be transmitted from one place to another in a country, it is transformed into a very high voltage. This is done to reduce the loss of electricity in electrical wires. You know that, the amount of energy wasted per second as heat energy is equal to I^2R , so we may conclude that there would be no dissipation of energy as heat energy if there was no resistance R in electrical wires.

But that is not practically possible; everything has some resistance. That is why, if current I can be reduced, the energy lost I^2R due to heat can also be reduced. Since the amount of electrical energy supplied per second is VI , if the potential is increased by 10 times, it is possible to supply the same energy using 10 times less current. If 10 times less current is supplied, 100 times less heat energy will be dissipated. This is because the resistance R of the wire is the same in both cases.

Now you may think that the loss of heat energy can also be written as V^2/R and in that case the heat energy loss will be 100 times due to 10 times increase of voltage. It is to be remembered that when we found the energy loss per second as V^2/R , we then saw V was the potential difference between the two sides of the resistance. The V which we are discussing here is not the potential difference between the two sides of the wire. It is the value of potential of the electric wire! The value of the potential on two sides of the electrical wire is almost equal. So the difference is negligible.

11.4.1 System Loss of Electricity

We know that the power plants situated at different parts of the country produce electricity. This electricity is to be transmitted to different of the country. To distribute electricity, first it is transmitted to the substations of different areas. The electrical energy is then distributed to consumers using electricity distribution systems.

The conducting wires that are used to carry electricity from one place to other have at least some minimum resistance. When current (I) flows through a resistance (R), heat (I^2R) is generated and this is loss of electrical energy. This loss is called system loss. We have already discussed that if electricity is supplied at high voltage then for a definite electrical energy, loss is reduced because of resistive heat energy. That is why electricity produced in the power plants is transformed into high voltage using step up transformers. Before distributing the electrical energy for customer use, the electrical supply is again brought down to a suitable voltage using a step down transformer.

11.4.2 Load Shedding

Each power plant produces a definite amount of electric energy and electricity produced in all power stations is added to the national grid. We have discussed earlier that electricity is distributed to consumers from local substations. The national grid supplies electricity as per the needs of different areas. If the demand of electricity in an area is more than the electricity produced, then naturally the required electricity cannot be supplied in that area. Then the substations are forced to keep electricity supply off in one area to be able to supply electricity to another area. This process is called load shedding. When the substation gets the required electricity supply again, it distributes electricity to that area again.

If load shedding is to be done for several hours at a stretch, to make load shedding tolerable, the authority load sheds in a rotation, in different areas at different times.

11.5 Safe Use of Electricity

We cannot think of a moment without electricity. Electricity brings light to our house, keeps us cool in the summer by using fans. We watch television and use computers using electricity. Electricity runs fridges that preserve food. We use it to iron clothes. When the charge of mobiles gets low, we use electricity to charge the battery. Rich people use AC in their houses, washing machines to wash clothes, and electric heaters to cook. They prepare warm meals by heating using microwave ovens.

We can go on telling all day about the uses of electricity in our houses, schools, colleges, fields, farms, industries and hospitals etc. In our country, generally 220V (AC) electricity is supplied, which can give electric shock to people and

may even cause death from those shocks. That is why all electrical appliances are made in such a way that no one comes in direct contact with those things. If electricity passes directly through the heart then only 10 mA of current can cause death. The electricity we use for different purposes is AC, and AC current is 5 times more harmful than DC current. The resistance of dry skin of human beings is around $3,000\ \Omega$ to $50,000\ \Omega$ which decreases by a thousand times when it gets wet. So from Ohm's law we can show that the 220 V electricity of our country can easily produce fatal current flows. A person with a wet feet standing on a wet floor has the worst possible condition of getting an electric shock.

When a person is electrocuted, he can't move hands and legs because of the current flowing through his body. As a result, in spite of having the sense to move away from the dangerous condition, he or she won't be able to do it.

The electricity we use can be dangerous, but if we follow some general precautions we can safely use electricity, and millions of people around the world are doing so. We should know the following for safe use of electricity:

(a) Electrically insulated cover: Open wire carrying electricity is dangerous, so it is always covered with plastic or another insulator. If short circuit occurs for any reason i.e. positive and negative wires touches without any resistance then, according to Ohm's law, a large amount of current flows, the wire become heated, the plastic burns and can even cause fire. So it should be taken care that insulating layer remains unaltered and intact.

(b) Better Connection: The electrical connections should be made correctly where electrical equipment run using huge amount of electricity. If the connections are not properly done, extra resistance is produced and according to I^2R , it may be heated, may burn the insulating layer, and can damage the electrical connection.

(c) Humidity: Water is conductor of electricity, so if water enters any circuit, it may be dangerous due to short circuit. A hair drier or electric iron is very dangerous to use near water, because if it falls suddenly in the water and anyone touches it, an accident may occur by electrocuting the person.

(d) Circuit breaker and fuse: Major accidents of electricity occur when a large amount of current flows suddenly due to some defects. To stop sudden large flows, circuit breakers or fuses are used. A circuit breaker is made in such a way that if a large amount of current flows (more than the safer level), it breaks the circuit. A fuse is a comparatively simple method; the amount of current that

flows through equipment is passed through a thin wire before entering the equipment. The thin wire (where the resistance is more, so I^2R is more i.e. more heat) of the fuse becomes heated and burnt, and stops the supply of electricity if for any reason excess current tries to flow.

(e) **Flow less connection:** There are always two wires in an electric supply line, one with high potential (Live) and another is voltage less neutral (Neutral).

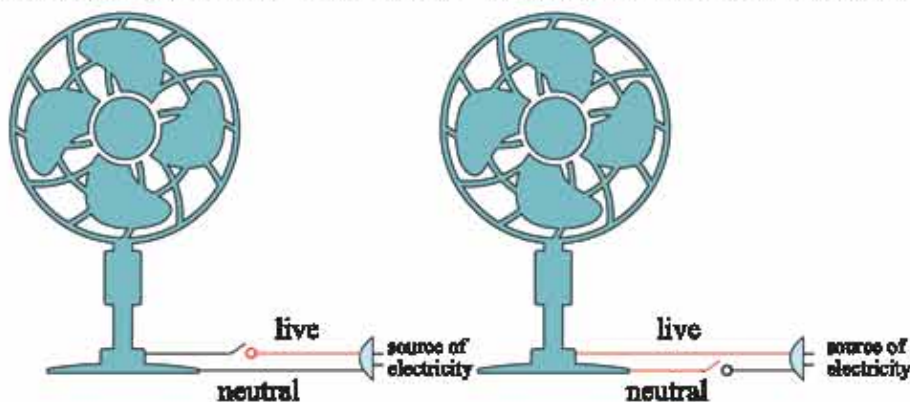

Figure 11.15: Wrong and correct connection of switch.

When a machine is used, then starting from the live wire the electricity passes through the machine and then returns to the source through the neutral wire. A voltage less neutral wire is safe, but a high voltage wire should be used cautiously. When a switch is used to connect electricity to a machine, it can be connected with a high voltage wire or a neutral wire. It is wise to connect the switch with the high voltage wire (Figure 11.15). Then high voltage enters the machine only when the switch is on. When the switch is off, there is no high voltage inside the machine.

(f) **Ground:** You may have noticed that there are at least two connections in an electric supply in school or at home, high voltage and neutral. But if an expensive machine (e.g. computer, fridge) is connected to the current, you will see that besides high potential and neutral, there is another third connection, which is the ground. Generally this is connected to the body or cover of the machine. If the machine is electrified accidentally, then current directly flows from the cover or body to ground. A fuse burns due to this flow of electricity and makes the machine safe. So, if anyone accidentally touches it, he is not electrocuted.



Figure 11.16: Dangerous activities with electricity.



Do Yourself

Make a list of the dangerous activities done with electricity in Figure 11.16.

11.6 Design of Circuit in Residence

What a circuit should be like for supplying electricity in a household is shown in Figure 11.17. Electricity is supplied at home from a power station through a supply cable. Between them, one is live; another is neutral. The live line has high voltage, the neutral has zero voltage. The live line is marked red and the neutral line is marked blue in the figure. It first passes through an electric meter. This meter records how much electricity is consumed. After the meter, it is supplied through a consumer unit.

Three circuit breaker or fuse of 5A, 15A and 30A is shown in Figure 11.17. These three circuit breakers are connected to the main switch. The electric supply of the whole house can be cut off using the main switch.

In the figure, current is supplied to the lights and fan from the 5A circuit breaker. 15A is connected with cooking burner. 30A circuit breaker is connected to the plug points of the house. We have certainly noticed that this part is like a ring which means flow of current can be through two different paths. In this part the ground is shown differently (green color).

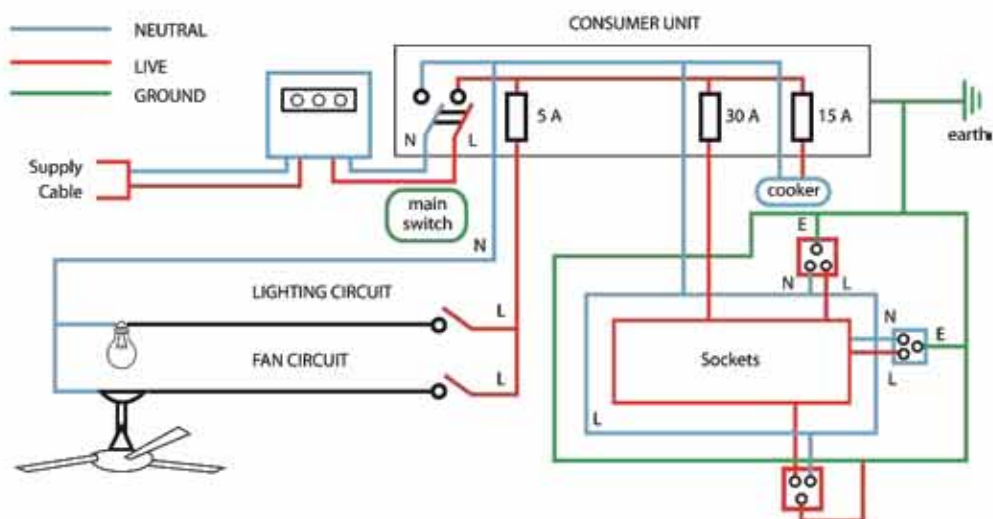

Figure 11.17: Possible circuit for supplying electricity to a house.



Do Yourself

What steps should be taken to minimize the dissipation of electricity? Describe these in a nice poster.

To create awareness among all with the posters, make arrangements to display them.



Do Yourself

Objective: Students will be able to analyze the electric circuit design suitable for use in residence.

Working procedure: A probable circuit for supply of electricity in residence is shown in Figure 11.17. Make a new circuit by doing the following changes in this circuit.

- Add two more plug points since three plug points are not enough.
- Add a water pump with an appropriate circuit breaker which uses electricity.
- Add a second light using two switches in such a way that the light can be turned on or off by using any of the switches along with the light and fan.



Exercise



General questions

- Is it possible to use a capacitor as a battery?
- Why is it difficult to make an experiment to see if the filament of a filament light bulb is following Ohm's law or not?
- Electric current is the flow of electrons. When electricity flows the speed of electrons is comparatively low. But electricity flows instantly-how?
- For equal potential difference, will a high resistance produce more heat or a low resistance produce more heat?
- It is not seen that a crow or a bird dies on an electric cable, but a big bat often dies why?
- What is electric current?

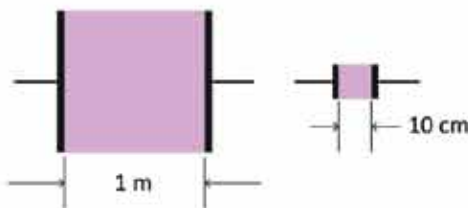
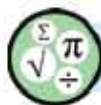

Figure 11.18: Two square resistors of 1 m^2 and 100 cm^2 .

7. What are directions of the conventional current flow and electron flow?
8. What are conductor, insulator and semiconductor materials?
9. State Ohm's law.
10. Show that, $V=IR$.
11. Plot a graph of I versus V on a graph paper.
12. Define specific resistance.
13. Show that, the value of the equivalent resistance of resistors connected in series is equal to the sum of the different resistances included in the combination.
14. What are the causes of using electrical energy that can be dangerous?
15. A current of 2.5 A is flowing through the filament of the headlight of a motor car. If the potential difference between the two ends of the filament is 12 V, what is the resistance?
16. The electromotive force of a dry cell is 1.5 V. What is the energy spent by the cell in driving 0.5 C of charge round the circuit?
17. What are fixed and variable resistors?
18. What do you understand by electromotive force and potential difference?



Mathematical questions

1. Make a $2\ \Omega$ resistor using infinite number of $1\ \Omega$ resistor.
2. Using nichrome sheet of 1 mm thickness, your friend has made a resistor of $10\ \text{cm} \times 10\ \text{cm}$ square (Figure 11.18). You have made a resistor of $1\ \text{m} \times 1\ \text{m}$ square. What is the value of the resistance made by your friend? What is the value of your resistance?

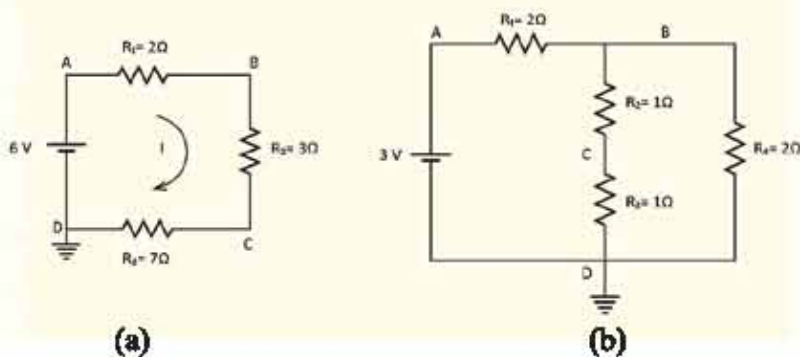

Figure 11.19: Two circuits formed by battery cell and resistors

- If the point D of the circuit shown in Figure 11.19 (a) is connected with the earth, what are the voltages at the points A, B, C and D? What is the value of I ?
- If instead of point D, the point C is connected with the earth of the circuit shown in Figure 11.19 (a), then what is the voltage? What is the magnitude of I ?
- If the point D of the circuit shown in Figure 11.19 (b) is connected with the earth, what are the voltages at the points A, B, C and D?



Multiple choice questions

Put the tick (\checkmark) mark on the correct answer

- What are the materials through which electric current can flow very easily?

(a) insulator	(b) bad conductor
(c) semiconductor	(d) conductor
- If three resistances of values 2Ω , 3Ω and 4Ω are connected in series, then what will be the equivalent resistance?

(a) 8Ω	(b) 7Ω
(c) 9Ω	(d) 20Ω
- The potential difference between the two terminals of a conductor is 100 V . If the amount of current flowing through it is 10 A , what will its resistance be?

(a) 1000Ω	(b) 0.1Ω
(c) 10Ω	(d) none of them
- The electrical condition of a circuit is measured by-
 - Voltmeter
 - Ammeter
 - Generator
 Which one is correct?

(a) i and ii	(b) i and iii
(c) ii and iii	(d) i, ii and iii

**Creative questions**

1. The length and cross-sectional area of a nichrome wire used in an electrical heater, is 20 cm and $2 \times 10^{-7} \text{ m}^2$ respectively. The resistivity of nichrome is $100 \times 10^{-8} \Omega \text{ m}$. The nichrome wire is replaced by a copper wire of identical length and cross-sectional area. The resistivity of copper is $1.7 \times 10^{-8} \Omega \text{ m}$.

- What is resistance?
- Why does the resistance of conductor increase with increasing temperature?
- Determine the resistance of the copper wire.
- Analyze the logic of using copper wire.

2. Alvi uses a bulb of 220V-100W during his studies for 3 hours daily. His brother Alif uses a table lamp of 220V-40W for 4 hours daily. The cost of each unit of electrical energy is 3.5 taka.

- Write down Ohm's law.
- Explain, what will be the change in resistance of a conductor if the length is increased by 5 times (provided that the temperature, material and area of cross-section remain unchanged)?
- Determine the current of the lamp used by Alif.
- Who is more economical, Alvi or Alif (considering money)? Analyze with mathematical arguments.

3. The potential difference of an electric supply line in our country is 220 V. The resistance of the filament of an electric bulb is 484Ω . 220 V- 100 W is marked on the bulb.

- Define ampere.
- What does it mean to say that the electromotive force of a dry cell is 1.5 V?
- If the bulb is connected with the supply line, what will be the electric current?
- Propose an experiment to verify 220 V-100 W marked on the bulb.

Chapter Twelve

Magnetic Effects of Current



The Children are making electromagnet in the largest practical class of the world arranged in Kuliarchar.

All of us were charmed at one point of our life when observing the attraction or repulsion of magnet. Though magnetism and electric current seems to be completely different topics, these are two different forms of the same energy, that will be discussed in this chapter. We will see that as electric current can produce a magnetic field, similarly a varying magnetic field can also produce an electric current.

In this chapter along with the magnetic effects of current, we will discuss how different instruments can be made and can be used by using magnets and electricity.



By the end of this chapter we will be able to-

- explain the magnetic effects of electric current.
- explain electromagnetic induction.
- explain induced current and induced electric power.
- explain the main principles of motors and generators.
- explain the main principles of transformers.
- explain the functions of step-up and step-down transformers.
- understand the various uses and contributions of current in our life.

12.1: Magnet

All of you have seen a magnet. If a magnet is brought close to iron like materials, then it attracts the iron. There is nothing visible between the magnet and iron but an invisible force is pulling it. When observing that for the first time, one kind of surprise is developed in all.

Those of you who have played the magnets must have noticed (Figure 12.01) that there are two poles of a magnet. The similar poles repel, while the dissimilar poles attract each other.

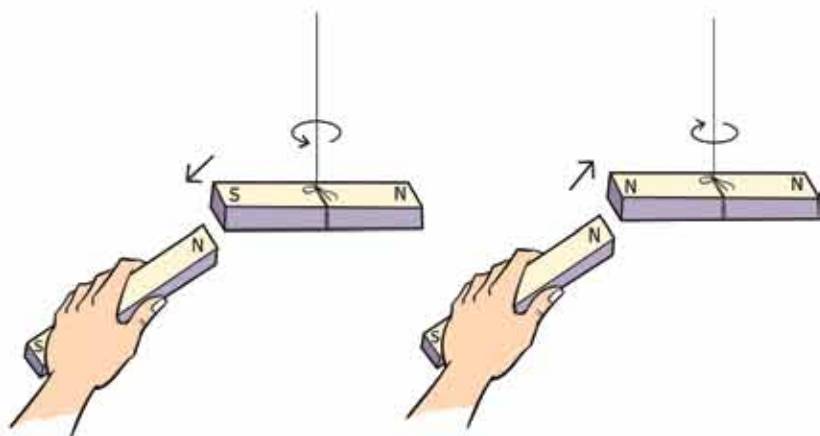

Figure 12.01: Dissimilar poles of a magnet attract, and similar poles repel.

The poles are generally named the north and south poles.

If a bar magnet is suspended freely, it always points towards the north-south direction.

The pole which directs towards the north direction is called the north pole, and the pole which directs towards the south is called the south pole. This occurs due to the fact that the earth itself has a magnetic field; when a magnet is suspended; the magnet aligns itself along that field.

We can discuss how two magnets attract one another. But first we have to know from where the force of a magnet comes.

12.2: Magnetic Effects of Current

Those of you who have handled magnets cannot imagine that it is not different from electricity, and a magnet can be made by electricity or flow of charges!

When a charge is kept in a place, an electric field is produced around it. Similarly, if electric current flows through a wire, a magnetic field will be created around it.

Let us assume that a wire penetrates through the middle of a cardboard and some small compasses are placed on the cardboard around the wire. The compasses will be aligned along north-south direction. Now if a current (moderately strong) passes through the wire, you will surprisingly notice that suddenly the compasses are arranging themselves one after another. You will get an impression that a circular magnetic field around the wire has been generated due to the electric current.

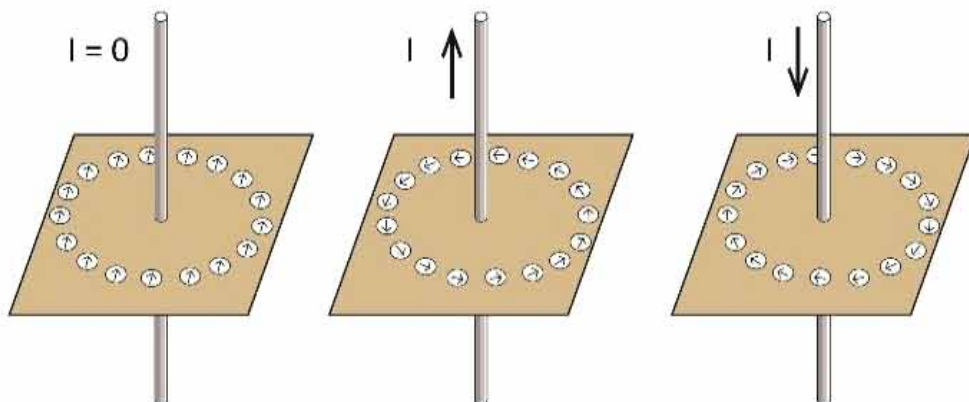

Figure 12.02: Directions of the compasses around electric current

Now, if the current is stopped, then again the compasses align along the north-south direction. If the direction of current is changed, you will find that the compasses will arrange themselves again, but now the direction of the compasses in the circle will be reversed. This is because the current always produces a magnetic field around it in a definite direction.

If current flows through a conducting wire, then the direction of the magnetic lines of force produced due to this can be obtained from the right hand rule. If the thumb indicates the direction of current, then the other fingers will indicate the direction of the magnetic field (Figure 12.03).

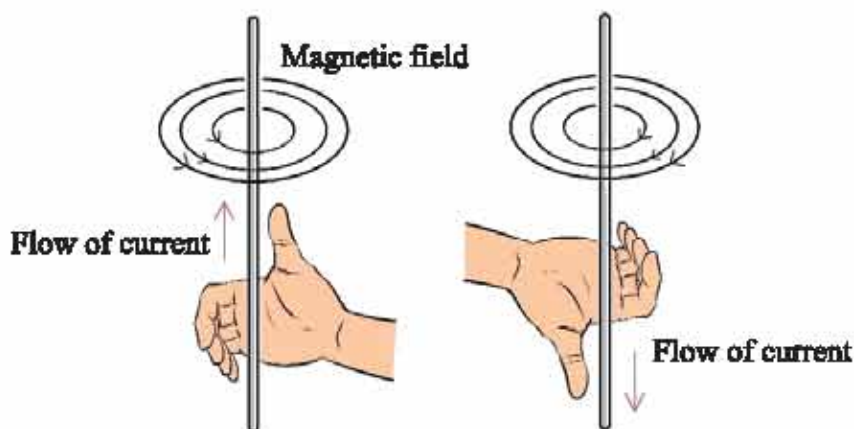

Figure 12.03: The magnetic field around the electric current. Magnetic field has no beginning or ending.



Example:

Question: Figure 12.04 shows that current is flowing upwards from inside the book. Which of the magnetic fields is correct?

Answer: The left figure is correct.

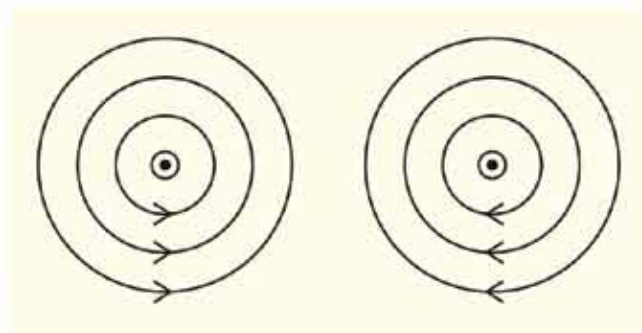

Figure:12.04: Magnetic field around the current carrying wire

12.2.1: Solenoid

If a wire is straight and current passes through it, then

the nature of the magnetic lines of force was shown in Figure 12.03. How will it be the magnetic lines of force if the wire is circular instead of being straight? This is shown in Figure 12.05. You are able to understand that the more the current, the stronger the magnetic field is. There is a limit to how much current can be pass through a wire, since the wire is heated as I^2R . Moreover, the maximum amount of current that can pass through a wire depends on the source of electricity. Therefore if we want to produce a strong magnetic field, then instead of making a single loop, a coil is made by a insulated wire, winding it

several times. This coil is called a solenoid. A strong magnetic field can be generated by that coil. Every loop of the coil will create a magnetic field due to the electric current flowing through it. So the combined magnetic field is stronger.

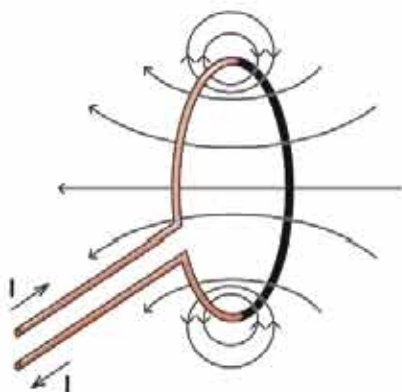

Figure 12.05: Magnetic field produced due to current flowing through a loop.

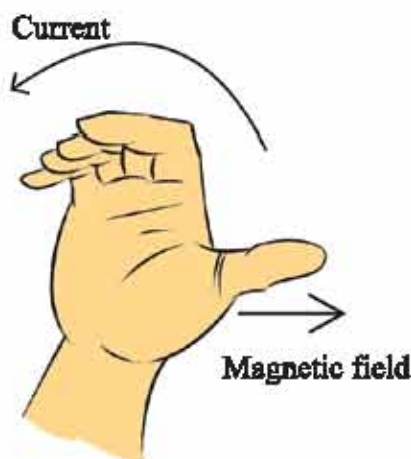

Figure 12.06: Direction of the magnetic field (applying right hand rule) due to the current through a loop.

If current flows through a circular coil, then the direction of its magnetic field can also be found with the help of the right hand rule. The thumb indicates the direction of the magnetic field, while the other fingers show the direction of the current (Figure 12.06). A coil of wire or a solenoid behaves like a bar magnet, and the direction of the thumb will be the north pole of this magnet.

12.2.2: Electromagnet

A more powerful magnetic field can be created if a piece of iron is inserted inside a solenoid than the magnetic field that can be produced by using current only. The three metals iron, cobalt and nickel have special magnetic properties. These metallic pieces can be considered as an accumulation of individual tiny magnets, which generally don't act as a magnet as they are aligned in different directions. These substances consist of an enormous number of small magnets that are randomly oriented. Since the small magnets are randomly oriented, the piece of iron does not act as a magnet.

But when this piece is kept inside a solenoid or a coil, and if current is passed through the solenoid, then the magnetic field produced by that current aligns the individual tiny magnets.

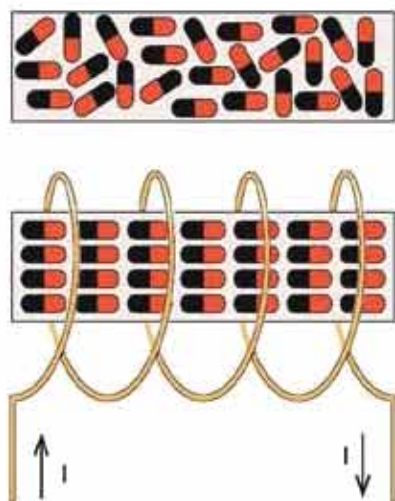

Figure 12.07: Strong magnetic field is produced when randomly oriented small magnets get aligned due to flow of current.

12.2.3: Effect of Magnet on a Current Carrying Wire

We know that the opposite poles of two magnets attract each other and the similar poles repel. We also know that a current carrying wire generates a magnetic field around it. If we place a wire in a magnetic field and current is allowed to flow through this wire, then due to the creation of magnetic field by the current, it will experience a force. In Figure 12.09, magnetic lines of force from the north pole of a magnet to the south pole, and a current carrying wire placed between the poles is shown. The wire comes out perpendicularly from inside the paper.

Therefore, the magnetic field produced by the current and the magnetic field produced by the iron piece itself combine to produce a strong magnetic field (Figure 12.07). The interesting point is, as the current is stopped, the small magnets present within the iron piece become randomly oriented again, and the entire magnetic field will disappear.

A magnet prepared by this process is called an electromagnet. Uses of electromagnets are endless, Such as in the sound we hear in speakers and earphones (Figure 12.08).

Here, according to the vibration and intensity of sound, current is sent. That current produces an electromagnet according to the vibration and intensity of the sound. This electromagnet vibrates a diaphragm and produce the sound.

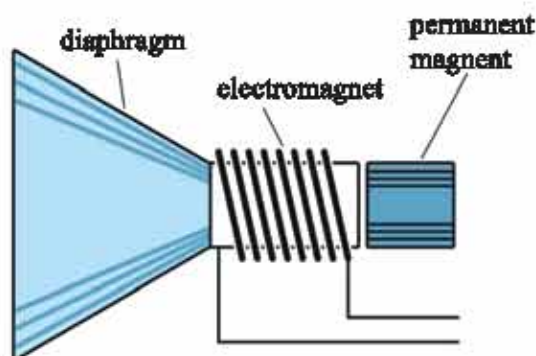

Fig:12.08: Electromagnet is used in speaker

If current flows through the wire (from bottom to up) that current will create a circular magnetic field around it and thus rearrange the magnetic lines of force, by combining with the magnetic field that goes from the north pole to the south pole. At the bottom of the wire the lines of forces will be more and at the top of the wire the lines of forces will be less, which will push the wire in upward direction.

If the direction of current through the wire is reversed, then the direction of the circular magnetic field will also be reversed. Then the density of the lines of force at the top of the wire will be more and hence push the wire downward.

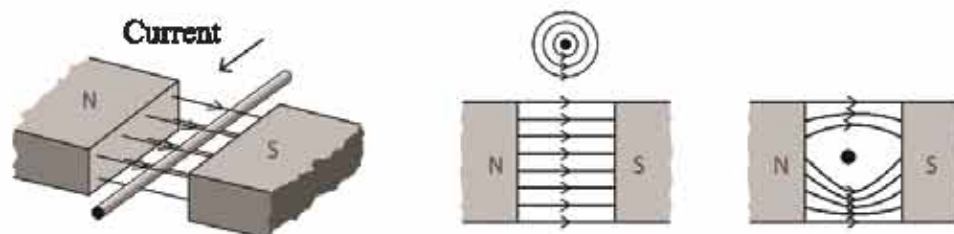

Figure 12.09: A current carrying wire placed in a magnetic field experiences a force.

12.2.4 D.C Motor

You know that a magnet can be used to apply force on another magnet. In other words, we can say a magnetic field can be used to apply force on another magnetic field. Since a wire cannot carry very much current, it cannot produce a strong magnetic field. That is why with the help of another magnetic field a strong force cannot be applied on it. You have seen that if a coil of wire is made winding many times and a piece of iron or armature is inserted into it, then by passing a little amount of current through the wire, the coil becomes a strong electromagnet that can create a very strong magnetic field. If we imagine the coil is to be a bar magnet, and keep it in another magnetic field, then we can analyze what kind of attractive or repulsive force it feels and also the direction of motion due to it. In Figure 12.10, an electromagnet of this type is placed in another magnetic field, and how it changes its position due to the repulsive force is shown. If the electromagnet is allowed to rotate about an axis, passing through its center, then it will try to go to a position like in the next figure.

If we can make such a condition that as soon as the electromagnet reaches the next position, the current passing through the electromagnet is changed, then just after reaching there, the bar magnet made of coil alternates its polarities,

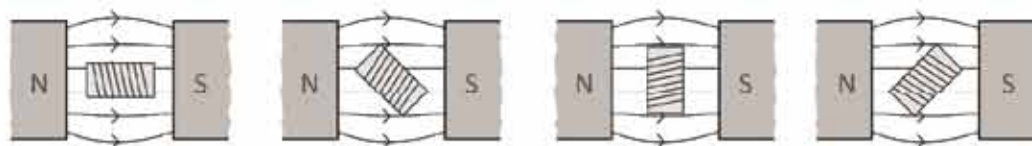

Figure 12.10: In an electric motor current is passed through an electromagnet in such a way that it can rotate always.

i.e. its north pole becomes the south pole and the south pole becomes north pole. So due to repulsion, it will try to move again, i.e. it will experience a rotational force. It will try to reach the next stable position, but just after reaching there if the direction of the current is again changed, it will not stop there. Rather, it will continue its rotation. That's why, when it reaches one stable position, if current

in it flows in such a way that it experiences a rotational force due to repulsion, then it will continue to rotate.

In order to change the direction of current, we have to use a mechanical technique with the help of a simple device called a commutator. The two wires of the electromagnet are placed on two sides of the rotating axis around which the main coil rotates in such a way that it touches two terminals of the main electric current at the commutator. When the terminals touch it, then it will flow the current in such a way that it tries to move away the electromagnet always by repulsion. When it moves away from the terminals of the main current, no current flows in the electromagnet, then it continues its rotation due to inertia of motion.

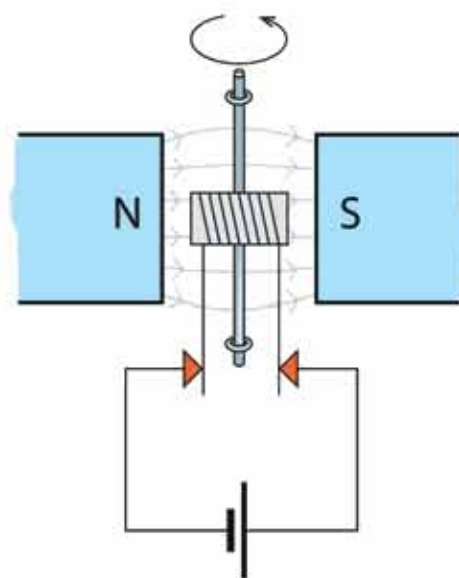

Figure 12.11: An electric motor.

For your understanding, it is presented in a easy way (Figure 12.11). In a practical motor, there may be many coils around the armature and each coil gets current from the commutator and the armature continues its rotation.

12.3 Electromagnetic Induction

We see a lot of machines that rotates around us, it may seem to us that this is the magnet and the biggest contribution of the magnetic field! Actually the biggest contribution of magnets and magnetic fields is electromagnetic induction, that is, the production of electricity with the help of magnetic fields.

Scientist Oersted first showed that if the magnetic field is changed through a conducting loop, then an electromotive force is developed within the loop, which can flow current through the loop. This property is used to build an electric generator, where by changing the magnetic field through a conducting loop, generates electricity.

If the two ends of a coil are connected with an ammeter and a bar magnet is inserted in it, then at the time of inserting the magnet we will see a sudden flow of current in the ammeter (Figure 12.11). When we will pull it out, again we will see a sudden flow of current in the ammeter, but now in the opposite direction. If we change the pole of the magnet, then we will see the change of direction of current in the ammeter also! During the time of changing the magnetic field in a coil of wire, the generation of voltage and current in the coil is called electromagnetic induction. This voltage is called induced voltage, and the current is called induced current.

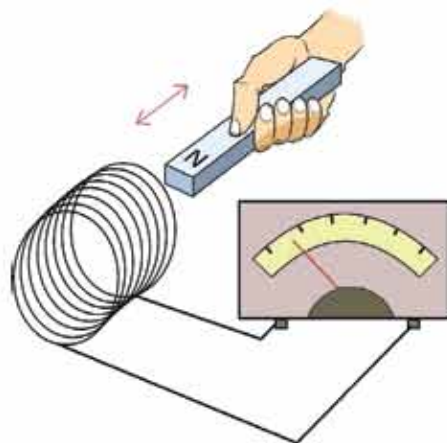

Figure 12.12: When a magnet enters into a solenoid current is produced in it.

During this experiment, to change the magnetic field in the coil, we brought the magnet towards the coil away from it. If we could change the magnetic field in an other way, then we would observe the same thing.

Another way of changing the magnetic field in the coil is to bring another coil near it (instead of bringing the magnet) and producing magnetic field in the second coil by flowing current through it. If a battery and a switch are connected with the second coil to produce magnetic field in it, then by turning the switch 'on', a magnetic field can be produced in the coil, again turning the switch 'off', the magnetic field can be removed. Keeping the second coil near the first coil, if a magnetic field is produced once in it and the magnetic field is removed again, then the magnetic field will be changed in the first coil and due to this we will see current in the ammeter! When current is produced by turning on the switch, then the ammeter will show the presence of the current by deflecting its needle in one direction. When the switch is turned off, the needle will deflect in another direction, and show the current flowing in the opposite direction.

One thing we have to remember: when the magnetic field changes, only then does the current flow. If a strong magnet is kept inside a coil, no current will flow through the coil. Only by moving the coil, the magnetic field is changed, then a current will flow through it.

12.3.1 Generator

When we were trying to understand how a motor works, we saw that a current passes through an electromagnet in a magnetic field which cause it to rotate. Let us see the matter in another way. If instead of giving connection of a battery cell with two terminals of an electromagnet of a motor, we connect an ammeter there and rotate the electromagnet. What will happen then?

Of course, the magnetic field within the coil will change, so a current will flow through the coil. That is, the electromagnet of the motor that we have rotated by passing current through it, if we rotate that electromagnet or coil, the reverse thing happens, electricity is generated. In this way a generator is built. Therefore, if we rotate the armature of a DC motor, we get DC electric current, if AC motor is rotated it gives AC current.

12.3.2 Transformer

Changing a magnetic field creates current— this property is used to prepare transformer. In Figure 12.13 a rectangular iron core is shown to understand how a transformer works. Conducting wires have been winding on the two sides of the core— of course there are insulating covers on the conducting wires, so that if it touches anything metallic a short

circuit doesn't occur. In the figure, we see that on the left side of the core an AC voltage source is connected. Since the wire is connected by winding the iron core, so when current will flow the core will be magnetized and the magnetic lines of force will pass through the rectangular iron core.

Since we have connected AC voltage source, the magnetic strength inside the core will increase or decrease and will change its direction, i.e. the magnetic field will change continuously. On the other side of the iron core, there is wire winding also (definitely covered with insulator). The magnetic field will change continuously in that coil through the iron core, and this change will produce an electromotive force (emf) in the coil of the right side. If we wish, we can see it in a voltmeter. The transfer of electricity from one coil to another coil in this process (directly, without any electrical connection) is called transformer.

We can do some amazing things with this transformer. If the number of turns of both the coils is the same, then for a definite AC voltage applied in the left side coil, we will get the same AC voltage in the right side coil. If the number of turns on right side is ten times of that of the left side, then the voltage becomes ten times. If the number of turns on the right side is ten times less, then the voltage will be ten times less. The coil on the left side where AC voltage is applied is called the primary coil and the right side coil (from where voltage is returned back) is called the secondary coil. You may think that if it is possible to be happened, then why don't we arrange an enormous amount of electrical energy by giving small numbers of turns and applying small voltage in the primary coil and by giving much more turns in the secondary coil, and thus obtaining a much higher voltage? We have to remember one thing: the amount of electrical energy applied per second is measured by the formula VI (voltage \times current). The

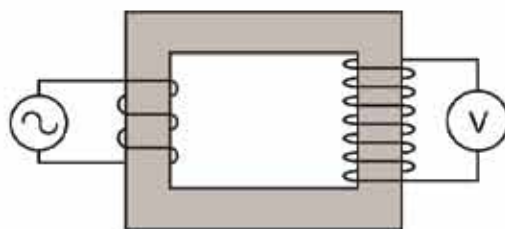

Figure 12.13: If AC potential is applied in primary coil of a transformer, it produces potential in the secondary coil

amount of VI that is applied in the primary coil is just equal to the amount of the VI that we get back from the secondary coil. Therefore, if the voltage is increased by ten times in the secondary coil, then the current in the secondary coil will be reduced by ten times.

For your understanding, a rectangular core is shown. Practical transformers are constructed a bit differently, the secondary coil is wound on the primary coil and the core is also slightly different.

If the number of turns in the primary coil is n_p and that of the secondary coil is n_s , if AC voltage V_p is applied in the primary coil, then the AC voltage V_s that will be found in the secondary coil will be:

$$V_s = \left(\frac{n_s}{n_p}\right) V_p$$

If I_p current flows through the primary coil, then the current I_s flowing in the secondary coil will be,

$$I_s = \left(\frac{V_p}{V_s}\right) I_p = \left(\frac{n_p}{n_s}\right) I_p$$

The transformer has a greater number of turns in the secondary coil than the primary coil and due to this, the AC voltage applied in the primary coil increases in the secondary coil is called a step-up transformer. For transmission of electricity, a step up transformer is used to increase the voltage by many times. The transformer which has less turns in the secondary coil than the primary coil and due to this, the AC voltage applied in the primary coil decreases in the secondary coil. This is called a step down transformer.



Example

Question: The number of turns in the primary coil of a transformer is 100 and the number of turns in the secondary coil is 1000. 10 V DC is applied in the primary coil. What is the voltage in the secondary coil?

Answer: Zero. Transformer does not work with DC voltage.

Question: The number of turns in the primary coil of a transformer is 100 and the number of turns in the secondary coil is 1000. 12 V AC is applied in the primary coil. What is the voltage in the secondary coil?

Answer: $V_S = \left(\frac{n_S}{n_P}\right) V_P = \left(\frac{1000}{100}\right) \times 12V = 120V \text{ AC}$

Example: In the above transformer, if 1A current flows through the primary coil, what is the maximum current that will flow through the secondary coil?

Answer: $I_S = \left(\frac{V_P}{V_S}\right) I_P = \left(\frac{12}{120}\right) \times 1 \text{ A} = 0.1 \text{ A}$



Exercise



General questions

1. If you send an electron beam from one end to the other end of your room and see that it is going upward, what explanation will you give?

2. While making an electromagnet, an insulated wire is wrapped around an iron bar. Is it better to use a single turn with a thick wire or many turns with a thin wire? Why?

3. Between two iron bars, one is a magnet and the other is not. Without hanging or without using any instrument, can you identify which one is iron and which one is magnet?

4. Earth is a huge magnet. Is the north pole of the earth the north pole or the south pole of that magnet?

5. Electricity is produced by moving the magnet, it always tends to oppose the change. Remembering this, if the magnet shown in Figure 12.14 is raised upward, then in which direction will current flow in the loop?

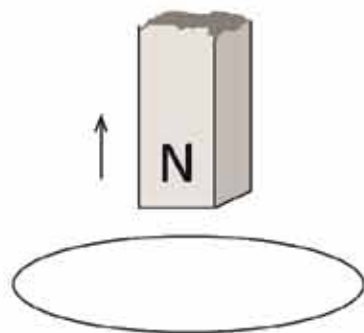

Figure 12.14: Change of position of a magnet inside a loop.

6. What is magnetic effect of electric current?
7. What is an electromagnet?
8. What is a generator? What are the functions of generator?
9. What is the difference between a generator and electric motor?
10. What are the functions or activities of step up and step down transformers?
11. How can the intensity of electromagnet be increased?
12. A transformer is connected with a 240 V AC source. The number of turns of its primary and secondary coil are 1000 and 50 respectively. What is the voltage of its secondary coil?



Mathematical questions

1. Due to the flow of I amount of current through a coil having 10 turns made of an insulated wire, a magnetic field B is produced. What will be the magnetic field if the number of turns is 100?
2. In the above case, to increase the number of turns by 50 more, if by mistake 50 turns are given in the reverse direction, what will be the magnetic field?

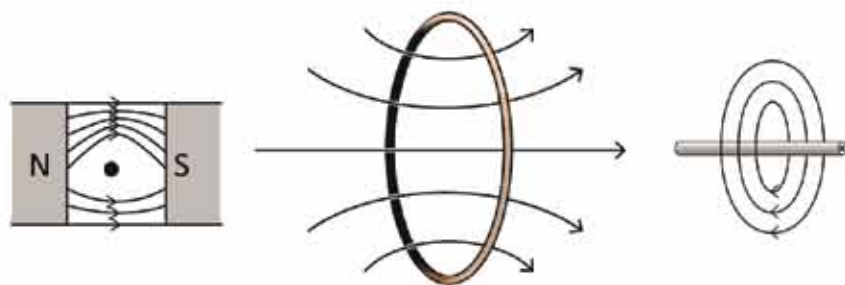

Figure 12.15: Magnetic field around a current carrying wire

3. By observing the Figure 12.15, in which direction is the current flowing in each wire?
4. The number of turns in the primary coil of a transformer is 100, here by applying 15 V AC in the primary, 150 V AC is obtained in the secondary coil. What is the number of turns in the secondary coil?

**Multiple choice questions**

Put a tick mark (✓) beside the correct answer

1. What will happen to the magnetic field if electric current flows through a solenoid made by insulated wire wound over a cylinder?

- a) Will be condensed and weak
- b) Will be condensed and strong
- c) Will be less condensed and weak
- d) Will be less condensed but strong

2. In which of the following functions is, electromagnetic induction used?

- (a) Transistor
- (b) Motor
- (c) Amplifier
- (d) Transformer

3. In which of the following process is, electromotive force produced-

- i) If any magnet is kept motionless in a wire coil
- ii) If any wire coil is rotated in a magnetic field
- iii) If any magnet is rotated around a motionless wire coil

Which one is correct of the following?

- (a) i
- (b) ii
- (c) i and ii
- (d) ii and iii

A bar magnet is moving to and fro through a coil of wire. As a result, voltage is induced in the coil. The induced voltage depends on some factors. Now, answer questions number 4 and 5.

4. In case of electromagnetic induction, the induced voltage depends on which of the following?

- (i) Intensity of the magnetic field associated with the coil
- (ii) Resistance of the coil moving in the magnetic field
- (iii) Speed of the coil moving in the magnetic field.

Which one of the following is correct?

- (a) i
- (b) ii
- (c) i and ii
- (d) ii and iii

5. What will happen to the induced electric current, if the number of turns of the coil is increased?

- The electric current will be reduced
- The electric current will be increased
- The magnitude of electric current will be zero
- The magnitude of electric current will be negative



Creative questions

1. Answer the following question based on the diagram:

- What is the name of the object marked A?
- Explain the principle on which this machine has been made.
- Calculate the electric current in the primary coil of this device.
- Explain the function of this device mathematically on the basis of data.

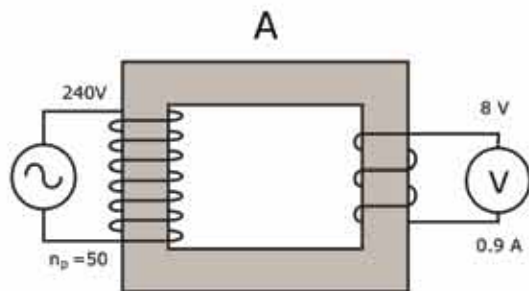

2. A straight long wire is passed through a large piece of paper perpendicularly and connecting a 1.5 Volt pencil battery with it, current is flown through the wire and some iron dust is spread on the paper.

- What is the magnetic effect of current?
- How will the iron dust get arranged on the paper?
- What changes are to be made to the structure of the wire to increase the intensity of the induced magnetic field? Elaborate.
- Analyse the phenomenon that will happen if the wire is wrapped around an iron nail and if one end of the iron nail is taken near to the iron dust?

Chapter Thirteen

Modern Physics and Electronics

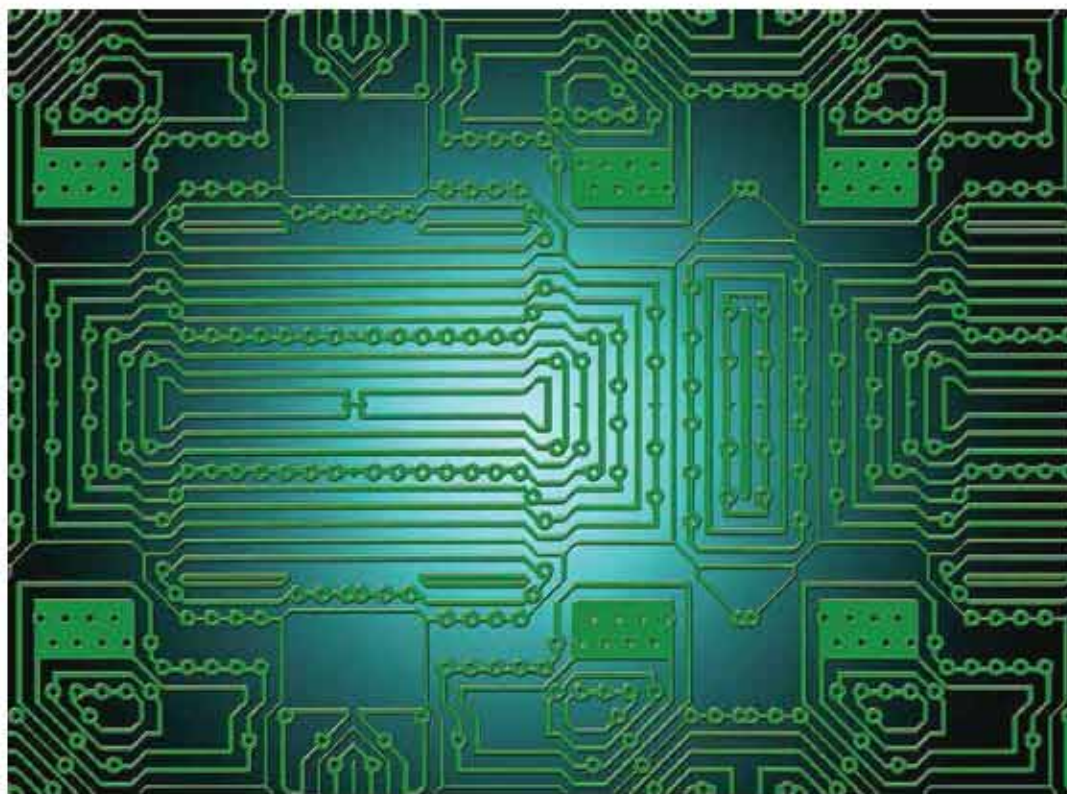

Radioactivity is one of the new topics that have flourished after the emergence of modern physics at the beginning of twentieth century. Radio activity is described in this chapter.

Electronics is the main drive of our present civilization- this statement is not exaggerated at all. The contribution of physics behind the present electronics has been discussed in this chapter, and the instruments that have changed our lives completely have been introduced .



By the end of this chapter we will be able to-

- explain radioactivity.
- explain the characteristics of alpha, beta and gamma rays.
- describe the sequential development of electronics.
- differentiate between analogue and digital electronics.
- explain semiconductors and integrated circuits.
- explain the function of microphones and speakers.
- explain the principles of the function of selected communication technology devices.
- explain the communication process with the help of internet and e-mail.
- investigate how information and communication technology devices influence our life.
- be conscious about how to make proper and effective use of information and communication technology devices and raise consciousness among others.

13.1 Radioactivity

We all know, there is a nucleus at the center of an atom, and there are protons and neutrons in the nucleus. The number of revolving electrons around the nucleus is equal to the number of protons in it. The radius of the nucleus is about one lakh times smaller than the radius of the atom. But the actual mass of the atom is the mass of its nucleus even though its size is small, because the mass of the electron is 1800 times less than that of the proton or neutron.

A proton is positively charged, so the nucleus cannot be formed only with protons because the protons will be thrown off due to strong repulsion force. So there is charge-less neutrons with protons in the nucleus, and nuclei become stable due to very strong nuclear force between neutrons and protons. Though there is only one proton at the center of a normal hydrogen atom, there are also hydrogen nuclei with one or two neutrons.

With the increase of the number of protons, to keep this nucleus stable, the number of neutrons also increases. But when the proton number exceeds 82, the nucleus starts to become unstable. These unstable nuclei try to become stable by emitting a kind of radiation. We call this process radioactivity. The radiation that comes out from the nucleus is called a radioactive ray.

It is not the fact that when proton number exceeds 82 (atomic number more than 82) only then the nucleus becomes radioactive. Any nucleus of other atoms may be radioactive too. We have classified atoms on the basis of their electron number which is equal to the number of protons. External properties, nature, chemical properties; every feature of an element depends on the classification of electrons. So the number of neutrons of an atom can be different even if the number of electrons and protons is equal. These types of elements, with different numbers of neutrons, are called isotopes of that element. So, an isotope of an element may be stable, but another isotope of that element may be unstable or radioactive. For example, we can say that element carbon in whose nucleus there are six protons and its three isotopes are:

C_{12} : 6 protons and 6 neutrons

C_{13} : 6 protons and 7 neutrons

C_{14} : 6 protons and 8 neutrons

Among these three isotopes, C_{14} is unstable or radioactive.

In 1896, Henry Becquerel discovered the existence of radioactive rays from Uranium for the first time. Later on, Ernest Rutherford, Pierre Curie, Marie Curie and other scientists discovered radioactivity of other elements. Since radioactivity it is not influenced by external pressure, heat, electric or magnetic field, and cannot be controlled, it is accepted as a nuclear phenomenon. Due to radioactivity, radioactive rays emerge and this changes the structure of the nucleus and turn it into a different element, this is also observed.

The main three radioactive rays that emit from the nucleus are alpha, beta and gamma rays (Figure 13.01).

13.1.1 Alpha ray

Alpha ray or alpha particle is actually a helium nucleus. A helium nucleus contains two protons and two neutrons, so it is a charged particle. So its path of motion can be influenced by electric and magnetic field. When an alpha particle emits from a nucleus, it possesses some MeV of energy, so when it passes through air and collides with the molecule -atoms it can ionize them intensively. In air, the path of motion of an alpha particle is straight. Since an alpha particle is a helium nucleus, it cannot travel far through air. It loses its energy by ionizing air molecule-atoms and travels approximately 6 cm through air before stopping. An alpha particle can be stopped by using a sheet of paper. It creates phosphorescence on zinc sulfide screen. An alpha particle creates many free electrons by ionizing molecule-atoms of air in its path of motion. Its presence can be detected or its energy can be measured easily by collecting these free electrons.

When a alpha particle comes out from a larger radioactive nucleus then this nucleus's atomic number will be reduced by two and its nucleon number will be reduced by four, because an alpha particle consists of two protons and two

neutrons. For example: an isotope of uranium turns into thorium by emitting an alpha particle.



The atomic number of uranium is 92 and thorium is 90. It is notable that number of electrons of an atom is not significant. Radioactive nuclei of atoms can easily give up or receive extra electrons to and from its surroundings.

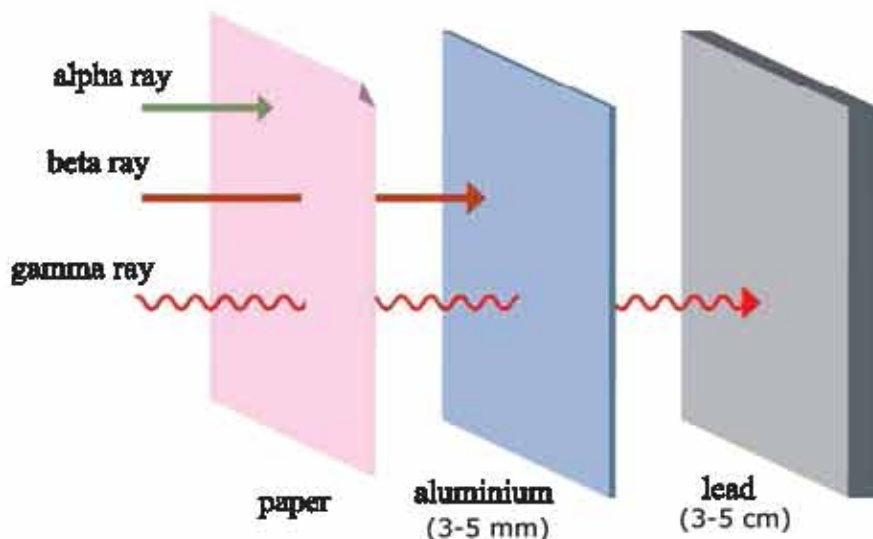
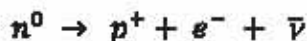

Figure 13.01: It is possible to stop an alpha particle by a single sheet of paper, because it can lose its energy by too much ionizing. It is necessary to stop beta ray or electrons using an aluminum sheet of a few millimeter thick. A thick lead sheet is needed to stop gamma ray.

13.1.2 Beta ray

A Beta particle is actually an electron (it is of course a matter of wonder that a nucleus is consists of neutrons and protons only, so how does an electron come out from a nucleus?) For this, inside the nucleus a neutron has to dissociate into a proton and an electron.



That is, a charge-less neutron is converted into a positively charged proton and a negatively charged electron, so the total amount of charge remains unchanged. In the right side of the equation, ($\bar{\nu}$) indicates the anti particle of a neutrino (anti-neutrino), a mysterious particle of the world of physics, which is chargeless and its mass is very small.

When an alpha particle is emitted from a nucleus, it comes out with a definite amount of energy. But in the case of a beta particle, this is not true. The energy of the beta particle depends on the part of the total energy radiation received by the anti-neutrino.

Since a beta particle is negatively charged electron, it can be influenced by electric and magnetic field. When it passes through matter, it can ionize the molecule-atoms of the matter due to collision with them. Since the size of a beta particle is much smaller than that of an alpha particle (helium nucleus), its penetrating capability is more than the alpha particle and it can penetrate deeper into matter. It is possible to stop a normal beta particle by a few millimeter thick aluminum sheet.

When radiation of beta particles occurs, a proton is increased in the nucleus by deducting of a neutron. So the number of nucleons remains the same. As the atomic number depends on the number of protons, the atomic number of the nucleus increases, and hence a different nucleus of a different element is formed. For example: radioactive C_{14} is converted into N_{14} due to beta radiation:

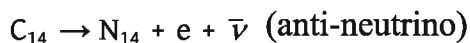

An interesting matter is that, not only the emission of electrons is beta radiation from inside the nucleus; the emission of an anti-particle of electron (positron) is also called beta radiation. For this reason, a proton has to be converted into the neutron inside the nucleus:

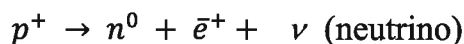

(This reaction cannot take place outside the nucleus. This is because the mass of a neutron is more than that of a proton.)

In this process, the number of protons decreases by one and hence the atomic number also decreases by one, and a nucleus of different element is formed.

Though neutrinos or anti-neutrinos are emitted during beta radiation, they are not considered to be radioactive rays. This is because they are charge less and they are so inert (or nonreactive) that even a few light years thick lead sheet cannot stop a neutrino particle.

13.1.3 Gamma ray

A gamma ray is actually an energetic electromagnetic wave. It has no charge, but as it is strong, its wavelength is very low (frequency is very high). Regardless of the energy of the gamma ray, its velocity is equal to that of light. When a nucleus

becomes excited by radiating alpha or beta particle then extra energy comes out as gamma ray and the nucleus de-excites. A gamma ray is charge less and mass less, so the atomic number or nucleon number of a nucleus does not change due to this radiation.

Since gamma ray doesn't have any charge, so it cannot be influenced by an electric or magnetic field. Because it is charge less, it cannot directly ionize atoms or molecules, but the electrons can ionize atoms or molecules in different processes and from that we can understand the presence of gamma ray. To stop gamma rays with energy equal to that of alpha and beta particles, a thick layer of lead of several centimeters is needed.

13.1.4 Half Life

It is not possible to say the exact moment when a definite radioactive nucleus will emit radioactive rays. Physics can only predict the probability of its radiation. So the concept of Half Life is used to determine the amount of radioactivity. The time in which half of the nucleus disintegrates (or radiates) is known as half life. Therefore, the more the radioactivity of an element, the less its half life is. The half life of a stable nucleus having no radioactivity can be considered to be "infinity".

It is necessary to know that radioactivity is a nuclear phenomenon, so a nucleus is transformed into another through radioactive emission. A different nucleus can accept or donate one or two electrons from the surroundings to become a charge less atom. This is because the energy of the electrons of an atom is much smaller than the nuclear energy of a nucleus.



Example

Question: The half life of a radioactive element of 1 kg is 100 years. What will be its mass after 200 years?

Answer: Mass does not change directly due to radioactivity. Only three fourth of the nuclei of the radioactive element will emit radioactive particles in 200 years.

13.1.5 Uses of Radioactivity

There are many different uses of Radioactivity. If a small amount of radioactive sample is inserted into the body, information about the body can be detected by observing the movement of the radioactive sample from outside the body. Generally those radioactivity samples have a very low half life, it may a few minutes, thus the radioactivity of the samples will be finished within an hour.

Another important use of radioactivity is the determination of the age of ancient fossils. In our body there is huge amount of carbon in which a definite amount of C_{14} is present. When an animal dies, no more C_{14} can enter the body further. The amount of carbon deposited before gets less due to the half life. Thus knowing the amount of C_{14} that would have normally been present initially, and by calculating the amount which is decayed, age can be determined accurately.

A radioactive element can cause harm to the cells of the body, so different types of caution are taken. Radioactivity is used to destroy harmful cells within the body. This is why, for the treatment of cancer radioactive elements are used to destroy cancer cells.

Radioactivity is also used to make the equipment germ free, detecting the presence of smoke and determining the amount of different metals in minerals.

13.1.6 Cautions about Radioactivity

A high radioactive dose can cause many problems in our body. When research started about radioactivity, the scientists did not know the bad effects of radioactivity. As a result, scientists were attacked with many diseases as they came close contact with radioactivity. Due to working for a long time with radioactive elements Marie Curie suffered from leukemia and died. Radioactivity decreases immunity against disease, preventing capability of human and even physical disable children are born inherently.

We do not usually face radioactivity often in our daily life. Due to new



Figure 13.02: Radioactive materials are used very carefully because they are very dangerous.

technology in the world, many people have started to face the bad effects of radioactivity. The nuclear reactions in a nuclear power plant produce serious radioactivity. Many radioactive wastes have high half life and can remain radioactive for lakhs of years. There are even incidents of radioactive wastes being spread into the surroundings due to accidents in nuclear power plants. Many people faced radioactivity in the accident of a submarine run by nuclear energy. The most devastating event took place in Hiroshima and Nagasaki due to nuclear bombs. Many people were exposed to radioactivity. So, many researchers have been started becoming concerned about radioactivity and the determination of the safe limit of radioactivity is also started. General people are now being warned about the effects of radioactivity (figure 13.02).

13.2 Development of Electronics

Electronics has a greatest contribution in the development of the modern civilization and it is not an exaggeration by any means. The gradual development of electronics can be divided into three parts, the vacuum tube, transistor and integrated circuit.

13.2.1 Vacuum Tube

In 1883 Edison observed that in a light bulb, a current can flow through a vacuum space from the filament to a metal plate. This process is known as the Edison Effect. In 1904, John Fleming (on the basis of the Edison effect) first created a vacuum tube with two electrodes, which worked as a rectifier i.e., it converted an alternating current into a direct current. This vacuum tube is considered as the introduction to electronics. At that time the exchange of information was started by radio waves. Guglielmo Marconi needed such type of vacuum tube to control of the radio waves. (It is noted that Marconi was mentioned as the inventor of radio, but in recent times the contribution of Bengali scientist Jagadish Chandra Bose is also acknowledged.)

In 1906 Lee De Forest invented another vacuum tube by adding a third electrode, which is known by the name triode. This triode can control the flow of electricity and worked as an amplifier.

The development of vacuum tubes take place first through telegraph



Figure 13.03 : Types of vacuum tube

communication using Morse code and then through the use of vocal communication by telephone (Figure 13.03). During the first and second world war, different types of specialized vacuum tubes were used in controlling weapons, radar, navigation etc. In 1946 the first computer ENIAC was invented using 1800 vacuum tubes.

13.2.2 Transistor

In 1947 the Transistor was first invented in Bell Laboratory and for this invention John Bardeen, Walter Brattain and William Shockley were awarded the Nobel Prize. No one could imagine at that time how fast and widely the transistor would change the whole world.

A transistor can work just like a vacuum tube, but compared with a vacuum tube it is very small in size, light in weight, and a very small amount of electricity is needed to operate it, it is very reliable and most of all, it can be made at a very low cost. Thus it rapidly secured its place, replacing the vacuum tube and the people of the world began to get many electrical appliances by using this transistor at very cheap.

13.2.3 Integrated Circuit

Although the discussion about an integrated circuit was started in 1952, a real integrated circuit was started to be made in the sixth decade. In the fifth decade many transistors were made on a thin silicon plate (Wafer) and eventually the transistors were separated by cutting them from the plate. This process was improved to a small extent while preparing an integrated circuit. Not only

a transistor but also creating a diode, resistor and a capacitor on a wafer, a complete circuit was started to be made. This circuit was named an integrated circuit (IC). With the development of technology many transistors were assembled in a small area, and first it was named Large Scale Integration (LSI), and then it is called Very Large Scale Integration (VLSI). These circuits were made into a ready-made package so that they could be directly used in a circuit board. Modern equipment such as the Micro-computer, clinical appliances, video camera, communication satellite would never be possible without the use of integrated circuits.

13.2.4 Electronics of Future

The technology of electronics is still advancing, and in the future we will experience electronic circuits using optics or light in an information communicative integrated circuit. At the same time we will observe the use of programmable IC (FPGA: Field Programmable Gate Array) in different fields in accordance to our own needs.

13.3 Analog and Digital Electronics

Things that are happening around us every moment, like sound, light, pressure, temperature are expressed as information or data. Their values can be changed continuously. We might need these values in our different works, so we preserve and analyze these values and send them from one place to another. To process the data we might use electronics. This continuously changing data can be converted into electrical signals and these types of signals are called analog signals. If we process these signals with a type of electronics, it is called analog electronics.

Continuously changing information or data signals can be processed in a different way. To do this, we have to find the value for a definite interval of time and express this in a type of number. Then we have to preserve this value successively. Then we will be able to process these numbers using electronics. When it is needed to convert this into the main analog signal again, then electric signals of equal to serially preserved values have to be created. We use decimal

numbers in our daily life. But in electronics numbers are expressed by binary numbers, because they can be easily processed (voltage as 1 and zero voltage as 0). This is called digital electronics (Figure. 13.04) because the values of signals are expressed in numbers or digits.

The greatest contribution of electronics is the computer. The exchange of all data or processing of all data in a computer is processed by digital electronics. Digital electronics is also used in the internet and computer networks to exchange data. Sound, image or video etc. start as analog signals (and is used as analog signal too) but they are stored, processed and sent as digital signal. Noise can spoil the quantity of analog signals very easily by entering the signals. Once it is converted into digital signals, noise cannot enter it very easily. So, the quality of digital signals remains unchanged.

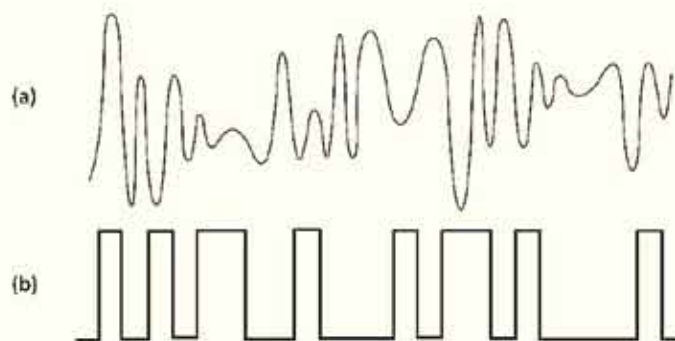

Figure 13.04: (a) Analog and (b) Digital signals

A special type of IC is made to process digital signals. These IC's have become efficient gradually. That is, they can process a large number of signals at a very short time accurately. Therefore, as time goes by, the process of digitizing is becoming easier and it is needless to say that everything around us is being converted into digital world.

13.4 Semiconductor

The modern world and modern civilization have been built on the basis of electronics. If we want to express our gratitude to any substance, that substance will be the semiconductor. We have discussed about the conductor, insulator and semiconductor. Now we can go deeper to a small extent about this subject.

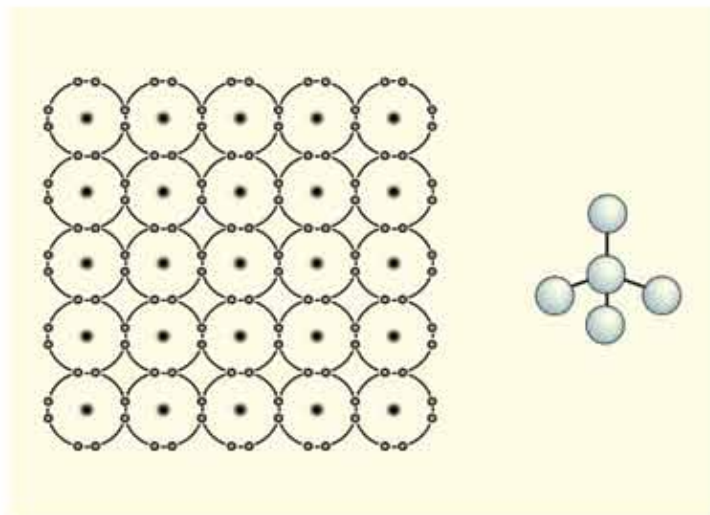

Figure 13.05 : Silicon crystal. Three dimensional silicon crystal (right)

In Figure 13.05 many atoms of a semiconductor have been shown side by side. Due to the structure of the atom if there are eight electrons in their outer most shells, in one sense they are fulfilled and become very stable. Atoms always try to have eight electrons in their outer most shells. Silicon is the most used semiconductor among the semiconductors. The number of electrons is four in its outer most shell. But when we observe a silicon crystal, we find surprisingly that there are eight electrons in the outer most shell of every atom! It has happened because every atom attaches to four different atoms around it, and they are all using their electrons sharing with the neighboring atoms. (We have drawn the figure on a plane. The real arrangement of silicon atoms is three dimensional, as shown at the right side of the Figure 13.05. Actually, every atom touches other four atoms.)

Usually the electrons are bound to the atoms in semiconductors. With the increase of temperature, one or two electrons may become free. There are free electrons in conductors so the semiconductors may act as conductors to some extent. From the view point of physics it is an interesting phenomenon, but not very suitable for practical use. An interesting thing is done to make it more useful. Atoms with five electrons in its outer most shell. e.g, phosphorous are mixed with silicon crystal. Then we suddenly discover that since every atom is in a stable state by sharing electrons with the other atoms and the fifth electron of phosphorus is an extra electron, no atom needs it, so it can move freely among all the atoms of silicon. It is not necessary for the electron to be bound to the atoms of phosphorus. This electron behaves like free electrons by making the phosphorus atom a positive ion. It can be said that such phosphorus adding semiconductors act as conductors to a large extent, because there are some free electrons here to carry charges. The semiconductors made by mixing atoms having five electrons in the outer most shell like phosphorus are called n type semiconductors.

Now get ready to hear something more interesting. Instead of adding pentavalent impurity atoms, if we add atoms having three electrons (e.g. boron) in their outer most shells, to silicon, what will happen? Certainly, it is understood that there is an empty space in the orbit of a boron atom and this empty place can be occupied by a neighboring electron. Then an empty place will be created in the neighboring atom, this place again can be occupied by an electron of its neighboring atom, then an empty place also will be created there. Another way to see it is that an empty place with the lack of an electron is moving from atom to atom. It seems that it is one type of particle and its charge is positive. It is called a hole. That is, we can say that keeping a boron atom as a negative ion, this hole can move through the whole silicon crystal. That is, this semiconductor almost acts as a conductor and positively charged holes conduct electricity through it! When a semiconductor becomes a conductor by adding atoms having three electrons in their outer most shells, it is called a p-type semiconductor.

There were not so many uses of n type and p type semiconductors individually but when n type and p type semiconductors were combined together the greatest discovery of science and technology started.

13.4.1 Diode

In Figure 13.06 it is shown that a p type semiconductor is connected with an n type semiconductor and a battery is connected in such a way that its positive terminal is connected with n type and negative terminal with p type. We have known that n type semiconductors have electrons to conduct electricity, so the positive terminal of the battery cell will pull these electrons quickly towards itself. So there will be no electrons to conduct electricity in the n type semiconductor. This will become an insulator. In the same way electrons will come to the p type semiconductor from the negative terminal of the battery and all the holes will be filled up with electrons, so within a very short time that there will be no holes remaining to conduct electricity. That is, this p type semiconductor will also become an insulator. So if this np semiconductor is connected to the battery, there will be no current flow through it.

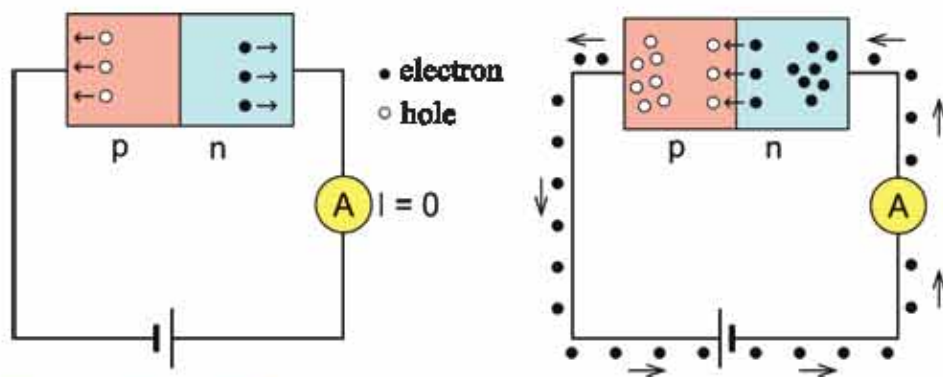

Figure 13.06: A diode made by connecting n type and p type semiconductors. No current flows in one kind of connection of the battery cell and current flows in another connection.

Now what will happen if the np semiconductor is connected in the reverse way to the battery cell? That is, the positive terminal is connected with p type and the negative terminal is connected with n type.

Now electrons enter the n type semiconductor from the negative terminal of the battery and the electrons will be pushed towards the np junction.

Similarly, the positive terminal of the battery will pull the electrons from the p type semiconductor, and new holes will be created. Those holes will rush towards the pn junction. There the electrons will fill up the holes. This will continue and if someone looks at the wires of the battery, then they will see that the electrons travel from the negative terminal to the n type and electrons exit from p type and return to the positive terminal of the battery. This will keep going and we will see that electric current is flowing through the junction amazingly. The semiconductor device produced by p type and n type semiconductors is called a diode. A diode is such an electronic device where current flows in one type of connection of battery but no current flows in the reverse connection.

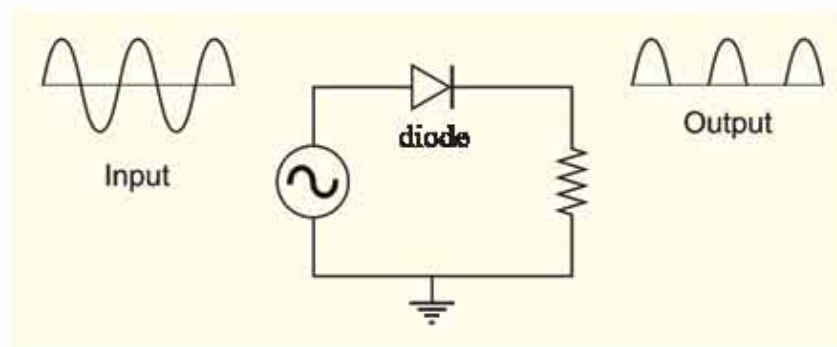

Figure 13.07: The negative part of AC signal can be removed by using a diode.

There is no limit of the usages of diodes which includes general diodes. You often see small lights of red, blue, green and yellow: all those are LED or Light Emitting Diodes. Another interesting use of a diode is to convert AC to DC. The negative part of the AC signal can be removed by using a diode. According to Figure 13.07, if we apply AC voltage within the diode, then on the other side, the negative part will be removed and only the positive part will come out.

13.4.2 Transistor

Those who know about the history of science, if asked about the greatest invention of technology, will probably mention the transistor. A transistor is a kind of device which is made of p type and n type semiconductors, and it can control the flow of current through it. There are two types of transistors, npn and pnp. In the Figure, npn transistor is shown.

This can be compared to a tap of water. When the tap is opened, the flow of water starts, and stops when the tap is closed. Current enters an npn transistor through a collector and exits through an emitter. In the middle there is a base which is similar to a tap. A small amount of current in the base acts like the opening of the tap, and a large amount of current flows. If this small base current is stopped, the flow of current through the collector and emitter also stops (Figure 13.08).

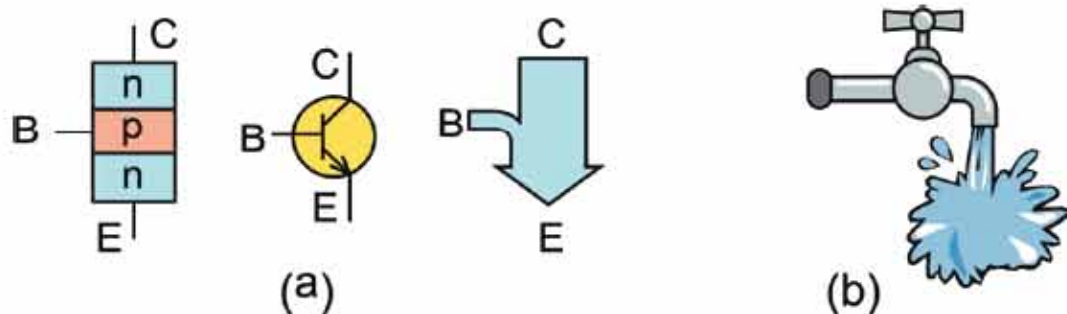

Figure 13.08: (a) Structure, symbol and flow of current of a npn transistor (b) Transistor can be compared with water tap. If a tap is opened a little, plenty of water comes out. Likewise, for a small amount of base current, a large amount of collector-emitter current is obtained.

Many electronic devices are made using transistors. Transistor are used to convert small signals into larger ones, which are called amplifiers. A transistor is also used to process different kinds of signals.

Many important circuits are made using transistor resistor, capacitor, diode etc. With gradual development of technology, a whole circuit has been made by using these various things called an integrated circuit. An integrated circuit is equal to a finger nail in size. First circuits were made by putting thousands of transistors inside it, and gradually it has become possible to put billions of transistors inside an IC. Already you have known that the process of putting a billion transistors inside a chip is called VLSI or Very Large Scale Integration. This process is still improving and more complicated circuits are being made by putting more and more transistors inside a chip.

We are using computers, laptops, calculators, mobile phones and many new electronic devices by means of creating complex circuits with a billion of transistors in a chip. A task of electronics which once needed several rooms or an entire building, is now possible to be done inside a small chip and we carry various devices made by them in our pockets.

13.5 Information and Communications Technology

Information and communications technology is a very well known subject.

We can do many important things easily by using information and communications technology, starting from daily life to professional life. The development of the telephone and telegraph in the nineteenth century created a new dimension in the field of development and communication.

In the twentieth century, radio, television, cell phone or fax have brought about revolutionary change in the field of communication. Recently the computer and internet have the greatest contribution in the field of communication.

13.5.1 Microphone

The electronic device which people use to deliver their speeches in various programs or seminars is called a microphone. A microphone converts the voice of the speakers into electronic signals. This signal is amplified by an amplifier and sent to a speaker. The speaker converts it into sound and an audience can hear it loudly in loud speaker. While you are using mobile phone, you use microphone to speak and listen, even though you cannot see the microphone from outside.

Working Procedure of Microphone

There are various kinds of microphones for regular or special purposes. The construction of an ordinary microphone is shown in the figure. A thin metal plate or a diaphragm is in front of this microphone. A moving coil is connected to the diaphragm which can move inside a magnetic field as shown in Figure 13.09.

When someone speaks in front of this microphone, the diaphragm vibrates along with the sound wave.

The moving coil connected with the diaphragm also moves back and forth in the magnetic field. When a coil moves in the magnetic field, an induction of electricity occurs there. So the microphone converts sound energy into electrical energy and transmits an electrical signal.

Although the electrical signal of sound is an accurate representation of the sound, the signal is very small. So an amplifier is used to amplify it. Afterwards it can be used not only in speakers but also in telephone lines, radio broadcasting or recording.

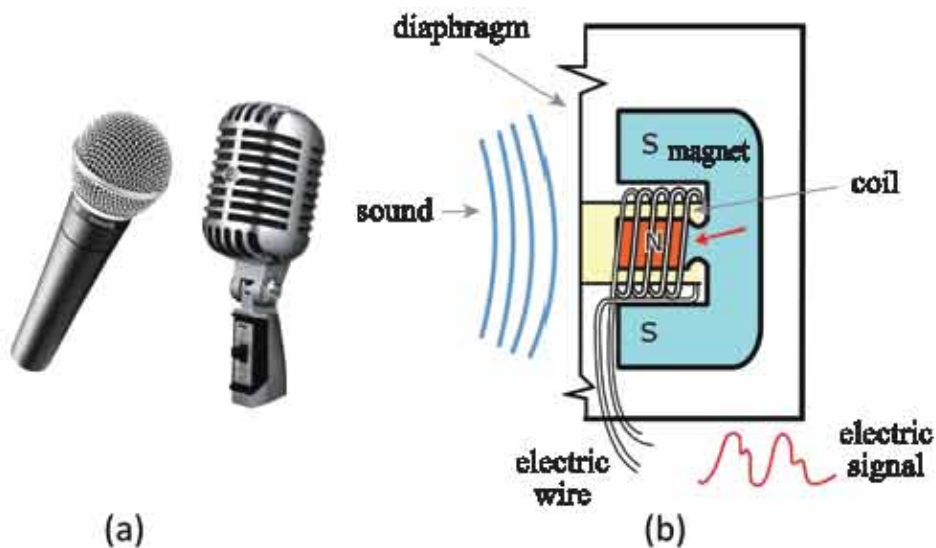

Figure 13.09: (a) Microphone and its (b) construction

13.5.2 Speaker

A speaker does the exact opposite job of a microphone, that is it, converts electrical energy into sound. The construction of a speaker is shown in Figure 13.10. The moving coil in a speaker is connected to a cone made of paper or light

metal instead of the diaphragm in a microphone. When an electrical signal created from sound is amplified by an amplifier and sent to the speaker, the cone of paper or light metal creates sound by vibrating back and forth.

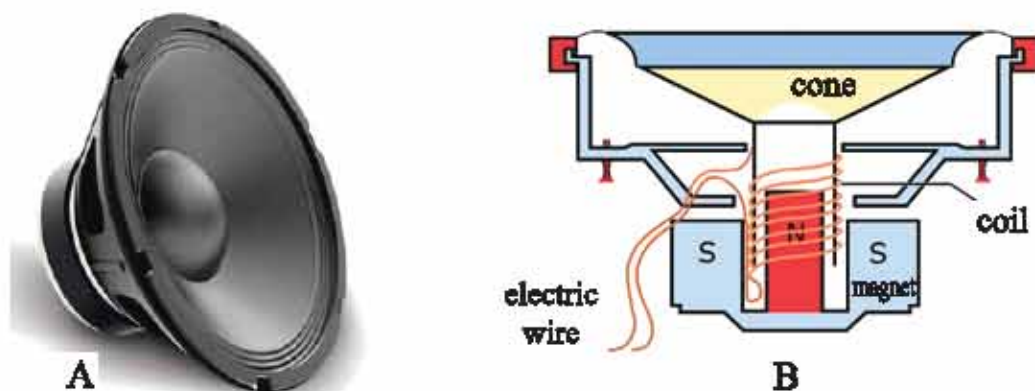

Figure 13.04: (a) Speaker and its (b) Construction

13.5.3 Radio

The Radio is an important medium of communication and entertainment (Figure 13.11). We can enjoy and songs and music, and even advertisement of products. The army and police department use their own radio to exchange information. Radio technology is also used in mobile or cellular telephone communication.



Figure 13.11: Radio Set

When someone speaks on the microphone in the studio of a radio broadcast station, the sound is converted into electrical wave signals. We can hear the sound of frequency from 20 Hz to 20,000 Hz. So, electrical wave signals obtained from the sound signals will be the frequency of this range. These

signals are merged with high frequency waves for transmission. Such high frequency waves are called carrier waves.

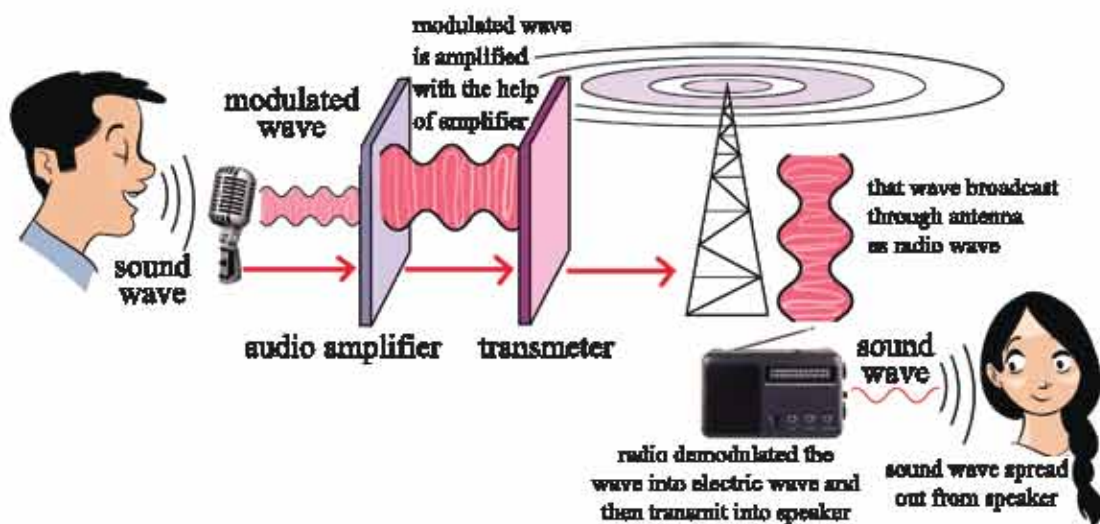

Figure 13.12: The process of radio broadcasting.

The process of merging with carrier waves is called modulation. The modulated wave is amplified by an amplifier, and with the help of an antenna it is transmitted around. These electromagnetic waves or radio waves travel a long distance either as ground waves or reflected waves from the ionosphere of the atmosphere. The antenna at the receiver converts the radio waves into electrical waves. With the help of necessary electrical instruments, the desired waves are separated from the carrier wave. This process is called demodulation. This demodulated electrical signal is amplified by an amplifier and sent to the speakers for listening (Figure 13.12).

Radio Broadcasting Stations use individual frequency to transmit their radio waves. The receiver device needs to be tuned at a certain frequency to listen to a specific station. So the different radio stations can broadcast their own programs and the listeners can tune to the program of a specific station according to their choice.

The process of increasing or decreasing the amplitude of the receiver wave merged with a carrier wave, is called AM (Amplitude Modulation). If the amplitude is kept unchanged, and the frequency the modulation is changed, this process is called FM (Frequency Modulation) radio.

13.5.4 Television

All of you have seen a television. It is a device where we can see videos or moving pictures along with sounds, which are broadcasted from a far distant television broadcast station (Figure 13.13). In 1926 John Logie Baird was the first person who sent videos or moving pictures through a television. His process was a mechanical process. Later on, the process of sending pictures by using electronics became more developed .



Figure 13.13: Old and present television set

If you understood how the radio transmitter and receiver works, then you will easily understand how a television works.

In television, the sound and pictures are sent as separate signals. We have already discussed the process of transmitting sound and receiving it at the receiver. Here, we will discuss the picture transmission process.

To send moving pictures or videos, 25 still pictures are sent per second. In our eyes, these pictures are not seemed to be separate pictures; rather they look like motion pictures. To send colored images, the television camera captures three different images of every picture by dividing it into three fundamental colors namely red, green, blue (RGB). Light is converted into electrical signals by using CCD (Charge Coupled Device) in television cameras. This electrical signal is sent using high frequency carrier waves through an antenna (Figure 13.14).

The receiving device or the television set receives the high frequency carrier wave with the help of the antenna, separates the carrier wave, and obtains the main picture signal from by a rectifier. Previously, three images of the three colors from this signal was projected on the screen of picture tubes known as cathode ray tubes through an electron gun.

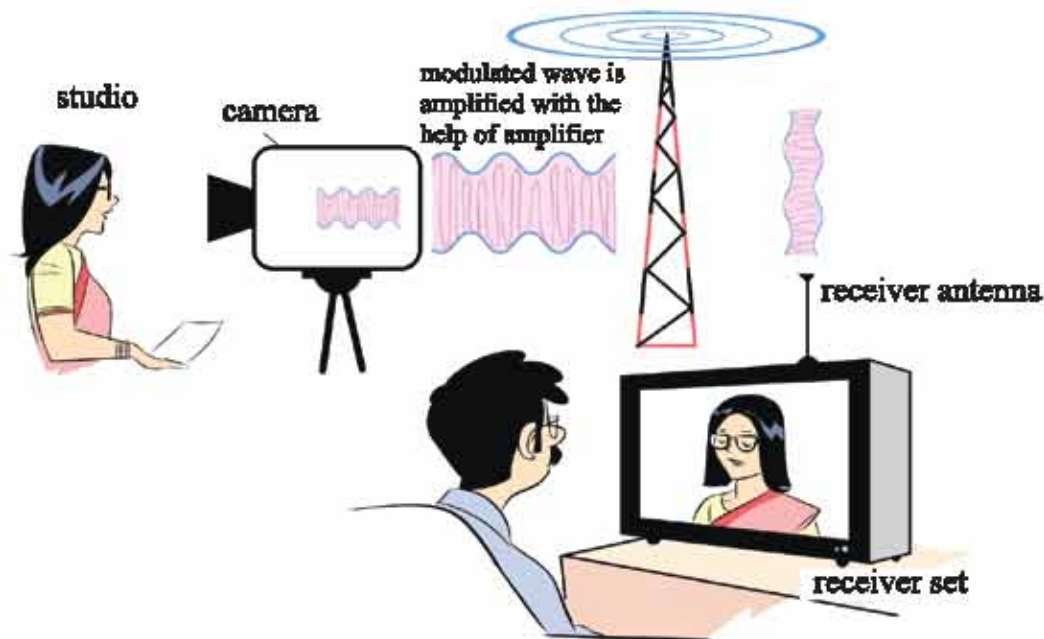

Figure 13.14: Television broadcasting process.

But now-a-days, picture tubes are hardly used, and LED televisions (Light emitting diode) are used instead. Electron guns are no longer used to create pictures on the screen. Instead, pictures are produced by passing current through small LEDs of red, green and blue colors. The brightness of pictures in LED television is more vivid, and its qualitative value is also better.

The signals of television can also be sent through coaxial cables as well as antenna. This type of TV broadcasting is called cable TV. Besides this, one type of TV program called satellite TV is broadcast. These programs are transmitted to the earth directly from the satellites placed in space.

13.5.5 Telephone and Fax

The telephone is the greatest and the most used medium of communication in the world. With the help of this telephone, (Figure 13.15) we can now contact any person in any corner of the world.

Land Phone

The telephone was invented by Alexander Graham Bell in 1875. It has taken the form of modern telephone in many ways, but its main functioning process still remains the same .



Figure 13.15: Land phone and mobile phone.

All of you have seen and used a telephone. A telephone has five components: These are,

- (a) **Switch:** which connects or disconnects with the main telephone network.
- (b) **Ringer:** which alerts a telephone subscriber to an incoming telephone call by making sound.
- (c) **Key pad:** through which one can dial.
- (d) **Microphone:** which converts our voice into electrical signals.
- (e) **Speaker:** which enables us to listen by converting electrical signals into sound signals.

Every telephone is connected to regional offices by a copper wire. When we dial a number to talk to someone, at first this information passes to the regional office. There is a switch board in the office which connects the dialer to the telephone number of the receiver. If we wish to contact someone in distant places or abroad, the switch board connects us with a certain network in the same process. Before the progress of technology, using a telephone, a conversation between two persons of two corners of the world was very expensive, because the telephones had to be connected by copper wire to send voices. In modern communication system the whole thing becomes much easier, now it's actually possible to transfer millions of people's conversation through an optical fiber at the same time. So, telephone conversations have become very easy.

Mobile Telephone

As land phones are connected by copper wires, it has to be kept in a definite place and to use it we have to be physically present near it. The mobile phone has freed us from this obligation and we can carry it with us. As long as we remain within the network, we can call, talk to or exchange SMS with anyone. That's why mobile phone is now the most used and the most popular medium of communication.

You have seen that a mobile phone is not connected by any wire, which means it communicates through wireless or radio waves. Therefore, every mobile phone actually acts as a radio transmitter and a radio receiver at the same time.

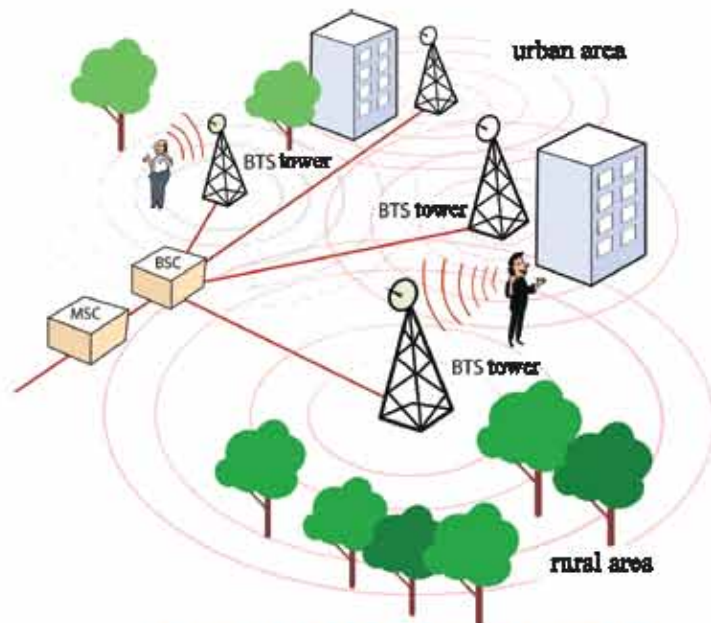

Figure 13.16: Mobile telephone network.

The mechanical components that are needed for a land phone are also necessary for a mobile telephone phone. Along with this, mobile phone has some extra parts too. These are:

- (a) **Battery:** Electric energy is supplied to the mobile phone by the battery.
- (b) **Screen:** Information for communication is displayed on the screen.
- (c) **SIM card (SIM: Subscriber Identity Module):** Stores the information of the user.
- (d) **Radio transmitter and receiver:** Mobile phone connects with its network using these instruments.
- (e) **Electronic circuit:** Helps to carry out the complicated functions of the mobile phone properly.

The whole area is divided into many cells in order to perform the communication functions via mobile phones (Figure 13.16). Hence, mobile phones are often called cell phones. These cells can have 1 to 20 kilometers range according to their need. Every cell has a base station (BTS: Base Transceiver Station).

Many base stations of an area connect with one Mobile Switching Centre (MSC) with the help of a Base Station Controller (BSC). The mobile switching centre is the most important part of a network. Here the sender is connected with the receiver. When anyone (sender) dials another number (receiver), the sender's mobile phone is connected with the base station (BTS) of his cell.

Then the call is forwarded through the base station controller (BSC) to the mobile switching centre (MSC). The mobile switching centre then finds out (from its stored information) the cell of the receiver's mobile phone at this moment. Then it connects the sender's call to the receiver's cell's base station, and then a ring is given to the receiver's mobile phone from the base station of the receiver.

To make the mobile network active many technological innovations have been made. Using very low energy signal from our mobile telephone, connection is made to a nearby base station. If we move from one cell to another, this network can identify it, and transfers the connection from one base station to another base station. If there are many mobile phone users in a densely populated city, then they are given the opportunity to make calls by creating many small cells. Whereas in a village, that has a very small population, the whole area is connected to the network using a huge cell.

It is noteworthy that first, the telephone was invented only for conversations among the people. Exchanging SMS is a new feature that was added to the mobile phone. The new phones (called smart phones) that are available now-a-days can transfer all kinds of data in addition to voice. That's why they can be directly connected to the internet. Activities that were thought to be impossible without a computer or laptop before are now easily done with the help of smart phones. That's not all; the addition of many apps (application) for smart phones has enabled us to do various types of functions too.

Smart phones have brought a revolutionary change to our lifestyle. At the same time, the new generation is wasting time unnecessarily on due to the opportunity to access the internet easily through smart phones things like social network. At this time this is a great problem not only in our country but all over the globe.

Fax

The word “fax” is the short form of the word “facsimile”. By sending fax we mean the direct transmission of a copy of any document using telephone line instantly. Fax technology is far behind the computer, network, and internet of the present age but almost all organizations are still using this old but reliable technology. You will be astonished that though fax is sent through telephone line, the concept of fax was first patented thirty years before the invention of telephone.



Figure 13.17: Fax machine and its functioning.

A fax machine can send a copy of a document and can print a document that is sent to this machine (Figure 13.17) at the same time. When a document is kept in the fax machine, a bright light is focused on it. The white area of the document reflects more light whereas black area reflects a little. Storing this information, the copy of the document is transformed into electrical signals and sent through the line of telephone.

The fax machine at the receiving end of the telephone line prints the copy of the document sent to it using a printer. The fax machine is still a reliable technology; it sends a copy of any document only as black and white; though it is suitable for written documents it is not appropriate for photographs or colorful ones. Besides this, thermal papers are used in most of the fax machines, so the document may fade very quickly.

13.6 Internet and E-mail

13.6.1 Internet:

You have read many times what a computer is and how it works. Generally the computers of an organization are interconnected using a network, so that one computer can access other computers and can use the resources of another computer if necessary. Such type of network is called LAN (Local Area Network). Now-a-days in order to make a LAN, many computers are connected to a switch and the switches are then mutually connected. When a computer has to communicate with another, at first, it searches for the desired computer connected to its own switch and if it finds it, it connects with that computer directly. Otherwise, it searches in other switches.

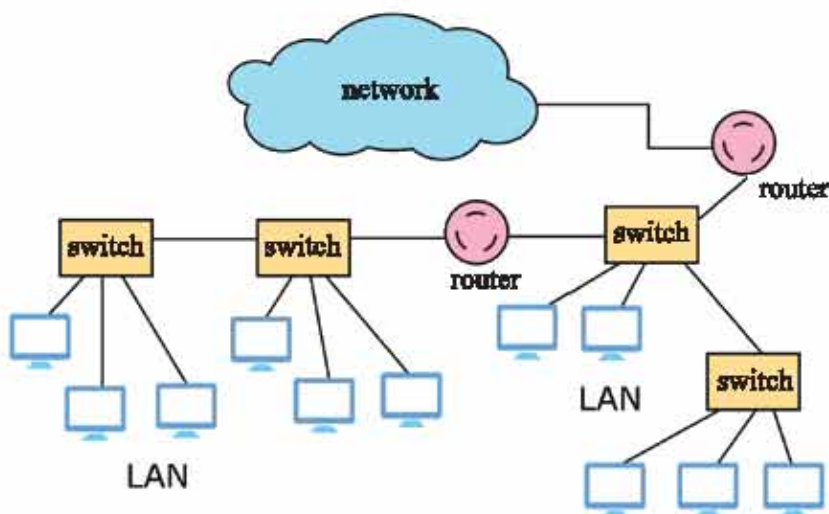

Figure 13.18: Several LAN connected to a network.

A router is used to join a LAN of an organization to the LAN of another organization (Figure 13.18). The internet is a network of the inter connection of different networks. At present, almost nine billion computers or other devices of the world are connected with the internet and the number is increasing every day. Therefore, the internet is the network of all networks where all types of networks such as private, public, educational institutions, business, government, non-government, local or global are included. In order to develop this giant network, various kinds of electronics, wireless and fiber optic network

technologies are used.

By using the internet, various types of information can be exchanged and different types of services can be provided. For instance, it can be said that there are different types of websites, electronic mail, telephone and video communication, exchange of information, social network, recreation, education and research tools and different types of internet based services in the internet. Now, people all over the world are dependent on internet and a revolutionary change has occurred in our lifestyle.

People around the world have equal opportunity to communicate on the internet, as a result there is a scope of use and abuse of internet in different types of publicity. Moreover damaging the network by making different types of harmful software, spreading adversity and envy, presenting objectionable information, etc. are some example of internet abuses. Criminals also use internet secretly in their activities!

In spite of having some demerits, the internet is the greatest contribution of this civilization and this is the first time, people around the globe have an equal opportunities to participate in technology. People all over the world are eagerly waiting to see the effect of this network in the world of future.

13.6.2 E-mail

E-mail is the short form of electronic mail. By e-mail we mean the exchange of digital information with one or many persons using the network, with the help of digital devices such as computers, tablets, smart phones etc. E-mail was first sent in 1971 and within only 25 years, the number of e-mails was greater than the number of letters sent by using post office. Now we cannot imagine a day without using e-mail.

The e-mail address of both the receiver and the sender are needed in order to send an e-mail. All of you are familiar with an email address and you have noticed that the email address is divided by the letter @. If an email address is abc@def.com, the part after @ is domain name, which means the organization in which the user is involved. The first part is some type of identity of the user.

An e-mail server is always needed to send an e-mail using computers, laptops, tablets or any other digital devices. This e-mail server preserves the e-mails of the users and exchanges e-mail with other users through the network. Another

way of exchanging e-mails (and at present a very popular way) is the email service provided by the internet. The e-mail services of Gmail, Yahoo, Hotmail etc. are not only free of cost, they take the responsibility of storing e-mails of the users also.

The email addresses of the sender and the receiver always have to be written to send an e-mail. An e-mail can be sent to more than one person as a “Carbon Copy (CC)”, if necessary. At the beginning of the e-mail, a headline of the text of the e-mail can be written as the subject. Along with writing the content, any document, pictures etc. can also be sent by attaching with the mail.

E-mail, internet or different types of internet based social networks have opened the door to many new possibilities. At the same time, the misuse of these technologies can bring great disasters in our life.

So, we have to use these very powerful technologies with responsibility. This is applicable not only for information technology but also for all other technologies.

13.7 Effective Use of ICT

13.7.1 Health Problem

Different kinds of health problems may occur due to the uncontrolled usage of information and technology. Those who work on computers for a very long time feel excess stress or pressure in their veins, nerves, wrists, arms, shoulders and neck due to prolonged use of keyboards or mouses. That is why, different types of problems may be created if enough rest is not taken in between work.

Different types of eye problems are also caused when working for a long time without rest, which is called computer vision syndrome. This syndrome includes eyes irritation, dryness of eyes, eyes itching, becoming eyes red and the drying of tear.

It is wiser to prevent these types of health problems than to treat the problems caused by the use of computers. We have to be cautious so that these health problems are not created. If we abide by some easy rules, we can prevent these problems. e.g.

- (a) We have to sit properly and look straight while working on computers.
- (b) We have to take rest at least for 5 minutes after every half an hour and relax the neck and shoulders.
- (c) The screen of the computer should be 50 - 60 cm away from eyes.
- (d) We have to look at something far away for a while,(after every 10 minutes) so that eyes feel comfortable.

13.7.2 Mental Problem

Mental problems caused by excessive use of computers can be more severe than physical problems. Now-a-days, everyone can use the internet due to its availability. The realm of information and knowledge is opened in internet; on the other hand, it can also cause problems for users through social network services. Psychologists have started to show through research that people may become addicted to excess use of computers, the internet, or social networks (similar to the addiction to narcotics). There are even examples of death due to excessive playing of computer games. Therefore, we always have to remember that modern technology is not always good. As there are many unnecessary and harmful technologies in the world, likewise, the misuse of good technologies can also become a curse in our lives.



Do Yourself

Write a report on how e-mail, internet and social networks can be used as responsible one.



Exercise



General questions

1. If a neutron can turn into a proton emitting a beta particle, then why are not all neutrons inside a nucleus gradually converted into protons?
2. The resistance of a resistor increases with an increase in temperature, but why does the resistance of a semiconductor decrease with an increase in temperature?
3. What is radioactivity? Explain.
4. Explain the difference between alpha and beta particles.
5. What is an integrated circuit?
6. What is the internet? What can you do through it?
7. How does fax work? Explain.



Mathematical questions

1. The amount of C_{14} in a fossil is 16 times less than expected. How old is the fossil?



Multiple choice questions

Put the tick mark (✓) on correct answer

1. What do you mean by an alpha particle emitting from a radioactive element?
 - (a) a hydrogen nucleus
 - (b) a helium nucleus
 - (c) a neutrally charged particle
 - (d) a negative particle

2. What is a beta ray emitted due to the radioactive decay?
 - (a) the flow of negative electrons
 - (b) a charge neutral particle
 - (c) a positive nucleus
 - (d) flow of positive protons

3. What is a silicon chip called if millions of circuits are added to it?
 - (a) parallel circuit
 - (b) semiconductor transistor
 - (c) integrated circuit
 - (d) semiconductor diode

4. What is the function of a camera in broadcasting television?
 - (a) to transform picture into electrical signal
 - (b) to transform picture into sound wave
 - (c) to transform electrical signal into picture
 - (d) to transform sound wave into picture



Creative questions

1. The world is getting smaller. We live in a global village. Information and communication technology have connected all the people of the world effectively and efficiently. The major media of communication are television, radio and telephone.
 - (a) What is a communication machine?
 - (b) How does a telephone work? Explain.
 - (c) How does a radio station transmit a signal of definite frequency and how does it reach the people? Explain with a diagram.
 - (d) Analyse and compare the effectiveness of television and radio as communication device.

2. The cricket match between Bangladesh and India is being telecast on BTV from the Premadisha stadium, Srilanka. As a result, we can enjoy the cricket match on television sitting at home.

- (a) What is an analogue signal?
- (b) Explain a digital signal with a picture.
- (c) Explain the telecast-technique of the cricket match.
- (d) How does the communication technology improve the standard of life? Explain.

3. Shovon finds a broken radio in his house. He separates the different parts of the radio. Among them he finds a machine which is wound up with wire and a magnet which is attached to a screen. Asking his father, he came to know this part of the radio produces sound. He starts to think about how these parts make sound.

- (a) What is IC?
- (b) Why are analog and digital signals different?
- (c) Draw a flow chart of the process of how the machine found by Shovon makes sound.
- (d) If the machine which is found by Shovon is not used now, then analyse the main problem that could happen.

Chapter Fourteen

Physics to Save Life

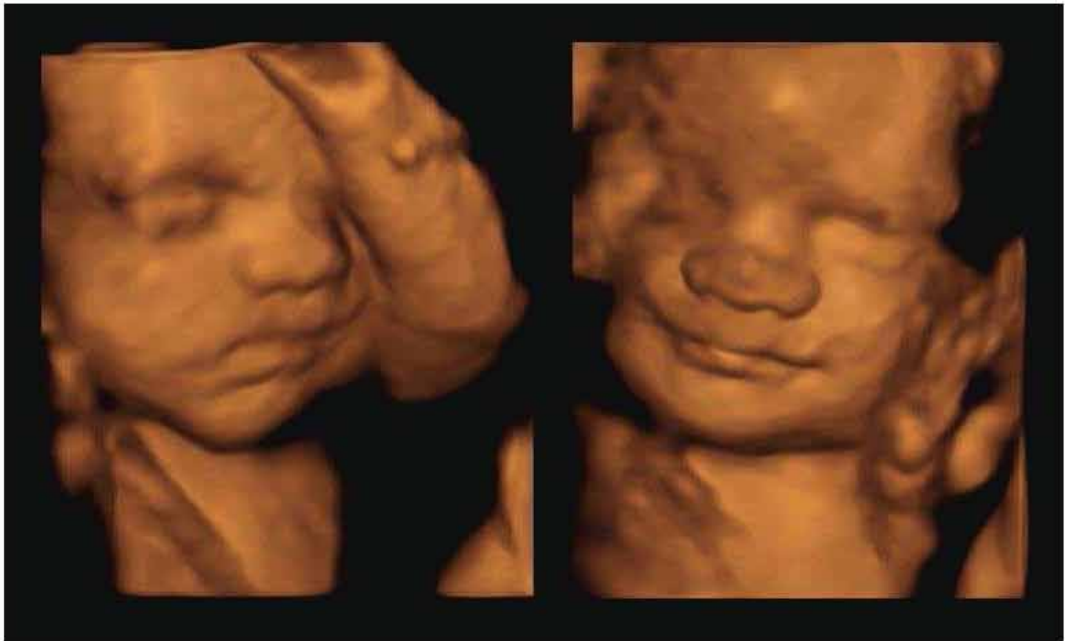

Physics, combined with other subjects, has given birth to different new disciplines of science. Biophysics is one of them. We have already started to enjoy the benefits directly provided by this new field of science in medical science. Could we ever imagine that we would be able to see all our internal organs without dissecting the human body? But now we are being able to do that impossible task by using the newest inventions of physics. In this Chapter, many instruments that are used in medical science have been discussed. Diagnosing diseases is no longer based on assumptions only. In most cases it is absolutely specific. Physics is not only used for diagnosing diseases, but also for the treatment and remedy of diseases. Many such examples are discussed in this chapter.



By the end of this chapter we will be able to-

- explain the basis of biophysics.
- explain the contributions of Jagdish Chandra Bose in biophysics.
- explain that the human body functions following the rules of physics.
- explain the application of ideas and theories of physics in the instruments for diagnosis of diseases in medical science.
- explain the hazards of using modern technology and devices, and mechanisms of prevention.
- become conscious about the necessity of diagnosis of diseases for proper treatment, and raise consciousness among others.
- appreciate the contributions of science and technology for the diagnosis of diseases.

14.1 Background of Biophysics

Biology tries to understand the diversity of the living world and the process through which living things lead their lives. How do the animals collect food, develop relations among one another, perceive the environment and reproduce – all these are the subject matter of biology.

On the other hand, the laws followed by the physical world of nature and the simple mathematical explanations of those laws are the subject matter of physics. It may seem that there is no link between the simplicity of physics and the complexity of biology.

But with the advancement of science, and depending on its different branches, a relation has been established between biology and physics. This new field has been named biophysics. Biophysics employs the simple and mathematical laws of physics in the complex processes of biology and thus investigates various mysteries of life. Biophysics is the bridge between biology and physics.

Bio-physics in one way can identify the arrangement of atoms and molecules in DNA or protein; similarly it can invent cancer treatments or artificial kidneys using technology. There is no doubt that biophysics can also play significant roles in controlling environmental pollution and thus save the biodiversity of the future world.

14.2 Contributions of Jagadish Chandra Bose

Acharya Sir Jagadish Chandra Bose (Fig: 14.01) was a renowned physicist, as well as a successful biologist. He was the first internationally recognized scientist of this subcontinent. The forefathers of Jagadishchandra Bose lived at the village of Rarikhal of Bikrampur in Dhaka district. He was born in 1858 in Mymensingh. His father, Bhagaban Chandra Bose, was a deputy magistrate of Faridpur district.

His education started in a rural school of Faridpur. Later he completed his studies from Hare School and Saint Xavier school and college in Kolkata. After passing his B.A. in 1880, he went to England, and from 1880-1884 he completed his honors with BA in Physics from Cambridge University, and then acquired B.Sc.

degree from London University. Returning to his motherland in 1885, he became a professor of physics in Presidency College. In that time there was not enough scopes for research in that college, but he continued his research anyway. He was always busy during the day. So, he carried on his research at night.

He conducted a lot of research on how to send radio signals without electric wires. In 1895, for the first time he sent a wireless radio signal to distant places and demonstrated this publicly. He has great contributions in microwave research; he was the first to reduce the wavelength of the electromagnetic wave to the order of millimeter (nearly 5 mm). Acharya Jagadish Chandra Bose used semiconductor junctions to detect radio signals. Instead of patenting this invention and obtaining commercial benefits from it, he opened it for all.

In later years, Jagadish Chandra Bose discovered many important aspects of plant

physiology. Among those, the invention of the Cresco graph to record the growth of plants, detecting very minor movements, and matters of responding to various stimuli are worth mentioning. Earlier it was assumed that response to stimuli was a chemical process. He showed that it was actually electrical in nature.

In 1917 he established the Bose Biggan Mandir in Kolkata for research on plant physiology. The writings of Jagadish Chandra Bose in bengali were compiled in a book named 'Obyakto'. A significant book of his is 'Response in the living and nonliving'. On 23 November 1937, scholar Jagadish Chandra Bose breathed his last.



Figure 14. 01 Acharya Sir Jagadish Chandra Bose

14.3 Human Bodies and Machines

In our daily life we use many different types of devices. To travel we use cars, to preserve food we keep them in the refrigerator, for comfort on hot days we turn on the electric fan, to learn news we watch the television etc. This list is very long and for that reason we can understand what a machine or device means. We know that the human body cannot be called a machine. A complete human being is created from just a single cell. There is no machine in this world that starts from a small unit and then transforms into a complete machine on its own. If any malfunction arises within the body, an automatic repair mechanism gets initiated, but no machine can do such a thing. But, still, to compare with the known world or to describe the functions of the different organs of the body, we often compare the human body with machines.

For example, it can be said that our heart is an automatic pump that circulates blood spontaneously without any external stimulation. Our kidney is a filter that removes nitrogenous waste from the blood and thus purifies it. The bones and muscles of the body work as mechanical levers and our eyes in many ways acts like a camera. Not only this, but the human body is made up of small parts or organs just like a complex machine, and each organ performs a definite task. If any organ suffers a malfunction then the whole body's work faces obstruction. So, it can be said that the human body is like an organic machine.

We need energy to do work with the help of machines. In different engines petrol, diesel, gas etc. are used as fuel to transform chemical energy into mechanical energy. Similarly, eating food and through respiration we obtain energy for our body from the nutrition of food.

In this way, we can find many similarities between the human body and machines, but we have to remember that the human body is far more amazing, far more surprising and far more mysterious than the most complex machine of the world. We have not been able to solve completely even a small fraction of that mystery.

14.4 Diagnostic Instruments

In 1950, the average life expectancy of humans was nearly 50 years, but within sixty years, the lifespan has increased by 20 years. The development of lifestyle of the people of the world, the use of disease remedies, the increase of health consciousness and the development of treatment around the world are the

reasons behind the increase of life expectancy.

You can certainly assume that there is a relationship between the increase of the lifespan and the development of medical science. And behind the development of medical science lie modern machines that have enabled us to correctly diagnose the diseases. There was a time when doctors used to identify diseases just by analyzing different symptoms. Back then many things of the body had to be assumed. Diseases could not be identified properly. Due to the advent of modern machines, not only can different diseases can be identified accurately but also treatment can be done effectively.

In this chapter, some machines that are used to diagnose diseases and for treatment purposes are discussed. You will see that in each of these instruments, one or another invention of physics has been applied directly.

14.4.1 X-Ray

In 1885, Wilhelm Roentgen discovered a type of high energy ray that can penetrate through muscles of the body and can create an image on a photographic plate. The nature of this ray was not known then and hence the ray was named X-ray. Now we know that X-ray is an electromagnetic waves (like light) but its wavelength is many thousands times smaller than that of visible light, and thus its energy is many thousand times more than that of ordinary light. As the wavelength is very small, we cannot see X-ray with our naked eyes.

How X-ray is produced is shown in Figure 14.02. On the two sides of a glass sphere are two electrodes- a cathode and an anode. The cathode tungsten is heated by passing electricity through it. Due to heat, electrons are released from the filament and because of the positive voltage of the anode, the electrons rush towards the anode. The more the voltage is between the cathode and anode, the more the kinetic energy of the electrons moving towards the anode.

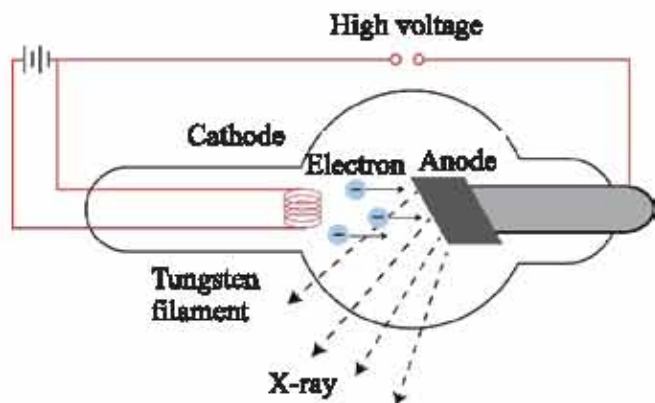

Figure 14.2: Working mechanism of X-ray tube

In the X-ray tube the voltage is nearly 100 thousand volts. The high energy electrons coming from the cathode hit the anode.

Due to these energetic electrons the electrons of the inner shells of the atoms of the anode comes out of the orbit. Then, an electron from the outer shell occupies this empty space. Thus the residual energy of the electron is released as an energetic X-ray. The wavelength of the emitted X-ray depends on the metal used in the anode.



Figure 14.03: X-ray of palm and feet

Generally, copper is used as

an anode. In Figure 14.03, X-ray images of the palm and feet are shown. X-ray can be used in many ways; some of the uses of them are listed below.

1. Dislocated bones, crack in bones, fractured bones can easily be identified using X-ray.
2. To diagnose cavities of teeth and other decay, X-ray is used.
3. By doing X-ray of the abdomen, intestinal obstruction can be detected.
4. Existence of gall bladder stone and kidney stone can be detected by X-ray.
5. Taking X-ray image of the chest, tuberculosis, pneumonia, lung cancer can be detected.
6. X-ray can kill cancer cells, so it is used in radiotherapy for treatment.

Necessary precautions should be adopted so that unnecessary radiation of X-ray cannot cause any harm to the body. For this reason, the patient's body is covered with lead apron except the parts that will be imaged by the X-ray. Other than for absolutely urgent reasons, the lower abdomen of pregnant ladies should not be exposed to X-rays.

14.4.2 Ultrasonography

Images of the internal organs, and muscles of the body are captured using ultrasonography. To do this, a very high frequency sound is produced and its echo is used. As the frequency of the sound lies between 1-10 mega Hertz, this is called ultrasonography. In Figure 14.04, general 2D and recently invented 3D, ultrasonography images are shown.

In an ultrasonography machine, a crystal called a transducer is stimulated with electrical energy to produce a high frequency ultrasonic wave. In the ultrasonic machine, this wave is transformed into a narrow beam. The transducer is touched upon that part of the body, needs to be imaged. The beam enters the body, and thus the patient does not feel any pain or discomfort. The beam is reflected, absorbed or transmitted depending on the organ towards which the beam is directed.

When the beam incident on a muscle or on an interface of the blood of different densities,

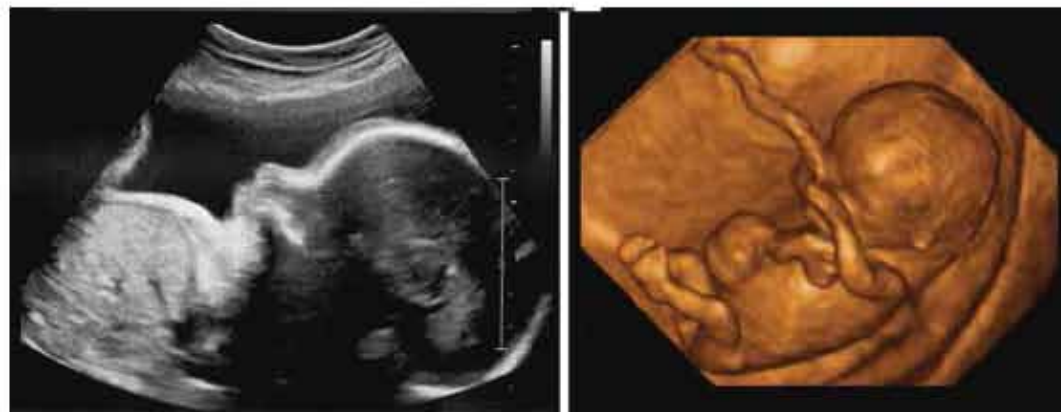

Figure 14.04: Normal 2D and 3D ultrasonography image

part of the beam is reflected back to the transducer as an echo. The reflected echoes are then transformed into an electrical signal, and combined, and then a complete image is formed.

Ultrasonography is used to do the following :

a) The most important use of ultrasonography is in gynecology and obstetrics. With the help of this, the size and position of fetus can be known. In obstetrics it is a fast, safe and dependable technique.

b) Uterine tumor and presence of other pelvic masses can also be detected using ultrasonography.

c) Bile stones, defects in the heart and tumors can be detected with ultrasonography. When ultrasound is used for examination of the heart, then this test is called echocardiograph.

Ultrasonography is much safer than X-ray, but still instead of using excessively, it is used for a very limited time. During the process of ultrasound the transducer is continuously moved so that it cannot send the beam to a specific region for a long period.

14.4.3 CT Scan

CT scan is the abbreviation of the word Computed Tomography Scan. Tomography means to create an image of a slice (or two-dimensional part) of a three-dimensional object. In medical science, X-ray is used in this machine. In an ordinary X-ray, a two-dimensional image of a three-dimensional internal organ is taken once. In a CT scan machine, an X-ray tube rotates around the patient's body in a circular way emitting X-rays. From the other side, a detector records the image. To make the image clear, often a special contrast material is injected into the patient's body.

After getting the X-ray image of the surroundings, they are analyzed by a computer and then coordinated, and thus the internal structure of a complete slice is obtained. After recording the image of a slice, the CT scan machine moves the patient a bit forward and again records another X-ray image circularly; analyzing them creates a complete image of the internal structure of a second slice (Figure 14.05). In this way, moving the patient forward gradually, the image of many slices of an organ of his body is recorded. As we get a complete loaf of bread by arranging the many slices one after another, we can form a three dimensional image of the internal organ of the body by accumulating the images of many slices of that organ. You can tell that the CT scan machine is a costly, complex and large machine by

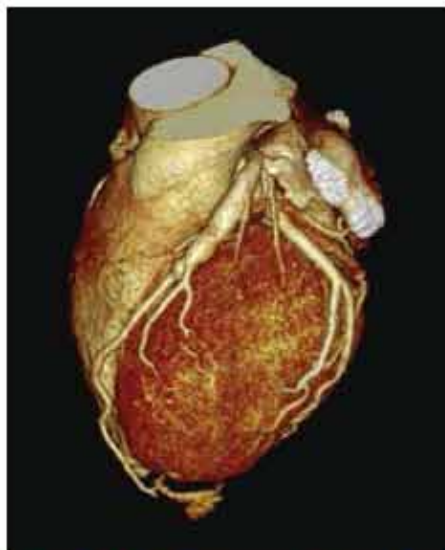

Figure 14.05: CT scan of the heart

knowing about its working procedure. But as this machine can build a flawless, three-dimensional image of any internal organ without going inside the body, it is an essential machine for modern medical science (Figure 14.06).

The following can be done using CT scan:

a) Complete image of the soft tissues, blood carrying arteries and veins, lungs, brain etc. can be found by CT scan.

b) To diagnose cancer of liver, lungs and pancreas, CT scan is used.

c) CT scan image can detect a tumor. It can also tell about the size and position of the tumor and tell how much the tumor has affected the adjacent tissues.

d) CT scan of head can detect whether there is any hemorrhage in the brain, dilation of veins or if there is a tumor.

e) CT scan can also detect whether there is any problem in blood circulation of the body.



Figure 14.06 : CT scan machine

Caution: As X-ray is used in CT scan, CT scan test is not done for pregnant women. The dye that is used to increase the contrast of image may cause allergic reactions in some people, so it must be used with caution.

14.4.4 MRI: Magnetic Resonance Imaging

Almost 70% of the human body is water, which means water is present in almost all organs of the body (each molecule of water contains hydrogen and the nucleus of hydrogen is the proton). When a strong magnetic field is applied, the protons are aligned in the direction of the magnetic field. Then if an electromagnetic wave of definite frequency is sent, then these protons receive energy from that wave and change their direction. This process is called Nuclear Magnetic Resonance (NMR). Based on this remarkable event of physics, Magnetic Resonance Imaging (or in brief, MRI) has been made (Figure 14.07).

The MRI machine looks like the CT scan machine but its working process is completely different. In a CT scan machine, X-ray is sent to record images, but

in an MRI machine, the patient is kept in a very strong magnetic field and a radio frequency electromagnetic wave is applied to his body. Analyzing the signals returning from the hydrogen protons inside the water molecules present in the body with a computer, the MRI machine make images of the internal organs.

The things that can be done using CT scan, are also possible using MRI. But, the differences within the soft tissues in the body can be understood better with the help of a MRI. A CT scan procedure does not require more than five to ten minutes. Compared to that MRI takes more time. X-ray is used in CT scan, so however small the radioactivity is, a risk remains. In MRI there are no such risks.

MRI cannot be done if there is any metallic instrument (e.g. Pacemaker) inside the body, because the radio frequency (RF) wave can create dangerous situations by heating up the metal.



Figure 14.07: MRI machine

14.4.5 Angiography

Angiography is used to see the blood vessels of the body using X-ray. As blood vessels cannot be seen properly by doing normal X-ray a special contrast material (called dye) is entered into the vessels at the time of angiography. A narrow and flexible tube is entered into the body through an artery to inject dye at the part of the vessel that needs to be examined. This narrow and flexible tube is called a catheter. After injecting dye to the specific part of the blood vessel by the catheter, an X-ray image of that part is taken. Due to the presence of the dye, the blood vessels can be seen clearly in an X-ray. The dye is later filtered by the kidney and passes out of the body with urine.

Doctors suggest an angiogram to detect the following problems:

- Blockage of arteries outside the heart (Figure 14.08). If the arteries get blocked, then blood cannot flow normally, and the heart cannot function properly if adequate blood supply is not maintained in the heart. Thus, the risk of heart attack increases.
- If arteries get dilated.
- To detect the condition of the renal arteries of kidney.
- If there is any problem in the veins.

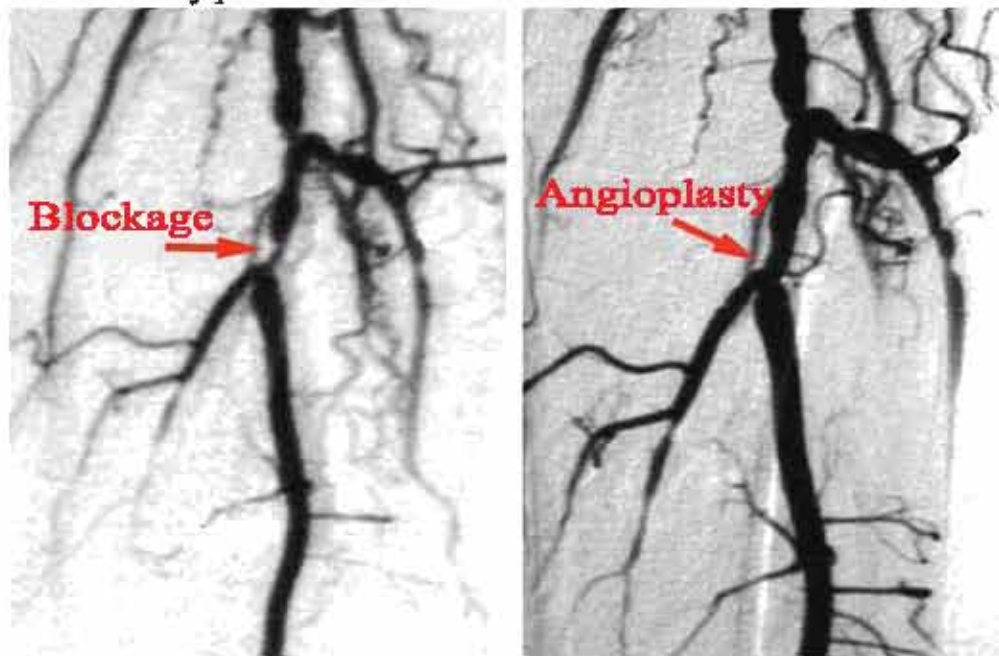

Figure 14.08: In the left, angiography shows the blockage in the blood vessel and in the right picture normal blood circulation is shown after angioplasty.

During CT scan and MRI, everything is done from the outside of the body. As a catheter is inserted into the arteries during angiography, treatment of blocked arteries can be done without any surgery. The process by which the blocked arteries are opened during an angiogram is called angioplasty.

A balloon is sent through the catheter during angioplasty, which is blown up in size to open the narrowed artery. Sometimes a ring is inserted at the spot so that the artery remains wide and adequate blood flow is ensured.

14.4.6 Endoscopy

The process of seeing any internal organ or cavity directly from outside is called endoscopy. An endoscopy machine can be used to investigate the interior of hollow organs within the body (Figure 14.09).

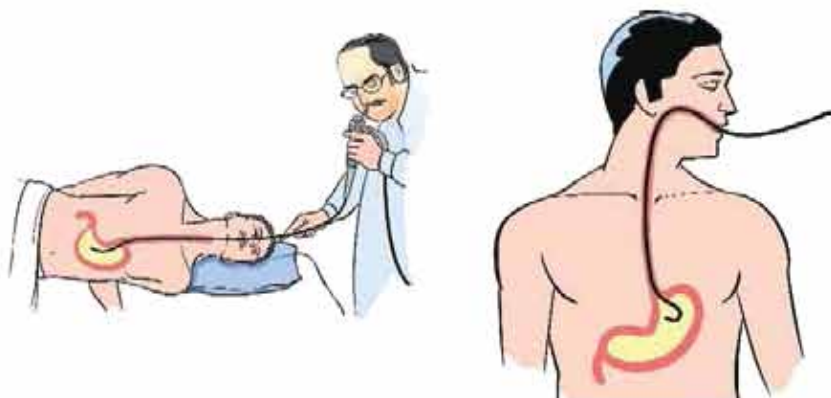

Figure 14.09: Process of seeing the inside of stomach by endoscopy

There are two transparent tubes in an endoscope. Bright light is projected into the patient's internal organ through a tube from the outside, it is done with the help of optical fibers. Light undergoes total internal reflection inside the fiber and so the tube does not need to remain straight, and can be twisted and turned. After the damaged or diseased organ of the body is lit up, an image of that area can be seen through the second tube. To see anything, the body needs to remain in a straight line, but it is not possible to look at the interior part of the organ inside the body in a straight line. That is why, optical fibers are used (where total internal reflection of light takes place) and thus the light can go through curved paths. To see a specific region inside the body precisely, a very narrow bundle of 5 to 10 thousand optical fibers is used. As each of the fibers carries the image of a point, a perfect and complete image can be seen. As the optical fibers are very narrow, the cross-section of the bundle formed by 5 to 10 thousand fibers is not more than a few millimeters.

At present, due to very small CCD camera technology, a small camera is placed at the tip of the endoscope tube, which can be inserted into the body directly and a video signal can be seen. Using endoscopy, doctors can examine any kind of

irritation, injury, inflammation or abnormal cell growth. The organs which are investigated using an endoscope are –

- a) Central partition of the lung and chest
- b) Stomach, small and large intestine or colon
- c) Female reproductive organ
- d) Abdomen and pelvis
- e) Internal part of the urethra
- f) Nasal cavity, paranasal sinuses and ear.

During endoscopy, as a narrow tube is directly entered into the injured organ, a sample of that injured area can be collected by it, and it is possible to do some surgeries using endoscope.

14.4.7 ECG

ECG is the abbreviation of the word Electro Cardiogram. The electrical and muscular functions of the human heart can be observed by doing ECG. We know that, without any external stimuli, the human heart can generate small electrical signals and these signals spreads through the heart muscle, and thus the heart

beat occurs. We can detect this electrical signal using ECG machine (Figure 14.10). The beat rate and rhythmicity of the heart can be measured using this machine. ECG signals give indirect evidence of blood flow in the heart.

Electrodes are attached to the patient's body to receive the electrical signals during ECG examination. Two electrodes

are placed on the two hands, two on the two legs, and six on the heart adjacent area of the chest. Electrical signals are collected from each of the electrodes. When these signals are printed, it is called an electrocardiogram (Figure: 14.11).

The electrical signals obtained from each of the electrodes of a healthy person have a normal pattern. If an abnormality develops in the heart of someone, then the signals obtained from the electrodes will be different from the normal pattern.



Figure 14.10: ECG machine

Generally a ECG is done to detect the cause of disease when a person experiences palpitation, irregular or rapid heart rate, or chest pain. Besides, ECG is also done as a regular checkup or before a major surgery.



Figure 14.11: Electrical signal obtained from ECG machine

ECG is done for the following abnormal conditions of the heart

1. Irregular heart beat i.e. fast or slow heart beats
2. If a heart attack occurs
3. If the heart gets dilated

Though an ECG machine is a very simple machine, it is extensively used for treatment purposes, since by using this we can get important information about the heart condition.

14.4.8 ETT

The abbreviation of Exercise Tolerance Test is ETT. Doing ECG during exercise is called ETT.

The electrical signals obtained from the heart during rest do not always depict the actual condition of the heart. If the patient undergoes excess physical stress or exercise, the heart faces excess pressure. Then, analyzing the electrical activity, beat rate and rhythmicity, the partial blockage of the coronary artery of the heart can be detected through ETT. While doing ETT, to subject the patient to excess physical work, he or she has to walk on a treadmill or paddle a stationary cycle. During the test, the speed of the cycle is increased gradually or the slope of the treadmill is increased and to see the reaction of the patient's heart to this excess work. ECG is then recorded. Generally, a doctor constantly monitors the patient's condition.

A doctor can decide about the treatment of the patient by analyzing the changes that occur in the heart, and identifying them in ECG recordings while exercise is done during the ETT test.

14.5 Physics in Treatment

14.5.1 Radio Therapy

The word radiotherapy is an abbreviation of the word 'Radiation Therapy'. Radiotherapy is the use of radioactive radiation in the treatment of some diseases. It is used in the treatment of cancer. Generally, high energy X-ray is used to destroy cancer cells in radiotherapy. This X-ray is used to destroy the DNA of the cancer cells and thus destroy their ability to multiply. Radiotherapy is used to reduce the size of a tumor before surgery or to destroy the remaining part of the tumor after surgery.

To administer treatment from outside using radiotherapy, a linear accelerator is

used to create high energy X-ray. The radioactive beam is sent targeting the area of the body with the tumor (Figure 14.12). The beam not only destroys the cancer cells but also destroys their ability to divide. Some adjacent healthy cells also get destroyed as the beam cannot be solely directed towards the cancer affected area, but once radiotherapy is stopped, the healthy cells become active again.



Figure 14.12: Radiotherapy Machine

14.5.2 Isotopes and Their Uses

You know that if the number of neutrons in a nucleus of an element is different, then this is called an isotope of that element. In nature, the different isotopes of many elements are found to be radioactive. Again, radioactive isotopes can also be made by nuclear reactions. Very often, radioactive isotopes are used in treatment. These isotopes can be used to diagnose diseases as well as in the treatment of diseases.

Sometimes, in some organs of the human body, some special compounds becomes attached. Important information about the organ can be found out by

analyzing the amount of the compound. To determine the amount of the compound, a certain atom of that compound is replaced by its radioactive isotope, and thus from the radiation of the radioactive isotope, the amount of that compound in that organ can be determined. Generally, this isotope radiates gamma ray and this gamma ray can be detected from the outside.

An amazing example of the use of radioactive isotopes is PET or Positron Emission Tomography, where the radioactive isotope radiates positrons. You know that a positron is the antiparticle of an electron and, combining with electrons, it transforms into energy. This energy is radiated as two gamma rays and goes in two opposite directions. Thus detecting these two oppositely directed gamma rays, the place from where the positron was emitted can be determined. In this way we can not only determine the existence of the positron making but can also find out where and how much of the positron is present. By emitting a positron inside glucose and by attaching its isotope, we can determine how much glucose is present, and where, inside the brain. From this information, at a particular time, we can also determine which region of the brain becomes more active and uses more glucose (Figure 14.13). PET process has played a revolutionary role in discovering the functioning processes of the brain.

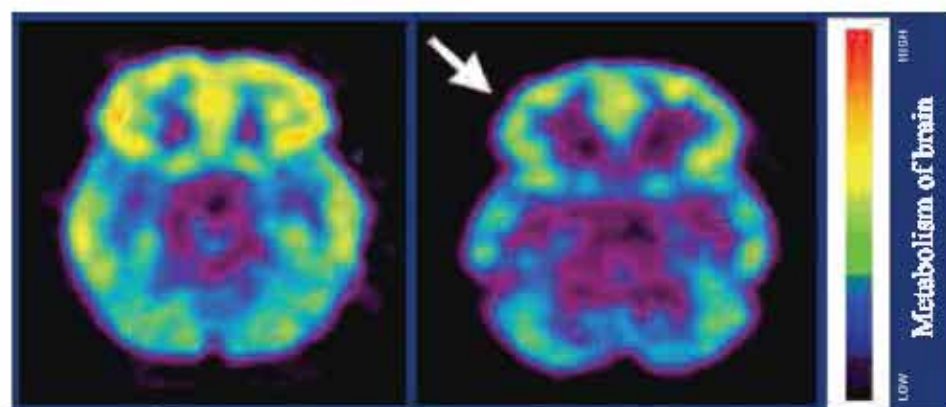

Figure 14.13: Image of the active regions of a normal and a cocaine addicted person's brain by PET scan

Besides diagnosing diseases or detecting the functioning processes of organs, radioactive isotopes are also used for treatment of diseases. Cobalt-60 (^{60}Co) is a gamma ray radiating isotope. Using this isotope, cancer affected cells are destroyed using gamma rays. Iodine-131 (^{131}I) is used in the treatment of the thyroid gland; it is so effective in the treatment of the thyroid, that now-a-days, thyroid surgeries are no longer essential.

In addition to this, phosphate with radioactive isotope Phosphorus-32 (^{32}P) is used in the treatment of blood cancer (Leukemia).



Exercise



General questions

1. Do the physical and biological worlds follow different rules?
2. How was Bio-physics originated?
3. Why can the laws of physics be applied to the living world?
4. Describe the contributions of Jagdishchandra Bose to physics.
5. What are his contributions in Bio-physics?
6. The human body sometimes functions as a machine. Explain
7. Human body is an organic machine- give arguments in its favour.
8. How can the instruments invented by physics be used for treatment purposes?
9. Name some instruments used for diagnosis of diseases.
10. What is X-ray? Write down its applications in diagnosis of diseases and their treatments.
11. How does ultrasonography identify diseases?
12. Describe the images found by MRI.
13. Which diseases can be identified by ECG?
14. For what purposes is an endoscopy machine is used?

15. Why is radiotherapy used in the field of treatment?
16. ETT is a kind of ECG- describe.
17. In which cases is an angiogram done?
18. What is an isotope? For what purposes is it used in treatment?



Multiple choice questions

Put tick mark (✓) on correct answer

1. Which of the following is related to scientist Jagadishchandra Bose?
 - i. establishment of Bose Mandir
 - ii. uses of radioactive isotope
 - iii. invention of crescograph

Which of the following is true?

- | | |
|---------------|-------------------|
| (a) i | (b) i and ii |
| (c) i and iii | (d) i, ii and iii |
2. The reason behind the clear image of bones in X-ray film-

(a) bone is non-penetrable by X-ray	(b) muscles are non-penetrable by X-ray
(c) wavelength is very large	(d) high penetrating capacity
 3. The technology used to examine blockage in a fine blood vessel-

(a) angiogram	(b) angioplasty
(c) ETT	(d) ECG
 4. How is the rate of heart beat and rhythm measured?
 - (a) identifying electrical signals
 - (b) using X-ray
 - (c) by nuclear magnetic resonance
 - (d) using sound wave



Creative questions

1. Binu's aunt is going to be a mother. She goes to doctors regularly for check-up. The doctor advised her to undergo a test to know the exact position and size of the fetus. She took the test using ultrasonography, and the doctor has got a clear concept about the fetus through it.

- What is the elaborated form of MRI?
- Why are isotopes variants of a definite element?
- Discuss the role of ultrasonography to get a clear idea about the fetus.
- Is it possible to perform this test with the help of other medical technology? State logic in favour of your answer.

2. Examining the X-ray report of a patient suffering from cough for a long time, the doctor advised him to do a CT scan. The doctor also prescribed some medicine to be taken regularly and recommended a follow up after seven days.

- What is X-ray?
- Why is ultrasonography not done instead of X-ray?
- For the patient, how will a CT scan be helpful? Explain.
- Evaluate the possibility of doing MRI instead of CT scan for the patient.



রূপপুর পারমাণবিক বিদ্যুৎ কেন্দ্র: 'শেখ হাসিনার উদ্যোগ, ঘরে ঘরে বিদ্যুৎ'

বিদ্যুৎ উৎপাদনে পারমাণবিক প্রযুক্তি সর্বাধিক নিরাপদ ও পরিবেশ বান্ধব প্রযুক্তি। বিশ্বে মোট বিদ্যুৎ চাহিদার ১০ ভাগ আসে পারমাণবিক প্রযুক্তি খাত থেকে। বাংলাদেশও বিশ্বের অন্যান্য উন্নত দেশের মতো ক্রমবর্ধমান বিদ্যুৎ চাহিদা মেটানোর জন্য স্বল্প মূল্যে উৎপাদিত পরিবেশ বান্ধব এই প্রযুক্তির ব্যবহার করার প্রয়াসে পাবনা জেলার রূপপুরে দুই ইউনিট বিশিষ্ট পারমাণবিক বিদ্যুৎ কেন্দ্র তৈরি করছে। প্রতিটি ইউনিট প্রায় ১২০০ মেগাওয়াট বিদ্যুৎ উৎপন্ন করবে। ১৯৬১ সালে পাবনা জেলায় ৬৩২ একরের উপর এই পারমাণবিক বিদ্যুৎ কেন্দ্র গড়ে তোলার পরিকল্পনা নেওয়া হলেও তা স্থগিত হয়ে যায়। ১৯৭৪ সালে বঙ্গবন্ধু শেখ মুজিবুর রহমান পুনরায় প্রকল্পটি বাস্তবায়নের উদ্যোগ নেন। তারই ধারাবাহিকতায় বিভিন্ন পর্যায়ে অতিক্রম করে শেখ হাসিনা সরকারের উদ্যোগে ২০১৭ সালের নভেম্বরে প্রথম ইউনিট ও ২০১৮ সালে দ্বিতীয় ইউনিটের নির্মাণ কাজ শুরু হয় যা ২০২৩ বা ২০২৪ সাল থেকে বিদ্যুৎ উৎপাদনে সক্ষম হবে।

2023

Academic Year
9-10 Physics

‘কল্পনাশক্তি জ্ঞান থেকেও বেশি গুরুত্বপূর্ণ’ – অ্যালবার্ট আইনস্টাইন

দারিদ্র্যমুক্ত বাংলাদেশ গড়তে হলে শিক্ষা গ্রহণ করতে হবে
– মাননীয় প্রধানমন্ত্রী শেখ হাসিনা

তথ্য, সেবা ও সামাজিক সমস্যা প্রতিকারের জন্য ‘৩৩৩’ কলসেন্টারে ফোন করুন

নারী ও শিশু নির্যাতনের ঘটনা ঘটলে প্রতিকার ও প্রতিরোধের জন্য ন্যাশনাল হেল্পলাইন সেন্টারে
১০৯ নম্বর-এ (টোল ফ্রি, ২৪ ঘণ্টা সার্ভিস) ফোন করুন



Ministry of Education

For free distribution from academic year 2010 by the Government of the
People's Republic of Bangladesh