

Higher Mathematics

Classes Nine-Ten

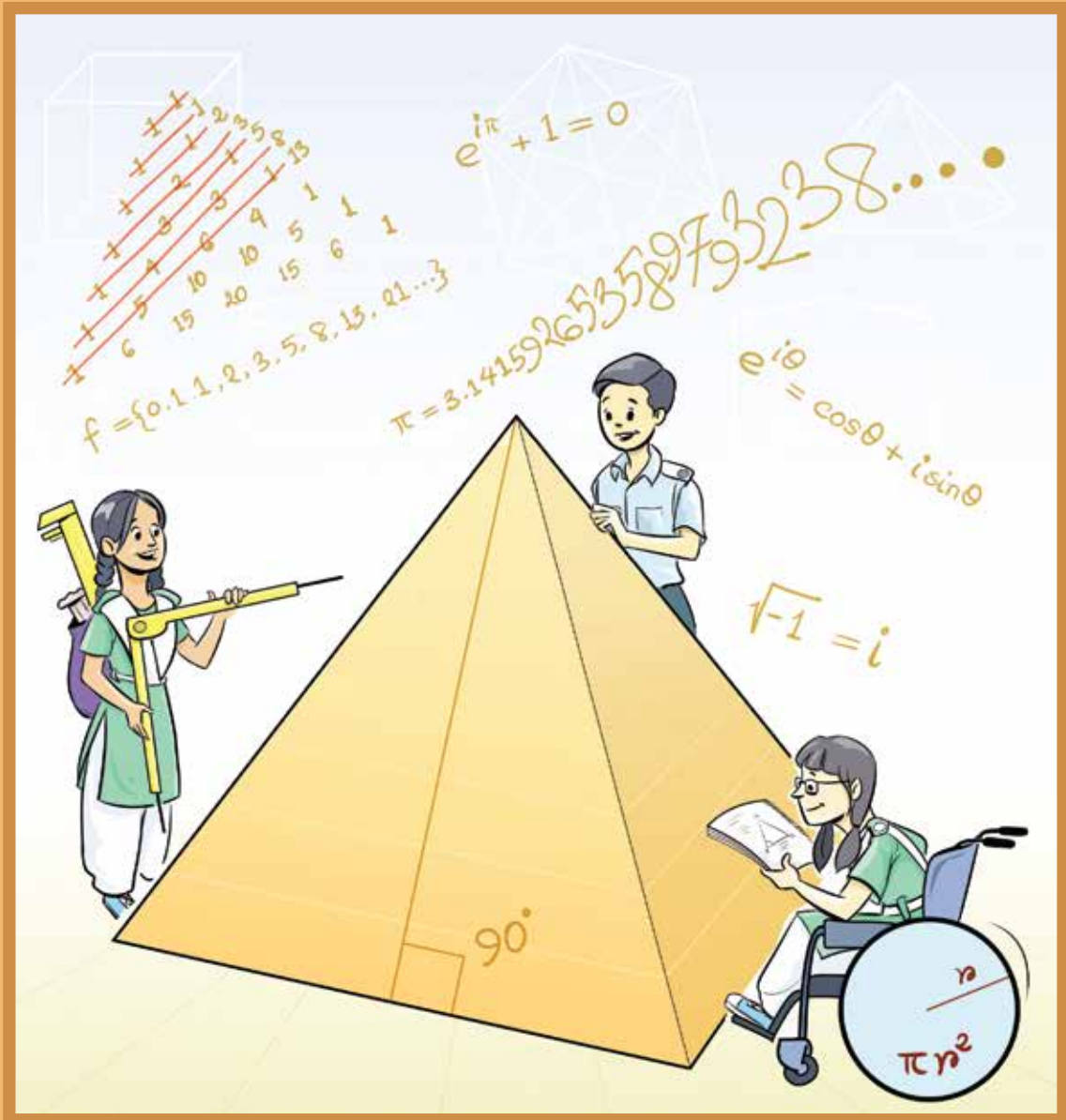

NATIONAL CURRICULUM AND TEXTBOOK BOARD, BANGLADESH



মাননীয় প্রধানমন্ত্রী শেখ হাসিনা টিকাদান কর্মসূচির সফল বাস্তবায়নের জন্য 'ভ্যাকসিন হিরো' পুরস্কার গ্রহণ করছেন।

বাংলাদেশের টিকাদান কর্মসূচিতে সফলতার স্বীকৃতিস্বরূপ প্রধানমন্ত্রী শেখ হাসিনাকে 'ভ্যাকসিন হিরো' পুরস্কার দিয়েছে গ্লোবাল এ্যালায়েন্স ফর ভ্যাক্সিনেশন এন্ড ইমুনাইজেশন (GAVI)। জাতিসংঘ সদর দপ্তরে 'ইমুনাইজেশনের ক্ষেত্রে বাংলাদেশের রাজনৈতিক নেতৃত্বের স্বীকৃতি' শীর্ষক অনুষ্ঠানে প্রধানমন্ত্রীর হাতে এ পুরস্কার তুলে দেন GAVI এর বোর্ড সভাপতি ড. এনগোজি অকোনজো ইবিলা এবং সংস্থাটির প্রধান নির্বাহী কর্মকর্তা সেথ ফ্রাংকলিন বার্কলে। প্রতিটি শিশুকে টিকাদান কর্মসূচির আওতায় এনে শিশুদের জীবন রক্ষাকারী জরুরি টিকাদান সম্পন্ন করার সুনির্দিষ্ট লক্ষ্যমাত্রা অর্জনই ছিল এই পুরস্কার প্রদানের বিবেচ্য বিষয়।

Prescribed by the National Curriculum and Textbook Board
as a textbook for classes nine-ten from the academic year 2013

Higher Mathematics

Classes Nine-Ten

**Reviewed and modified
for making the contents easy and accessible**

by

Dr. Mohammed Kaykobad
Dr. Muhammad Abdul Hakim Newton
Dr. Rifat Shahriyar
Dr. Atif Hasan Rahman
Dr. Amulya Chandra Mandal
Dr. Muhammed Zafar Iqbal

Last edition written and translated by

Dr. Amulya Chandra Mandal
Dr. Md. Abdus Samad
Dr. Md. Abdul Halim
Dr. Shahdat Ali Mallik
Dr. Monibur Rahman Chowdhury

Last edition edited by

Dr. Md. Abdul Matin
Dr. Md. Ainul Islam

Retranslated by

Abir Mohammad
Abdullah Ibn Mahmud
Sarah Siddiqua
Afia Afrin

Published By
National Curriculum and Textbook Board

69-70 Motijheel Commercial Area, Dhaka

[All rights reserved by the publisher]

First Publication : September, 2012

Revised Edition : November, 2017

Reprint : , 2022

Cover: Nasreen Sultana Mitu

Illustration: Dr. Muhammad Abdul Hakim Newton

Font: Md. Tanbin Islam Siyam

Book Design: Dr. Muhammad Abdul Hakim Newton &
Dr. Atif Hasan Rahman

Page Makeup: Dr. Rifat Shahriyar &
Dr. Md. Shamsuzzoha Bayzid

Overall Coordination: Mohammed Jaynal Abedin

For free distribution by the Government of the People's Republic of Bangladesh

Printed By:

Preface

The aim of secondary education is to make the learners fit for entry into higher education by flourishing their latent talents and prospects with a view to building the nation with the spirit of the Language Movement and the Liberation War. To make the learners skilled and competent citizens of the country based on the economic, social, cultural and environmental settings is also an important issue of secondary education.

The textbooks of secondary level have been written and compiled according to the revised curriculum 2012 in accordance with the aims and objectives of National Education Policy-2010. Contents and presentations of the textbooks have been selected according to the moral and humanistic values of Bengali tradition and culture and the spirit of Liberation War 1971 ensuring equal dignity for all irrespective of caste and creed of different religions and sex.

Honorable Prime Minister, Government of the People's Republic of Bangladesh, Sheikh Hasina expressed her firm determination to make the country free from illiteracy and instructed the concerned authority to give free textbooks to every student of the country. National Curriculum and Textbook Board started to distribute textbooks free of cost since 2010 according to her instruction. In its continuation, this textbook has been reviewed and updated with a view to create a developed and resourceful Bangladesh keeping vision 2041 ahead.

Higher Mathematics, in line with Mathematics for classes nine and ten, plays an important role as a powerful instrument to visualise real features of abstract ideas as well as to enhance thinking skills. The use and application of higher mathematics is everywhere in the huge development of ICT and Science. Considering these things, the book Higher Mathematics has been introduced in the secondary level. In this case, sincere attempts have been taken to make the book easy and entertaining, giving due emphasis on the understandability of the students.

Considering the challenges and commitments of 21st century and following the revised curriculum the textbook has been written. The textbook has been revised and re-edited by a group of prominent educationist to make it learner friendly in 2017.

I thank sincerely all who were involved in the process of revision, writing, editing, art and design of the textbook for their intellectual labour.

Professor Md. Farhadul Islam

Chairman

National Curriculum and Textbook Board, Bangladesh

Contents

Chapter		Page
1	Set and Function	1
2	Algebraic Expression	41
3	Geometry	68
4	Geometric Constructions	90
5	Equation	104
6	Inequality	133
7	Infinite Series	147
8	Trigonometry	158
9	Exponential and Logarithmic Function	205
10	Binomial Expansion	236
11	Coordinate Geometry	252
12	Planar Vector	288
13	Solid Geometry	305
14	Probability	326

Chapter 1

Set and Function

The concept and use of set are especially important in mathematics. For this reason set has been discussed in Mathematics book of class VIII and IX-X. In this chapter, we go beyond the materials covered there.

After completing the chapter, the students will be able to –

- ▶ form universal sets, subsets, complement of a set, power sets;
- ▶ form union, intersection and difference of sets;
- ▶ prove the properties of set operations;
- ▶ describe equivalent sets and explain the concept of infinite set;
- ▶ explain the formula for determining the union set, power set and verify it with the help of Venn diagram and examples;
- ▶ solve real life problems by using set operations and formulas;
- ▶ explain the concept of relations and functions by using sets;
- ▶ determine the domain and range of functions;
- ▶ explain one-one function, onto function, one-one and onto functions with examples;
- ▶ explain inverse function;
- ▶ verify whether a relation is a function or not with the help of graphs;
- ▶ draw the graphs of relations and functions.

Set

Any well-defined collection of objects of the real world or of the conceptual realm is called **Set**. For example, $S = \{1, 4, 9, 16, 25, 36, 49, 64, 81, 100\}$ denotes the set of square of natural numbers which are less than 10. The process of expressing set in this method is called **Tabular Method**. Each of the objects forming a set is called **Element** of that set. If x is an element of a set A then we write $x \in A$ and if

x is not an element of a set A then we write $x \notin A$. The aforementioned set S is written as $S = \{x : x \text{ is square number not greater than } 100\}$. This method is called **Set Builder Method**.

Activity: In the above discussion 1) Explain that S is a set. 2) Express S in another way.

Universal Set

Suppose,

$$S = \{x : x \text{ is a positive integer and } 5x \leq 16\}$$

$$T = \{x : x \text{ is a positive integer and } x^2 < 20\}$$

$$P = \{x : x \text{ is a positive integer and } \sqrt{x} \leq 2\}$$

The elements of these three sets are formed by the set $U = \{x : x \text{ is a positive integer}\}$. U can be considered as the universal set for sets S, T, P .

If all the sets under discussion are included in a particular set, that particular set is called the **universal set**.

Some Special Number Sets

$N = \{1, 2, 3, \dots\}$, that is the set of all natural numbers or positive integers.

$Z = \{\dots, -2, -1, 0, 1, 2, 3, \dots\}$, that is the set of all integers.

$Q = \{x : x = \frac{p}{q}, \text{ Where } p \text{ is any integer and } q \text{ is any positive integers}\}$ that is the set of all rational numbers.

$R = \{x : x \text{ is a real number}\}$ So the set of all real numbers.

Subset

If A and B are sets then A will be called the **subset** of B if and only if every element of A are elements of B and it will be expressed as $A \subseteq B$. For example, $A = \{2, 3\}$ is the subset of $B = \{2, 3, 5, 7\}$. If A is not the subset of B then $A \not\subseteq B$ is written. For example, $A = \{1, 3\}$ is not the subset of $B = \{2, 3, 5, 7\}$.

Example 1. If $A = \{x : x \text{ is a positive integer}\}$, $B = \{0\}$ and $X = \{x : x \text{ is an integer}\}$, then what is the relationship between A, B and X ?

Solution: Here, $A \subseteq X$, $B \subseteq X$, $B \not\subseteq A$.

Activity: Suppose $X = \{x : x \text{ integer}\}$.

- 1) Considering X as universal set, describe three subsets of X .
- 2) Describe two subsets of X where none of them are subsets of one another.

Empty Set

Sometimes such a set is considered which has no element. This kind of set is regarded as **empty set** and expressed as \emptyset or $\{\}$.

Example 2. $\{x : x \text{ is a real number and } x^2 < 0\}$ is an empty set, because the square of any real number can never be negative.

Example 3. $F = \{x : x, \text{ African countries who won the FIFA world cup till 2014}\}$ is an empty set, because no African country has ever won the FIFA world cup till 2014.

Equality of Sets

If A and B sets have the same elements then A and B are regarded to be equal and it is expressed as $A = B$. For example, $A = \{1, 2, 3, 4\}$, $B = \{1, 2, 2, 3, 4, 4, 4\}$. It is to be noted that even though one element appears in a set repeatedly, it is considered same as appearing once. $A = B$ if and only if $A \subseteq B$ and $B \subseteq A$. This information is extremely important to prove the equality of sets.

Proper Subset

A is the **proper subset** of B if and only if $A \subseteq B$ and $A \neq B$. That means, every element of A is also an element of B and B has at least one element which is not an element of A . For example, $A = \{1, 2\}$, $B = \{1, 2, 3\}$. To express A as a proper subset of B , $A \subset B$ is written.

- 1) For any set A , $A \subseteq A$. This is because $x \in A \implies x \in A$.
- 2) For any set A , $\emptyset \subseteq A$. This is because if $\emptyset \subseteq A$ do not happen, \emptyset will have one element x that A will not have. But this is never true because \emptyset is an empty set. So, $\emptyset \subseteq A$. It should be mentioned that empty set or \emptyset is a proper subset of any set.

Difference of Sets

If A and B are sets, $A \setminus B$ is $\{x : x \in A \text{ and } x \notin B\}$.

$A \setminus B$ is called A **delete** B and the elements of A that are present in B are discarded from A to form $A \setminus B$. $A \setminus B \subseteq A$.

Example 4. If $A = \{0, 1, 2, 3, 4, 5, 6, 7, 8, 9\}$ and $B = \{0, 2, 4, 6, 8, 10\}$ then $A \setminus B = \{1, 3, 5, 7, 9\}$.

Complementary Set

If U is an universal set and $A \subseteq U$, then the complementary set of A is $U \setminus A$.

So, $U \setminus A = \{x : x \in U \text{ and } x \notin A\}$.

If the elements of A is discarded from the universal set, then we get the complementary set of A and it will be expressed as A' or A^c .

Example 5. If universal set U is the set of all integers and A is the set of all negative integers, then (with respect to U), the complementary set of A will be A' or $A^c = \{0, 1, 2, 3, \dots\}$

Power Set

The set of all subsets of A is called the **power set** of A and it is expressed as $P(A)$. It is to be noted that $\emptyset \subseteq A$. For this reason, \emptyset is also an element of $P(A)$.

A Set	$P(A)$ Power Set
$A = \emptyset$	$P(A) = \{\emptyset\}$
$A = \{a\}$	$P(A) = \{\emptyset, A\}$
$A = \{a, b\}$	$P(A) = \{\emptyset, \{a\}, \{b\}, A\}$
$A = \{a, b, c\}$	$P(A) = \{\emptyset, \{a\}, \{b\}, \{c\}, \{a, b\}, \{a, c\}, \{b, c\}, A\}$

Activity:

- If $U = \{1, 2, 3, 4, 5, 6, 7, 8, 9, 10\}$, write down the following sets in tabular method:
 - $A = \{x : x \in U, 5x > 37\}$
 - $B = \{x : x \in U, x + 5 < 12\}$
 - $C = \{x : x \in U, 6 < 2x < 17\}$
 - $D = \{x : x \in U, x^2 < 37\}$
- If $U = \{x : x \in \mathbb{Z}^+, 1 \leq x \leq 20\}$, write down the following sets in tabular method:
 - $A = \{x : x, \text{ is a multiple of } 2\}$
 - $B = \{x : x, \text{ is a multiple of } 5\}$
 - $C = \{x : x, \text{ is a multiple of } 10\}$

In the light of your work, ascertain which among $C \subset A$, $B \subset A$, $C \subset B$ are true or false?

3) If $A = \{a, b, c, d, e\}$, then find out $P(A)$.

Example 6. If $A = \{a, b\}$ and $B = \{b, c\}$, show that $P(A) \cup P(B) \subseteq P(A \cup B)$.

Solution: Here, $P(A) = \{\emptyset, \{a\}, \{b\}, \{a, b\}\}$, $P(B) = \{\emptyset, \{b\}, \{c\}, \{b, c\}\}$.

$\therefore P(A) \cup P(B) = \{\emptyset, \{a\}, \{b\}, \{c\}, \{a, b\}, \{b, c\}\}$.

$A \cup B = \{a, b, c\}$, $P(A \cup B) = \{\emptyset, \{a\}, \{b\}, \{c\}, \{a, b\}, \{a, c\}, \{b, c\}, \{a, b, c\}\}$.

So, $P(A) \cup P(B) \subseteq P(A \cup B)$.

Activity:

- 1) If $A = \{1, 2, 3\}$, $B = \{1, 2\}$, $C = \{2, 3\}$ and $D = \{1, 3\}$, then prove, $P(A) = \{A, B, C, D, \{1\}, \{2\}, \{3\}, \emptyset\}$.
- 2) If $A = \{1, 2\}$ and $B = \{2, 5\}$, then prove,
 - (1) $P(A) \cap P(B) = P(A \cap B)$,
 - (2) $P(A) \cup P(B) \neq P(A \cup B)$.

Venn Diagram

Sometimes expressing set related information in diagrams is quite convenient. These diagrams are named **Venn diagram** after the name of John Venn (1834 – 1923). This has been discussed briefly in the Mathematics book.

Example 7. The Venn diagram of A' , which is the complementary set of A with respect to the universal set U :

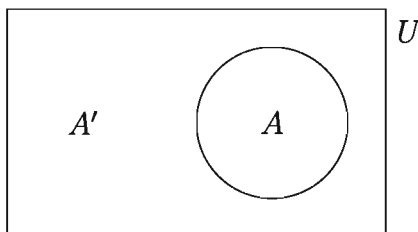

Union of Sets

If A and B are sets then their **union of sets** is $A \cup B = \{x : x \in A \text{ or } x \in B\}$.

So, the set formed by the elements of both A and B is called $A \cup B$.

Intersection of Sets

If A and B are sets, their **intersection of sets** is $A \cap B = \{x : x \in A \text{ and } x \in B\}$.

That means, the set formed by all common elements of A and B is called $A \cap B$.

Example 8. Two subsets of universal set $U = \{0, 1, 2, 3, 4, 5, 6, 7, 8, 9\}$ are $A = \{x : x \text{ prime number}\}$ and $B = \{x : x \text{ odd number}\}$.

So $A = \{2, 3, 5, 7\}$ and $B = \{1, 3, 5, 7, 9\}$.

Therefore, $A \cup B = \{1, 2, 3, 5, 7, 9\}$, $A \cap B = \{3, 5, 7\}$,

$$A' = \{0, 1, 4, 6, 8, 9\}, B' = \{0, 2, 4, 6, 8\},$$

$$A' \cup B' = \{0, 1, 2, 4, 6, 8, 9\}, A' \cap B' = \{0, 4, 6, 8\},$$

$$(A \cap B)' = \{0, 1, 2, 4, 6, 8, 9\}, (A \cup B)' = \{0, 4, 6, 8\}.$$

Activity: Show the examples mentioned above in Venn Diagram.

Disjoint Set

If A and B are such sets that $A \cap B = \emptyset$, then A and B are called **disjoint sets**.

Example 9. If $A = \{x : x \text{ positive integer}\}$ and $B = \{x : x \text{ negative real number}\}$ then A and B are disjoint sets, $A \cap B = \emptyset$.

Example 10. If $A = \{x : x \in R \text{ and } 0 \leq x \leq 2\}$ and $B = \{x : x \in N \text{ and } 0 \leq x \leq 2\}$ then $B \subseteq A$, $A \cup B = A$, $A \cap B = B = \{1, 2\}$.

Example 11. If $A = \{x : x \in R \text{ and } 1 \leq x \leq 2\}$ and $B = \{x : x \in R \text{ and } 0 < x < 1\}$, $A \cup B = \{x : x \in R \text{ and } 0 < x \leq 2\}$ and $A \cap B = \emptyset$, So, A and B are disjoint sets.

Cartesian Product Set

The Cartesian Product Set of two sets A and B is $A \times B = \{(x, y) : x \in A \text{ and } y \in B\}$.

Example 12. $A = \{1, 2\}$, $B = \{a, b, c\}$ are two sets. So the Cartesian Product of these two sets is $A \times B = \{(1, a), (1, b), (1, c), (2, a), (2, b), (2, c)\}$.

Some Propositions of Set

Here in every case U is the universal set and sets A, B, C are the subsets of U .

1) Commutative Law

$$(1) A \cup B = B \cup A$$

$$(2) A \cap B = B \cap A$$

2) Associative Law

$$(1) (A \cup B) \cup C = A \cup (B \cup C)$$

$$(2) (A \cap B) \cap C = A \cap (B \cap C)$$

3) Distributive Law

$$(1) A \cup (B \cap C) = (A \cup B) \cap (A \cup C)$$

$$(2) A \cap (B \cup C) = (A \cap B) \cup (A \cap C)$$

4) De Morgan's Law

$$(1) (A \cup B)' = A' \cap B'$$

$$(2) (A \cap B)' = A' \cup B'$$

5) Other Formulas

$$(1) A \cup A = A, A \cap A = A$$

$$(2) A \cup \emptyset = A, A \cap \emptyset = \emptyset$$

$$(3) A \cup U = U, A \cap U = A$$

$$(4) A \subseteq B \implies B' \subseteq A'$$

$$(5) A \subseteq B \implies A \cup B = B$$

$$(6) A \subseteq B \implies A \cap B = A$$

$$(7) A \subseteq A \cup B$$

$$(8) A \cap B \subseteq A$$

$$(9) A \setminus B = A \cap B'$$

Verification of the Two Propositions of the Commutative Law

The shaded area of the following left diagram denotes both $A \cup B$ and $B \cup A$. So in this case, we see that $A \cup B = B \cup A$. On the other hand, the shaded area of the right sided diagram shows both $A \cap B$ and $B \cap A$. So in this case, it is seen that $A \cap B = B \cap A$.

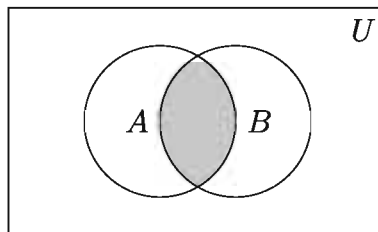
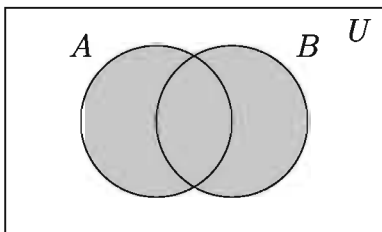

Here the verification shown above is done with the help of Venn Diagram. Now let's see this with a definite example.

Suppose, $A = \{1, 2, 4\}$ and $B = \{2, 3, 5\}$ are two sets.

So, $A \cup B = \{1, 2, 4\} \cup \{2, 3, 5\} = \{1, 2, 3, 4, 5\}$.

Again, $B \cup A = \{2, 3, 5\} \cup \{1, 2, 4\} = \{1, 2, 3, 4, 5\}$.

So in this case, $A \cup B = B \cup A$.

On the other hand, $A \cap B = \{1, 2, 4\} \cap \{2, 3, 5\} = \{2\}$

and $B \cap A = \{2, 3, 5\} \cap \{1, 2, 4\} = \{2\}$.

So here, $A \cap B = B \cap A$.

Verification of the Two Propositions of the Associative Law

The shaded area of the following left diagram denotes both $A \cup (B \cup C)$ and $(A \cup B) \cup C$. So in this case $A \cup (B \cup C) = (A \cup B) \cup C$. The shaded area of the right sided diagram shows $A \cap (B \cap C)$ and $(A \cap B) \cap C$. So here we can say that $(A \cap B) \cap C = A \cap (B \cap C)$.

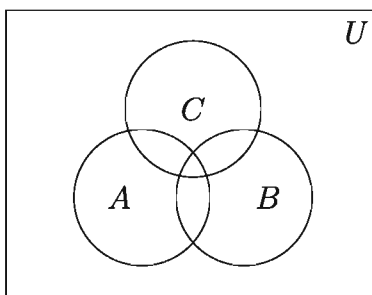
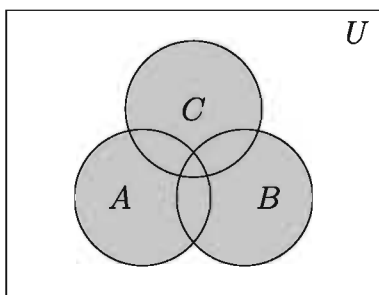

Here the verification shown above is done with the help of Venn Diagram. Now let's see this with a definite example.

Suppose, $A = \{a, b, c, d\}$, $B = \{b, c, f\}$ and $C = \{c, d, g\}$.

So, $B \cup C = \{b, c, f\} \cup \{c, d, g\} = \{b, c, d, f, g\}$

and $A \cup (B \cup C) = \{a, b, c, d\} \cup \{b, c, d, f, g\} = \{a, b, c, d, f, g\}$.

Again, $A \cup B = \{a, b, c, d\} \cup \{b, c, f\} = \{a, b, c, d, f\}$

and $(A \cup B) \cup C = \{a, b, c, d, f\} \cup \{c, d, g\} = \{a, b, c, d, f, g\}$.

So in this case, $(A \cup B) \cup C = A \cup (B \cup C)$.

Again, $B \cap C = \{b, c, f\} \cap \{c, d, g\} = \{c\}$

and $A \cap (B \cap C) = \{a, b, c, d\} \cap \{c\} = \{c\}$.

Again, $A \cap B = \{a, b, c, d\} \cap \{b, c, f\} = \{b, c\}$

and $(A \cap B) \cap C = \{b, c\} \cap \{c, d, g\} = \{c\}$.

So here, $A \cap (B \cap C) = (A \cap B) \cap C$.

Activity: Verify the distributive laws for the sets $A = \{1, 2, 3, 6\}$, $B = \{2, 3, 4, 5\}$ and $C = \{3, 5, 6, 7\}$. Show the proof in Venn diagrams for each set.

Observation: Each of the operations of union and intersection of sets is distributive with respect to one another.

Proposition 1 (De Morgan's Law). For any subset A and B of a universal set U ,

$$1) (A \cup B)' = A' \cap B' \qquad 2) (A \cap B)' = A' \cup B'$$

Proof:(The proof of only the first part is shown below. Prove the second one yourself.)

Suppose, $x \in (A \cup B)'$. So, $x \notin A \cup B$.

$$\implies x \notin A \text{ and } x \notin B \implies x \in A' \text{ and } x \in B' \implies x \in A' \cap B'$$

$$\therefore (A \cup B)' \subseteq A' \cap B'.$$

Again, suppose, $x \in A' \cap B'$. So, $x \in A'$ and $x \in B'$.

$$\implies x \notin A \text{ and } x \notin B \implies x \notin A \cup B \implies x \in (A \cup B)'$$

$$\therefore A' \cap B' \subseteq (A \cup B)'.$$

Therefore, $(A \cup B)' = A' \cap B'$.

Proposition 2. For any subset A and B of a universal set U , $A \setminus B = A \cap B'$

Proof: Suppose, $x \in A \setminus B$. So, $x \in A$ and $x \notin B$.

$$\implies x \in A \text{ and } x \in B' \implies x \in A \cap B'$$

$$\therefore A \setminus B \subseteq A \cap B'.$$

Again suppose, $x \in A \cap B'$. So, $x \in A$ and $x \in B'$.

$$\implies x \in A \text{ and } x \notin B \implies x \in A \setminus B$$

$$\therefore A \cap B' \subseteq A \setminus B.$$

So, $A \setminus B = A \cap B'$.

Proposition 3. For any set A, B, C we have,

$$1) A \times (B \cap C) = (A \times B) \cap (A \times C)$$

$$2) A \times (B \cup C) = (A \times B) \cup (A \times C)$$

Proof: (The proof of only the first part is shown below. Prove the next one yourself.)

According to the definition, $A \times (B \cap C)$

$$= \{(x, y) : x \in A, y \in B \cap C\}$$

$$= \{(x, y) : x \in A, y \in B \text{ and } y \in C\}$$

$$= \{(x, y) : (x, y) \in A \times B \text{ and } (x, y) \in A \times C\}$$

$$= \{(x, y) : (x, y) \in (A \times B) \cap (A \times C)\}$$

$$\therefore A \times (B \cap C) \subseteq (A \times B) \cap (A \times C)$$

Again, $(A \times B) \cap (A \times C)$

$$= \{(x, y) : (x, y) \in A \times B \text{ and } (x, y) \in A \times C\}$$

$$= \{(x, y) : x \in A, y \in B \text{ and } x \in A, y \in C\}$$

$$= \{(x, y) : x \in A, y \in B \cap C\}$$

$$= \{(x, y) : (x, y) \in A \times (B \cap C)\}$$

$$\therefore (A \times B) \cap (A \times C) \subseteq A \times (B \cap C)$$

So, $A \times (B \cap C) = (A \times B) \cap (A \times C)$.

Some More Propositions of the Method of Sets

- 1) If A is any set $A \subseteq A$
- 2) The empty set \emptyset is the subset of any set A .
- 3) If A and B are any sets, $A = B$ provided if and only if $A \subseteq B$ and $B \subseteq A$.
- 4) If $A \subseteq \emptyset$, then $A = \emptyset$.
- 5) If $A \subseteq B$ and $B \subseteq C$ then, $A \subseteq C$.
- 6) For any set A and B , $A \cap B \subseteq A$ and $A \cap B \subseteq B$.
- 7) For any set A and B , $A \subseteq A \cup B$ and $B \subseteq A \cup B$.

Proof: Only proofs of two propositions are given. Do the others.

- 4) Given, $A \subseteq \emptyset$, also we know, $\emptyset \subseteq A$. Therefore $A = \emptyset$.

- 7) According to the definition of union of sets, $A \cup B$ consists of the common elements and all elements of A . So as per the definition of subset, $A \subseteq A \cup B$. By the same logic $B \subseteq A \cup B$.

Activity: All of the following sets can be considered as the subset of universal set U .

- 1) Show that, $A \cap (B \cap C) = (A \cap B) \cap (A \cap C)$.
- 2) Show that, $A \subset B$ if and only if any of the conditions below is fulfilled:
 - (1) $A \cap B = A$
 - (2) $A \cup B = B$
 - (3) $B' \subset A'$
 - (4) $A \cap B' = \emptyset$
 - (5) $B \cup A' = U$
- 3) Show that,
 - (1) $A \setminus B \subset A \cup B$
 - (2) $A' \setminus B' = B \setminus A$
 - (3) $A \setminus B \subset A$
 - (4) If $A \subset B$, $A \cup (B \setminus A) = B$
 - (5) If $A \cap B = \emptyset$, $A \subset B'$ and $A \cap B' = A$ and $A \cup B' = B'$
- 4) Show that,
 - (1) $(A \cap B)' = A' \cup B'$
 - (2) $(A \cup B \cup C)' = A' \cap B' \cap C'$
 - (3) $(A \cap B \cap C)' = A' \cup B' \cup C'$

One-One Correspondence

Suppose, $A = \{a, b, c\}$ is a set of three persons and $B = \{30, 40, 50\}$ is the set of their ages. Moreover, suppose, the age of a is 30 years, the age of b is 40 years and the age of c is 50 years. So it can be said that, there is an one-one correspondence between the sets A and B .

Definition 1 (One-One Correspondence). If the matching of an element of B with every element of A and an element of A with every element of B are established, such matching is called an **one-one correspondence**. The one-one correspondence between sets A and B is usually expressed as $A \leftrightarrow B$ and if any element x of the set A corresponds to the element y of the set B , we write $x \leftrightarrow y$.

Equivalent Set

let, $A = \{1, 2, 3\}$ and $B = \{a, b, c\}$ are two sets. An one - one correspondence between the sets A and B is shown in the figure below:

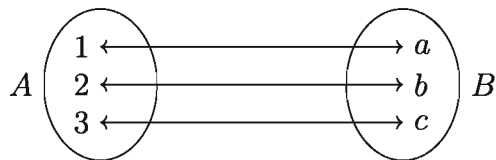

Definition 2 (Equivalent Set). Any sets A and B are regarded as **equivalent sets** if one can establish an one-one correspondence $A \leftrightarrow B$ between them. $A \sim B$ is written to indicate that A and B are equivalent. If $A \sim B$, one of them is called **equivalent** to the other. Notice that, for sets A, B and C

- 1) $A \sim A$
- 2) If $A \sim B$, then $B \sim A$
- 3) If $A \sim B$ and $B \sim C$, then $A \sim C$.

Example 13. Show that, $A = \{1, 2, 3, \dots, n\}$ and $B = \{1, 3, 5, \dots, 2n - 1\}$ are equivalent sets, where n is a natural number.

Solution: A and B are equivalent, because the two sets have an one-one correspondence as shown below:

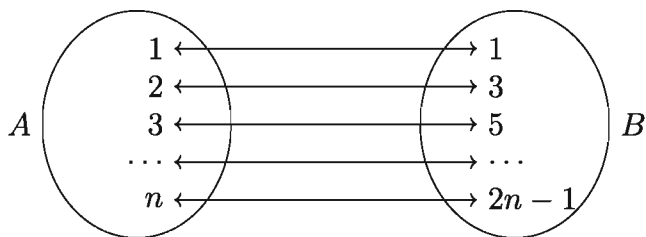

Remarks: The one-one correspondence indicated above can be described by $A \leftrightarrow B : k \leftrightarrow 2k - 1, k \in A$.

Example 14. Show that, the set of natural numbers N and the set of even natural numbers $A = \{2, 4, 6, \dots, 2n, \dots\}$, are equivalent.

Solution: $N = \{1, 2, 3, \dots, n, \dots\}$ and A are equivalent sets, because an one-one correspondence between the sets N and A can be established, which is shown below.

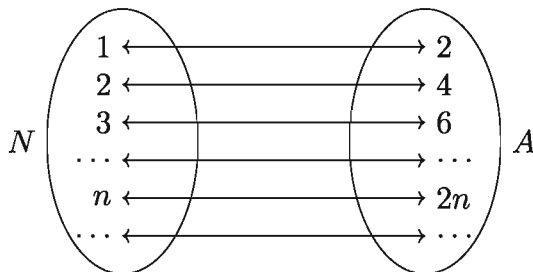

Remarks: The one-one correspondence indicated above, can be described by $N \leftrightarrow A : n \leftrightarrow 2n, n \in N$.

Observation: Empty set \emptyset is supposed to be equivalent to itself. So, $\emptyset \sim \emptyset$.

Proposition 4. Every set A is equivalent to itself. That means, $A \sim A$.

Proof: If $A = \emptyset$, it is taken $A \sim A$. On the other hand, if $A \neq \emptyset$, every element makes a one-one correspondence with x by itself to establish a one-one correspondence $A \leftrightarrow A : x \leftrightarrow x, x \in A$. So $A \sim A$.

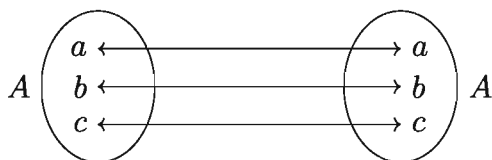

Proposition 5. If A and B are equivalent sets and B and C equivalent sets, then A and C are equivalent too.

Proof: As $A \sim B$, we can associate every element x of A with a unique element y of B . Again, since $B \sim C$, we can associate with that element y of B a unique element z of C . So we can associate the element x of A with the unique elements z of C . This association of the elements of A with the elements of C is a one-one correspondence between them. So, $A \sim C$.

Interval

If a and b are real numbers and $a < b$,

- 1) $(a, b) = \{x \in R : a < x < b\}$ is called **open interval**.
- 2) $[a, b] = \{x \in R : a \leq x \leq b\}$ is called **closed interval**.
- 3) $(a, b] = \{x \in R : a < x \leq b\}$ and $[a, b) = \{x \in R : a \leq x < b\}$ are respectively called **open-closed interval** and **closed-open interval**.

Finite and Infinite Sets

Counting the elements of the set $A = \{15, 16, 17, 18, 19, 20, 21, 22\}$, we see that A has 8 elements. This counting is completed by establishing a one-one correspondence of the set A with the set $B = \{1, 2, 3, 4, 5, 6, 7, 8\}$, as shown below:

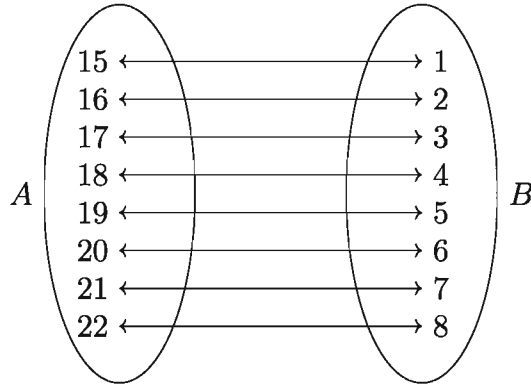

Definition 3 (Finite and Infinite Sets). A set whose elements can be fixed by counting, is called a **finite set**. If any set A is not a finite set, then it is called **infinite set**.

- 1) Empty set \emptyset is a finite set, whose number of elements is 0.
- 2) If any set A and $J_m = \{1, 2, 3, \dots, m\}$ are equivalent, where $m \in N$, then A is a finite set and the number of elements of A is m .
- 3) If A is a finite set, the number of elements of A is denoted by $n(A)$.

Note:

- 1) $J_1 = \{1\}$, $J_2 = \{1, 2\}$, $J_3 = \{1, 2, 3\}$ is the **finite subset** of N and $n(J_1) = 1$, $n(J_2) = 2$, $n(J_3) = 3$ etc. In real sense, $J_m \sim J_m$ and $n(J_m) = m$.
- 2) Only the number of elements in a finite set can be fixed. So notation $n(A)$ implies that A is a finite set.
- 3) If A and B are equivalent sets and if one of them is finite, then the other set must be finite and $n(A) = n(B)$ will hold.

Proposition 6. If A is a finite set and B is a proper subset of A , then B will be a finite set and there will be $n(B) < n(A)$.

Proposition 7. Set A is infinite if and only if there exists A and a proper subset equivalent to A .

Observation: Set of natural numbers N is an infinite set.

Number of Elements of Finite Sets

Elements of finite set A is denoted by $n(A)$ and how to determine $n(A)$ is explained. Now, suppose $n(A) = p > 0$, $n(B) = q > 0$ where $A \cap B = \emptyset$.

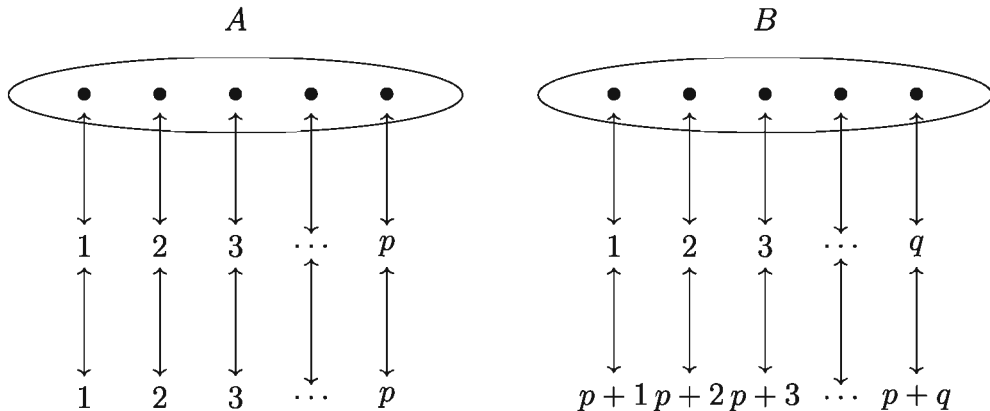

From the above mentioned one-one correspondence, we see that $A \cup B \sim J_{p+q}$.

So, $n(A \cup B) = p + q = n(A) + n(B)$. From this we can say the following proposition.

Proposition 8. If A and B are disjoint finite set to each other, then $n(A \cup B) = n(A) + n(B)$.

Expanding the proposition, we can say, $n(A \cup B \cup C) = n(A) + n(B) + n(C)$.

Similarly, $n(A \cup B \cup C \cup D) = n(A) + n(B) + n(C) + n(D)$ etc,

where A, B, C, D sets are disjoint finite set to one another.

Proposition 9. For any finite set A and B , $n(A \cup B) = n(A) + n(B) - n(A \cap B)$.

Proof: Here, $A \setminus B$, $A \cap B$ and $B \setminus A$ are disjoint sets to each other [See Venn Diagram].

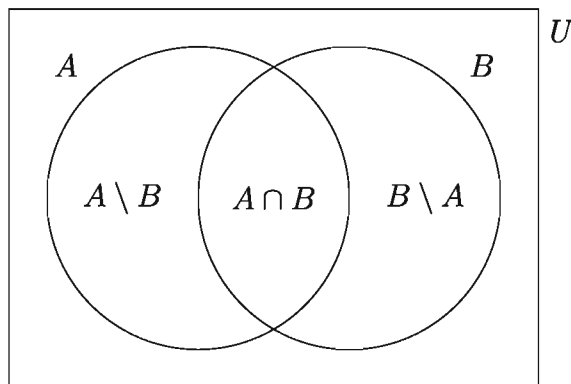

So, $A = (A \setminus B) \cup (A \cap B)$ and $B = (B \setminus A) \cup (A \cap B)$

Therefore, $A \cup B = (A \setminus B) \cup (A \cap B) \cup (B \setminus A)$

$$\therefore n(A) = n(A \setminus B) + n(A \cap B) \dots \dots (1)$$

$$\therefore n(B) = n(B \setminus A) + n(A \cap B) \dots \dots (2)$$

$$n(A \cup B) = n(A \setminus B) + n(A \cap B) + n(B \setminus A) \dots \dots (3)$$

So, from (1) we get, $n(A \setminus B) = n(A) - n(A \cap B)$

and from (2) we get, $n(B \setminus A) = n(B) - n(A \cap B)$

Now, putting $n(A \setminus B)$ and $n(B \setminus A)$ in (3), we get

$$n(A \cup B) = n(A) - n(A \cap B) + n(B) - n(A \cap B) + n(A \cap B)$$

$$\therefore n(A \cup B) = n(A) + n(B) - n(A \cap B)$$

Activity:

- In each of the following cases, describe all possible one-one correspondence between A and B:
 (1) $A = \{a, b\}$, $B = \{1, 2\}$ (2) $A = \{a, b, c\}$, $B = \{a, b, c\}$
- For each one-one correspondence described in the above question, describe the set $F = \{(x, y) : x \in A, y \in B\}$ and $x \leftrightarrow y$ in the tabular method.
- Suppose, $A = \{a, b, c, d\}$ and $B = \{1, 2, 3, 4\}$. Describe a subset F of $A \times B$ in such a way that associating the second component of each ordered pair in that subset with its first component yields a one-one correspondence between A and B where, $a \leftrightarrow 3$.
- Show that, sets $A = \{1, 2, 3, \dots, n\}$ and $B = \{1, 2, 2^2, \dots, 2^{n-1}\}$ are

equivalent.

- 5) Show that, set $S = \{3^n : n = 0 \text{ or } n \in \mathbb{N}\}$ is equivalent to \mathbb{N} .
- 6) Describe a proper subset of the S which is equivalent to S .
- 7) Show that, the set of all odd natural numbers $A = \{1, 3, 5, 7, \dots\}$ is an infinite set.

Set in Solving Real-Life Problems

Venn diagrams are used to solve real-life problems. Here it is noted that the elements of each set which will be written down in Venn diagram, is shown through some examples.

Example 15. Out of 50 persons, 35 can speak English, 25 can speak both English and Bangla and every one can speak at least one of these two languages. How many persons can speak Bangla? How many persons can speak only Bangla?

Solution: Let, S be the set of the 50 persons, E be the set of persons among them who can speak in English, B be the set of persons who can speak in Bangla.

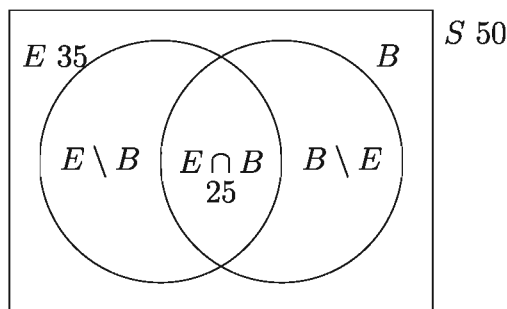

So according to the question, $n(S) = 50$, $n(E) = 35$, $n(E \cap B) = 25$ and $S = E \cup B$. Suppose, $n(B) = x$.

Then from, $n(S) = n(E \cup B) = n(E) + n(B) - n(E \cap B)$, we get

$$50 = 35 + x - 25 \text{ or, } x = 50 - 35 + 25 = 40 \text{ So, } n(B) = 40$$

\therefore 40 persons can speak in Bangla.

Now, the set of those who can speak in only Bangla is $(B \setminus E)$.

Let, $n(B \setminus E) = y$.

As the sets $E \cap B$ and $(B \setminus E)$ are disjoint and $B = (E \cap B) \cup (B \setminus E)$ [See Venn Diagram]

Therefore, $n(B) = n(E \cap B) + n(B \setminus E)$.

$\therefore 40 = 25 + y$ or, $y = 40 - 25 = 15$ So, $n(B \setminus E) = 15$

$\therefore 15$ persons can speak in only Bangla.

So, 40 persons can speak in Bangla and 15 persons can speak in only Bangla.

Example 16. Each of the 35 girls in a class likes at least one activity among running, swimming and dancing. Among them 15 girls like running, 4 like all three of swimming, running and dancing, 2 like just running, 7 like both running and swimming but not dancing. x like both swimming and dancing but not running, $2x$ like only dancing, while 2 girls like only swimming.

- 1) Show these information in a Venn Diagram.
- 2) Find x .
- 3) Express the set of the girls who like both running and dancing, but not swimming.
- 4) What is the number of girls who like both running and dancing but not swimming?

Solution:

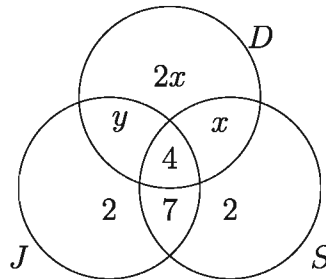

- 1) Suppose, set J = those who like running, S = those who like swimming, D = those who like dancing. Now let's look at the Venn Diagram shown above.
- 2) From the Venn Diagram $J' = \{\text{the girls who do not like running}\}$.
So, $n(J') = 35 - 15 = 20$ or, $2x + x + 2 = 20$ or, $3x = 18$ or $x = 6$.
- 3) Set of the girls who like both running and dancing but not swimming: $J \cap D \cap S'$.
- 4) $n(J \cap D \cap S') = y$ is shown in the Venn Diagram and given that $n(J) = 15$.

$$\therefore y + 4 + 7 + 2 = 15 \text{ or } y = 2.$$

Therefore, only 2 girls like running and dancing but not swimming.

Example 17. Out of 24 students, 18 like to play basketball, 12 like to play volleyball. Given that U = the set of the students, B = the set of students who like to play basketball, V = the set of students who like to play volleyball. Suppose, $n(B \cap V) = x$ and explain the data below in Venn diagram:

- 1) Describe the set $B \cup V$ and express $n(B \cup V)$ in terms of x .
- 2) Find the possible minimum value of x .
- 3) Find the possible maximum value of x .

Solution:

- 1) $B \cup V$ is the set of the students who like to play basketball or volleyball.

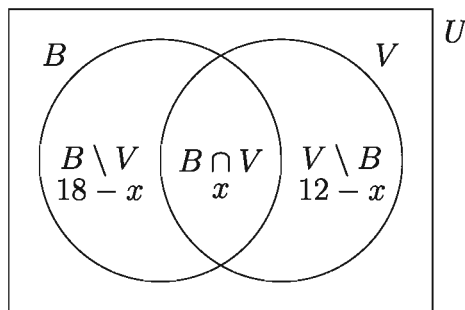

$$n(B \cup V) = (18 - x) + x + (12 - x) = 30 - x$$

- 2) x or $n(B \cap V)$ is the smallest, when $B \cup V = U$

$$\text{So, } n(B \cup V) = n(U) \text{ or } 30 - x = 24 \text{ or } x = 6$$

\therefore The possible minimum value of $x = 6$.

- 3) $n(B \cap V)$ is the largest when $V \subset B$

$$\text{Then, } n(B \cap V) = n(V) \text{ or } x = 12$$

\therefore Possible maximum value of $x = 12$.

Activity:

- 1) Out of 30 students of a class, 20 students like football and 15 like chess. Every student likes at least one of the two games. How many students like both of the games?

- 2) Among a certain number of persons, 50 can speak Bangla, 20 can speak English, and 10 can speak both Bangla and English. How many of these persons can speak at least one of the two languages?
- 3) Out of 100 students of the Institute of Modern Languages of the University of Dhaka, 42 have taken French, 30 have taken German, 28 have taken Spanish, 10 have taken both French and Spanish, 8 have taken both German and Spanish, 5 have taken both German and French, while 3 students have taken all three Languages.
- (1) How many students have taken none of the three languages?
- (2) How many students have taken just one of the three languages?
- (3) How many students have taken only two of the three languages?
- 4) Out of 50 students of class nine of the science section of a school, 29 have taken Biology, 24 have taken Higher Mathematics, 11 have taken both Biology and Higher Mathematics. How many students have taken neither Biology nor Higher Mathematics?

Exercises 1.1

1. (i) If any set has $2n$ elements, the number of its subsets will be 4^n .
- (ii) Set of all rational numbers $Q = \left\{ \frac{p}{q} : p, q \in Z \right\}$.
- (iii) $a, b \in R; (a, b) = \{x : x \in R \text{ and } a < x < b\}$.

Which combination of these statements is correct based on the information stated above?

- 1) i and ii 2) ii and iii 3) i and iii 4) i, ii and iii

If $A_n = \{n, 2n, 3n, \dots\}$ for every $n \in N$, answer the questions(2 - 4):

2. Which one of the following is the value of $A_1 \cap A_2$?
- 1) A_1 2) A_2 3) A_3 4) A_4
3. Which one of the following denotes the value of $A_3 \cap A_6$?
- 1) A_2 2) A_3 3) A_4 4) A_6
4. Which one of the following is to be written down instead of $A_2 \cap A_3$?

- 1) A_3 2) A_4 3) A_5 4) A_6

5. Given that, $U = \{x : 1 \leq x \leq 20, x \in Z\}$, $A = \{x : x \text{ is an odd number}\}$ and $B = \{x : x \text{ is a prime number}\}$. List the following sets in tabular method:

- 1) A 2) B
 3) $C = \{x : x \in A \text{ and } x \in B\}$ 4) $D = \{x : x \in A \text{ or } x \in B\}$

6. The number of elements of A and B are shown in the Venn Diagram below. If $n(A) = n(B)$, then find out the value of 1) x 2) $n(A \cup B)$ 3) $n(B \setminus A)$.

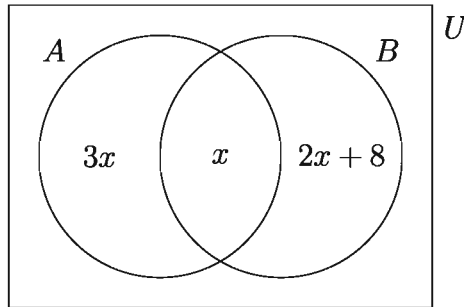

7. If $U = \{x : x \text{ is a positive integer}\}$, $A = \{x : x \geq 5\} \subset U$ and $B = \{x : 5x < 12\} \subset U$ then find the value of $n(A \cap B)$ and $n(A' \cup B)$.
8. If $U = \{x : x \text{ is an even integer}\}$, $A = \{x : 3x \geq 25\} \subset U$ and $B = \{x : 5x < 12\} \subset U$, then find $n(A \cap B)$ and $n(A' \cap B')$.
9. Show that, 1) $A \setminus A = \emptyset$, 2) $A \setminus (A \setminus A) = A$.
10. Show that, $A \times (B \cup C) = (A \times B) \cup (A \times C)$.
11. If $A \subset B$ and $C \subset D$, then show that, $(A \times C) \subset (B \times D)$.
12. Show that, sets $A = \{1, 2, 3, \dots, n\}$ and $B = \{1, 2, 2^2, \dots, 2^{n-1}\}$ are equivalent.
13. Show that, set of square of natural numbers $\{1, 4, 9, 16, 25, 36, \dots\}$ is an infinite set.
14. Prove that, if $n(A) = p$, $n(B) = q$ and $A \cap B = \emptyset$, then $n(A \cup B) = p + q$.
15. Prove that, if A, B, C are finite sets, $n(A \cup B \cup C) = n(A) + n(B) + n(C) - n(A \cap B) - n(B \cap C) - n(C \cap A) + n(A \cap B \cap C)$.
16. $A = \{a, b, x\}$ and $B = \{c, y\}$ are subsets of the universal set $U = \{a, b, c, x, y, z\}$,
- 1) Verify that, (i) $A \subset B'$ (ii) $A \cup B' = B'$ (iii) $A' \cap B = B$.

- 2) Find out: $(A \cap B) \cup (A \cap B')$.
17. Out of 30 students of a class, 19 have taken Economics, 17 have taken Geography, 11 have taken Civics, 12 have taken both Economics and Geography, 4 have taken both Civics and Geography, 7 have taken both Economics and Civics, while 3 have taken all three subjects. How many students have taken none of the three subjects?
18. In the following Venn Diagram, universal set $U = A \cup B \cup C$.

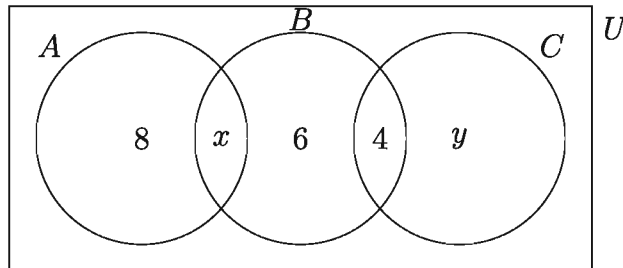

- 1) If $n(A \cap B) = n(B \cap C)$, then find the value of x .
 - 2) If $n(B \cap C') = n(A' \cap C)$, then find the value of y .
 - 3) Find the value of $n(U)$.
19. In the following Venn Diagram, $U = A \cup B \cup C$ and $n(U) = 50$.

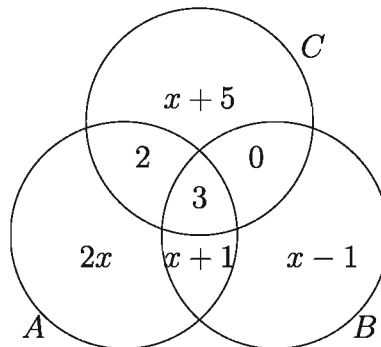

- 1) Find the value of x .
 - 2) Find the value of $n(B \cap C')$ and $n(A' \cap B)$.
 - 3) Find the value of $n(A \cap B \cap C')$
20. Three sets A , B and C are given in such a way that, $A \cap B = \emptyset$, $A \cap C = \emptyset$ and $C \subset B$. Describe the sets by drawing a Venn Diagram.

21. Given that, $A = \{x : 2 < x \leq 5, x \in R\}$, $B = \{x : 1 \leq x < 3, x \in R\}$ and $C = \{2, 4, 5\}$. Express the following sets in set builder method:
- 1) $A \cap B$
 - 2) $A' \cap B'$
 - 3) $A' \cup B$
22. Given that, $U = \{x : x < 10, x \in R\}$, $A = \{x : 1 < x \leq 4\}$ and $B = \{x : 3 \leq x < 6\}$. Express the following sets in set builder method:
- 1) $A \cap B$
 - 2) $A' \cap B$
 - 3) $A \cap B'$
 - 4) $A' \cap B'$
23. Sets A and B are given below for each case. Find $A \cup B$ and verify that $A \subset (A \cup B)$ and $B \subset (A \cup B)$.
- 1) $A = \{-2, -1, 0, 1, 2\}$ and $B = \{-3, 0, 3\}$
 - 2) $A = \{x : x \in N, x < 10 \text{ and } x \text{ is the multiple of } 2\}$ and $B = \{x : x \in N, x < 10 \text{ and } x \text{ is the multiple of } 3\}$
24. Find out $A \cap B$ in every case below and verify that, $(A \cap B) \subset A$ and $(A \cap B) \subset B$.
- 1) $A = \{0, 1, 2, 3\}$, $B = \{-1, 0, 2\}$
 - 2) $A = \{a, b, c, d\}$, $B = \{b, x, c, y\}$
25. Among the female students of Begum Rokeya College, a survey was conducted about their reading habits of the magazines the Bichitra, the Sandhani and the Purbani. It was found that 60% of the girls read the Bichitra, 50% read the Sandhani, 50% read the Pubani, 30% read the Bichitra and the Sandhani, 30% read the Bichitra and the Purbani, 20% read the Sandhani and the Purbani, while 10% read all three magazines.
- 1) What percentage of the girls do not read any of the three magazines?
 - 2) What percentage of the girls read just two of the above magazines?
26. $A = \{x : x \in R \text{ and } x^2 - (a + b)x + ab = 0\}$, $B = \{1, 2\}$ and $C = \{2, 4, 5\}$
- 1) Find out the elements of set A .
 - 2) Show that, $P(B \cap C) = P(B) \cap P(C)$.
 - 3) Prove that, $A \times (B \cup C) = (A \times B) \cup (A \times C)$.
27. Out of 100 students of a class, 42 students play football, 46 play cricket and 39 play chess. Among them 13 play football and cricket, 14 play cricket and chess and 12 play football and chess. Besides, 7 students are not expert in any of these games.
- 1) Show the set of students who are expert in the above three games and expert in none of the games in Venn diagram.

- 2) Find how many students are expert in all three games.
- 3) How many students are expert in at least one game? How many are expert in just two of the games?
28. Find out the set $P(\emptyset)$, $P(\{\emptyset\})$.
29. Once there was a mason in a village. He only built houses for those who did not construct their own house. Who built the house of the mason?
30. $A = \{x : x \notin A\}$. Describe briefly about the set A .

Function

Relation

We often consider different types of relations among the elements of set X or among the elements of set X and set Y . For example, greater-lesser relation in the set of natural numbers, brother-sister relation in a family, relation of age with your classmates in your recent birthday. For further information regarding this context, please refer to the Mathematics book of class 9-10.

Example 18. Suppose $A = \{0, 1, 2, 3\}$ is a set. The $x < y$ relation existing between the elements of the set A can be described by subset of $A \times A$ which is $S = \{(0, 1), (0, 2), (0, 3), (1, 2), (1, 3), (2, 3)\}$, where for ordered pairs included under S (first entry) $<$ (second entry). Here S is the $<$ relation described under A .

Example 19. Suppose, a is the father, b is the mother, c is the elder son, d is the younger son, e is the daughter, f is the wife of the elder son in a family. Assuming the set of members of the family as F , we get $F = \{a, b, c, d, e, f\}$. The brother relation in set F , which means the brother relation between x and y can be described by $B = \{(c, d), (c, e), (d, c), (d, e)\}$, where the first entry of the ordered pairs under set B is the brother of the second entry of the same ordered pair. The set B denotes the brother relation of set F .

Definition 4 (Relation). If two sets are X and Y , any subset of their cartesian product set $X \times Y$ is called **relation** from X to Y . So, $R \subseteq X \times Y$ is a relation from X to Y .

Activity: Describe the relation "x is the square of y" in a set Z in the form of set of ordered pairs.

Function

The idea of function is as important as sets in mathematics. In practical need, relations between two variables or two sets are considered.

Example 20. Relation between the radius and circumference of a circle is expressed as $p = 2\pi r$ where variables r and p denote the radius and the circumference of the circle respectively. Here for every possible value of r , one and only one value of p is definite. We say that, variable p is a function of variable r which is written as $p = f(r)$, $f(r) = 2\pi r$. In this functional relation the function has been assumed to be defined with values of r taken from set X and values of p from set Y . This function treated as relating X to Y $\{(r, p) : r \in X \text{ and } p \in Y, p = 2\pi r\}$. The idea of relations has been explained in the Mathematics book of class 9-10.

Definition 5 (Function). If X and Y are sets and under any rule, every element of set X is associated with one and only one element of set Y , that rule is called a **function** described from X to Y . These types of functions are indicated with symbols such as f, g, F, G etc.

Definition 6 (Domain and Codomain). If f is a function from set X to set Y , then this is expressed as $f : X \rightarrow Y$. X set is called **domain** of function $f : X \rightarrow Y$, while set Y is called **codomain**.

Definition 7 (Image and Preimage). If under function $f : X \rightarrow Y$, $x \in X$ is associated with $y \in Y$, then y is called **image** of x and x is called **preimage** of y under this function and it is expressed as $y = f(x)$.

Definition 8 (Range). Under function $f : X \rightarrow Y$, the set of the elements of Y which are the images of any element of X is regarded as **range** of function f and it is expressed as "range f ". So, $\text{range } f = \{y : y = f(x) \text{ where } x \in X\} = \{f(x) : x \in X\}$. To be noted that range f is the subset of codomain Y .

Function can be described in different ways. Let's take a look at the following examples.

Example 21. $f : x \rightarrow 2x + 1, x \in Z$; describes a function from the set of integers Z to Z . Under this function image of x is $y = f(x) = 2x + 1$;

the domain of the function, domain $f = Z$ and range of the function, range $f = \{y : y = 2x + 1, x \in Z\}$ is the set of all odd integers.

Example 22. A set of ordered pairs $F = \{(0, 0), (1, 1), (-1, 1), (2, 4), (-2, 4), (3, 9), (-3, 9)\}$ describes a function, whose domain is a set of first entries of the ordered pairs under F and range is set of second entries of the ordered pairs under F .

So, domain $F = \{0, 1, -1, 2, -2, 3, -3\}$ and range $F = \{0, 1, 4, 9\}$

If you look closely you will see in this case that under $F, x \in \text{dom of } F, F(x) = x^2$. To be noted that, set of an ordered pair will only define a function when first entries of different ordered pairs will be different.

Example 23. Considering the domain and range of the function F described below as A and B respectively, the function can be described with a diagram, where one and only one arrow sign started from every point of set A and ends at one and only one point of set B (left sided diagram). To be noted that, a set Y can be regarded as the codomain of the function, whose subset can be drawn with B (right sided diagram).

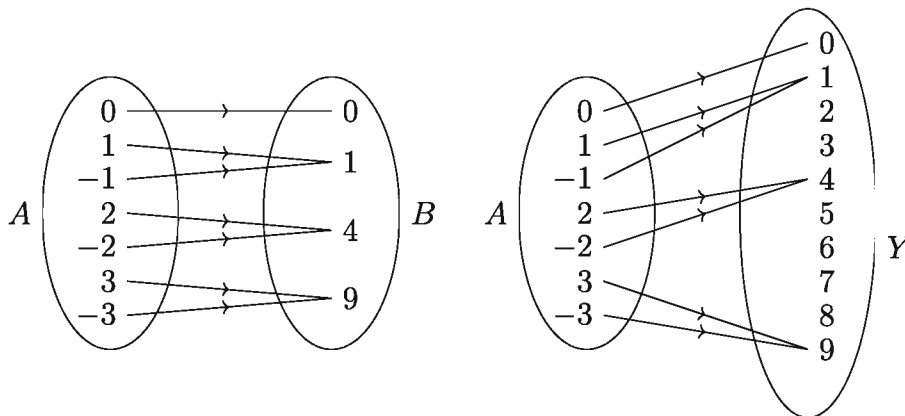

Inverse Function

Three functions are described below in the following three diagrams.

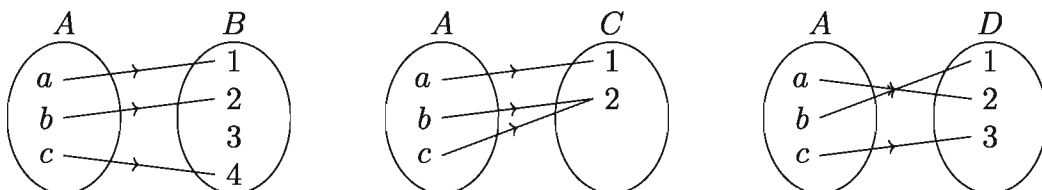

- 1) Under the left sided diagram drawn above, $a \rightarrow 1, b \rightarrow 2, c \rightarrow 4$. This function is one-one but not onto since there exists no preimage of 3.
- 2) Under the diagram drawn in the middle above, $a \rightarrow 1, b \rightarrow 2, c \rightarrow 2$. This function is onto but not one-one since 2 is the image of b and c .
- 3) Under the right sided diagram drawn above $a \rightarrow 2, b \rightarrow 1, c \rightarrow 3$. This function is one-on and onto. In the last case, for every element of codomain D , domain A has one and only one element which is definite. As a result, a function is described from D to A , which is called the inverse function of given function.

Definition 9 (Inverse Function). Suppose, $f : A \rightarrow B$ is a one-one and onto function. If a function $g : B \rightarrow A$ is described where for every $b \in B$, $g(b) = a$ if and only if $f(a) = b$, that function g is defined as the **inverse function** of f . This is indicated as f^{-1} so, $g = f^{-1}$.

If the function is f in the right-sided diagram drawn above, $f^{-1} : D \rightarrow A$ and $f^{-1}(1) = b, f^{-1}(2) = a, f^{-1}(3) = c$. However, in case of the other two diagrams, an inverse function is not possible.

Example 24. Suppose, $A = \{2, 3, 5, 7\}$ and $B = \{1, 2, 4, 7, 10\}$. Those elements of B which are divisible by the elements of A are shown below by drawing a diagram using arrow signs:

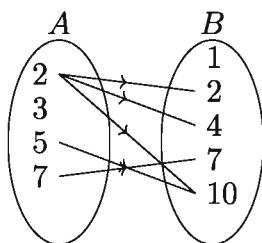

Here we now form the set $D = \{(2, 2), (2, 4), (2, 10), (5, 10), (7, 7)\}$ of all ordered pairs which describe the relation of divisibility. In the set D , the first entries of the included ordered pairs belongs to A while the second entries belong to B and are divisible by the first entries. So, $D \subset A \times B$ and $D = \{(x, y) : x \in A, y \in B \text{ and } y \text{ is divisible by } x\}$, Here the set D is a relation from set A to set B .

Example 25. Let's consider the set of ordered pairs of real numbers $L = \{(x, y) : x \in R, y \in R \text{ and } x < y\}$. $a < b$ for two real numbers a, b if and only if it is $(a, b) \in L$. Therefore, the set L describes the relation of lesser or greater.

Example 26. Which one of the following relations is not a function? Give reasons.

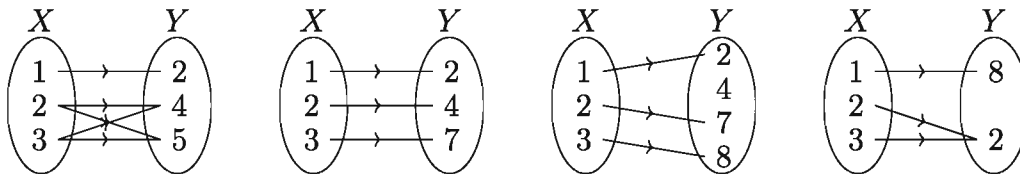

Solution: The relation shown in upper left is not a function because $2 \rightarrow 4$, $2 \rightarrow 5$ and $3 \rightarrow 4$, $3 \rightarrow 5$. On the other hand, all other three relations are functions.

Example 27. Find the range of the function $f : x \rightarrow 2x^2 + 1$ where the domain is $X = \{1, 2, 3\}$.

Solution: $f(x) = 2x^2 + 1$ where $x \in X$.

$$f(1) = 2(1)^2 + 1 = 3, f(2) = 2(2)^2 + 1 = 9 \text{ and } f(3) = 2(3)^2 + 1 = 19.$$

\therefore range set of $\{1, 2, 3\} = \{3, 9, 19\}$.

Example 28. For the function $f : x \rightarrow mx + c$, the images of 2 and 4 are respectively 7 and -1 . So find out:

- 1) The values of m and c .
- 2) The image of 5 under f .
- 3) The preimage of 3 under f .

Solution:

- 1) According to $f(x) = mx + c$,

$$f : 2 \rightarrow 7 \text{ So, } f(2) = 7 \text{ or, } 2m + c = 7 \dots\dots\dots (1)$$

$$f : 4 \rightarrow -1 \text{ So, } f(4) = -1 \text{ or, } 4m + c = -1 \dots\dots\dots (2)$$

From (1) and (2) we get $m = -4$ and $c = 15$

- 2) Under f , image of 5 is $f(5) = -4 \times 5 + 15 = -5$
- 3) If x is the preimage of 3, then $f(x) = 3$ So, $-4x + 15 = 3$ or $x = 3$

Activity: Is the relation $F = \{(-2, 4), (-1, 1), (0, 0), (1, 1), (2, 4)\}$ a function? Find its domain and range. If possible, find out a formula that defines F .

Remarks: A function F can be determined if its domain is defined and its image is uniquely specified for each element x of the domain. Sometimes the domain is kept implied. In such cases we take that specific set as domain, whose $F(x)$ remains fixed for its each element.

Example 29. Find the domain of the function $F(x) = \sqrt{1-x}$. Find whichever is defined among $F(-3)$, $F(0)$, $F\left(\frac{1}{2}\right)$, $F(1)$, $F(2)$.

Solution: $F(x) = \sqrt{1-x} \in R$ if and only if $1-x \geq 0$ or $1 \geq x$ Therefore, $x \leq 1$

So, Dom. $F = \{x : x \in R \text{ and } x \leq 1\}$

Here $F(-3) = \sqrt{1-(-3)} = \sqrt{4} = 2$

$$F(0) = \sqrt{1-0} = \sqrt{1} = 1$$

$$F\left(\frac{1}{2}\right) = \sqrt{1-\frac{1}{2}} = \sqrt{\frac{1}{2}} = \frac{1}{\sqrt{2}}$$

$$F(1) = \sqrt{1-1} = 0$$

$F(2)$ undefined, because $2 \notin \text{Dom. } F$.

Activity:

- 1) Which one of the following relations is not function? Give reasons.

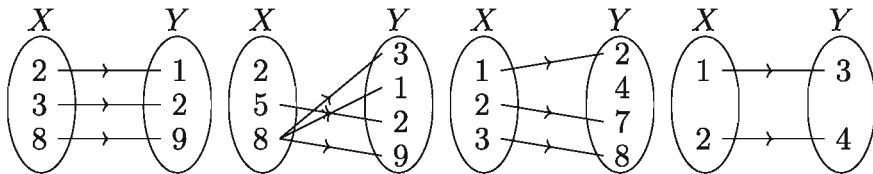

- 2) $f : x \rightarrow 4x + 2$ describes a function whose domain $D = \{-1, 3, 5\}$. Find its range set.

- 3) Describe the given relation S in tabular method and find which of these are function. Find dom S and range S , where $A = \{-2, -1, 0, 1, 2\}$.

(1) $S = \{(x, y) : x \in A, y \in A \text{ and } x + y = 1\}$

(2) $S = \{(x, y) : x \in A, y \in A \text{ and } x - y = 1\}$

(3) $S = \{(x, y) : x \in A, y \in A \text{ and } y = x^2\}$

(4) $S = \{(x, y) : x \in A, y \in A \text{ and } y^2 = x\}$

- 4) For the function defined by $F(x) = 2x - 1$,
- (1) Find $F(-2)$, $F(0)$, and $F(2)$.
 - (2) Find $F\left(\frac{a+1}{2}\right)$, where $a \in R$.
 - (3) If $F(x) = 5$, find x .
 - (4) Find x if $F(x) = y$, where $y \in R$.

One-One Function

The images of different elements under the function f in the Venn diagram below are always different.

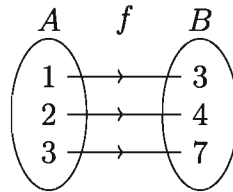

Definition 10 (One-One Function). A function f is called **one-one function** if images of the elements in its domain always are distinct under that function.

So, if

$$x_1, x_2 \in \text{dom } f \text{ and } x_1 \neq x_2 \text{ then } f(x_1) \neq f(x_2).$$

From the above definition we see that, a function $f : A \rightarrow B$ is called one-one function, if and only if $f(x_1) = f(x_2)$ then $x_1 = x_2$, where $x_1, x_2 \in A$.

Example 30. Is the function $f(x) = 3x + 5$, $x \in R$ a one-one function?

Solution: Let, $a, b \in R$ and $f(a) = f(b)$.

$$\text{So } 3a + 5 = 3b + 5 \text{ or, } 3a = 3b \text{ or, } a = b.$$

So function f is one-one.

Example 31. Show that the function, $F : R \rightarrow R$, $F(x) = x^2$ is not one-one.

Solution: Taking $x_1 = -1, x_2 = 1$ we see that, $x_1 \in \text{dom. } F, x_2 \in \text{dom. } F$ and $x_1 \neq x_2$.

$$\text{But } F(x_1) = F(-1) = (-1)^2 = 1, F(x_2) = F(1) = (1)^2 = 1.$$

So, $F(x_1) = F(x_2), \therefore F$ is not one-one.

Observation: Inverse relation of a function may not be a function.

Example 32. Find out for the function $f(x) = \frac{x}{x-2}$, $x \neq 2$:

1) $f(5)$

2) $f^{-1}(2)$

Solution:

1) $f(x) = \frac{x}{x-2}, x \neq 2$

$$\therefore f(5) = \frac{5}{5-2} = \frac{5}{3} = 1\frac{2}{3}$$

2) Let, $a = f^{-1}(2)$ So $f(a) = 2$

$$\implies \frac{a}{a-2} = 2 \implies a = 2a - 4 \implies a = 4$$

$$\therefore f^{-1}(2) = 4$$

Example 33. $f(x) = 3x + 1$, $0 \leq x \leq 2$

1) Determine the range of f

2) Show that f is a one-one function.

3) Determine f^{-1} and draw the graph of f and f^{-1} .

Solution:

1) From $f(x) = 3x + 1$, $0 \leq x \leq 2$ we get the vertices $(0, 1)$ and $(2, 7)$

$$\therefore \text{Range } f : R = \{y : 1 \leq y \leq 7\}$$

2) Since for every $y \in R$, only the image y of $x \in \{0 \leq x \leq 2\}$ is shown, so f is a one-one function.

3) Let, $y = f(x)$, is the image of x .

$$\text{So, } y = 3x + 1 \implies x = \frac{1}{3}(y - 1)$$

$$\text{Inverse function } f^{-1} : y \rightarrow x \text{ where, } x = \frac{1}{3}(y - 1)$$

or, $f^{-1} : y \rightarrow \frac{1}{3}(y - 1)$ which is shown in the diagram.

$$\text{Replacing } x \text{ in the place of } y, f^{-1} : x \rightarrow \frac{1}{3}(x - 1)$$

Drawn line of f^{-1} where $y = \frac{1}{3}(x - 1)$, $1 \leq x \leq 7$ is shown.

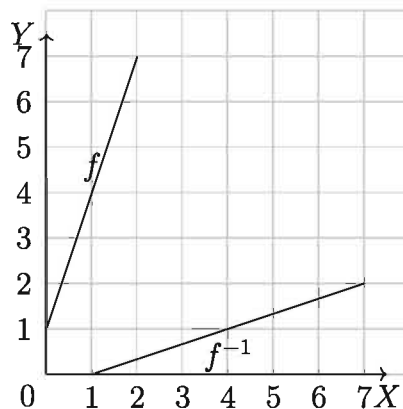

Onto Function

In the diagram we consider the sets $A = \{1, 2, 3\}$ and $B = \{5, 7, 9\}$ under the function f where $1 \rightarrow 5$, $2 \rightarrow 7$ and $3 \rightarrow 9$. So, every element of B is an image of an element of set A . This type of function is called **onto function**.

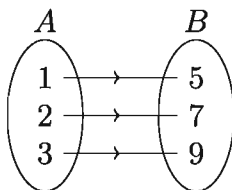

Definition 11 (Onto Function). A function $f : A \rightarrow B$ will be called the **onto function** if for every $b \in B$, there exists $a \in A$ such that $f(a) = b$. So, $B = \text{range } f$.

Example 34. If two functions $f : R \rightarrow R$ and $g : R \rightarrow R$ are defined by $f(x) = x + 5$ and $g(x) = x - 5$ respectively, then show that, f is an inverse function of g .

Solution: The function f is one-one, since

$$\text{If } f(x_1) = f(x_2), \text{ then } x_1 + 5 = x_2 + 5 \text{ or, } x_1 = x_2.$$

Again, function f is onto, since

$$\text{If } y = f(x) \text{ then } x + 5 = y \text{ or, } x = y - 5 \in R.$$

So, there is an inverse function f^{-1} .

$$\text{If } f^{-1}(x) = y \text{ then } f(y) = x \text{ or, } y + 5 = x \text{ or, } y = x - 5$$

$$\text{Again, } f^{-1}(x) = x - 5 = g(x)$$

As domains of both f^{-1} and g are same, $f^{-1} = g$

Activity:

1) For each one-one function below, find the related f^{-1} if there is any

$$(1) f(x) = \frac{3}{x-1}, x \neq 1$$

$$(2) f(x) = \frac{2x}{x-2}, x \neq 2$$

$$(3) f : x \rightarrow \frac{2x+3}{2x-1}, x \neq \frac{1}{2}$$

2) If there is f^{-1} in case of the function $f(x) = \frac{4x-9}{x-2}, x \neq 2$, then

(1) Find $f^{-1}(-1)$ and $f^{-1}(1)$.

- (2) Find the value of x such that $4f^{-1}(x) = x$
- 3) If there is f^{-1} for the function $f(x) = \frac{2x+2}{x-1}$, $x \neq 1$, then
- (1) Find $f^{-1}(3)$.
- (2) If $f^{-1}(p) = kp$, express k in terms of p .
- 4) Ascertain whether each given relation F below is a function. If F is a function then find its domain and range, and ascertain whether it is one-one:
- (1) $F = \{(x, y) \in R^2 : y = x\}$ (2) $F = \{(x, y) \in R^2 : y = x^2\}$
- (3) $F = \{(x, y) \in R^2 : y^2 = x\}$ (4) $F = \{(x, y) \in R^2 : y = \sqrt{x}\}$
- 5) If the function $f : \{-2, -1, 0, 1, 2\} \rightarrow \{-8, -1, 0, 1, 8\}$ is defined by $f(x) = x^3$ then show that, f is one-one and onto.
- 6) $f : \{1, 2, 3, 4\} \rightarrow R$ is a function which is defined by $f(x) = 2x + 1$. Show that, f is a one-one function but not an onto function.

Graphs of Relations and Functions

Graphs are useful geometrical presentations of functions. To draw the graph of $y = f(x)$, we draw a pair of perpendicular bisectors XOX' and YOY' through a point O . O is called the **origin**, XOX' is called the **x-axis** while YOY' is called the **y-axis**.

For drawing the graph of $y = f(x)$, pairs of values of independent variable x and dependent variable y need to be tabulated between an interval $a \leq x \leq b$. Then the limited amount of points of the tabulation are placed on the plane xy . By joining the obtained points with a straight line or a curved line, we can get the graph of function $y = f(x)$. In the Mathematics book of class 9-10, the initial concepts about graphs have been imparted. Here, the linear function, the quadratic function and the construction of the graphs of the circle have been discussed.

Linear Functions

The general form of linear function is $f(x) = mx + b$ where, m and b are real numbers. The graph of this function is a line whose slope is m and the intercept of y axis is b .

Here, let $m = 3$ and $b = 2$ So, we can have the function $f(x) = 3x + 2$

From the described function, we get following related values of x and y :

x	-2	-1	0	1	2
y	-4	-1	2	5	8

\therefore The graph of the function is shown aside.

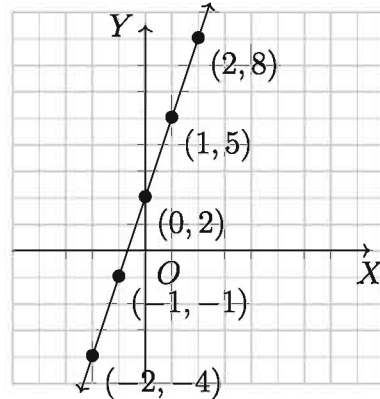

Quadratic Function

A quadratic function is a function which can be described by the equation $y = ax^2 + bx + c$ where a , b and c are real numbers and $a \neq 0$. Suppose, in this function $a = 1$, $b = -4$, $c = -1$. So $y = ax^2 + bx + c$ can be written as $y = x^2 - 4x - 1$. We can get the related values of x and y from the described function which is shown in the following table.

x	$x^2 - 4x - 1$	y
-1	$(-1)^2 - 4(-1) - 1$	4
0	$(0)^2 - 4(0) - 1$	-1
1	$(1)^2 - 4(1) - 1$	-4
2	$(2)^2 - 4(2) - 1$	-5
3	$(3)^2 - 4(3) - 1$	-4
4	$(4)^2 - 4(4) - 1$	-1
5	$(5)^2 - 4(5) - 1$	4

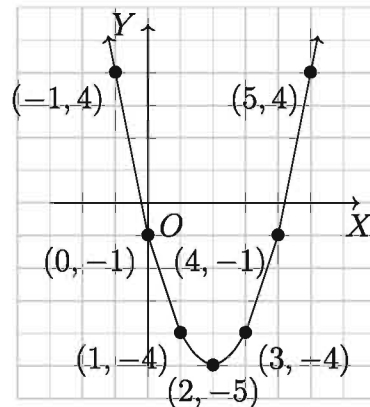

This is the required graph of the quadratic function. Let's observe some general properties of this quadratic function.

- 1) The graph is paraboloid shaped.
- 2) Symmetric point may be found about y axis or parallel to the y axis.
- 3) The value of the function will be maximum or minimum at a certain point.

Graph of a Circle

Noted that p , q and r are constants and if $r \neq 0$ then in R , the graph of a relation $S = \{(x, y) : (x - p)^2 + (y - q)^2 = r^2\}$ is a circle whose centre is the point (p, q) and radius is r (see the Mathematics book of class 9-10). In the graph paper, by plotting the point (p, q) as centre and taking r as radius we can draw a circle which will make the graph.

Remark: If the solution set of a relation is infinite, the known system of drawing its graph is to plot sufficient numbers of representative points of solution in the graph paper and then to join them, so that the graph of the relation can be clear. But if the graph of relation is a circle, using compass will make the work easier and beautiful, so we use the latter means.

Example 35. $S = \{(x, y) : x^2 + y^2 = 16\}$

Therefore, the graph of S is a circle $x^2 + y^2 = 4^2$, with centre $(0, 0)$ and radius $r = 4$.

Graph of S is shown below:

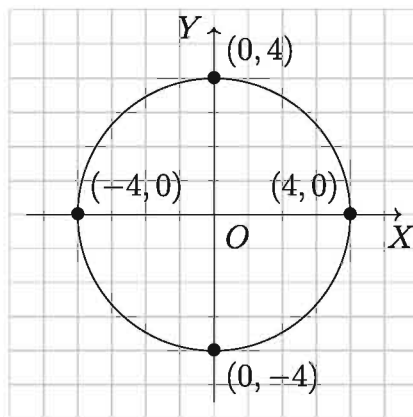

Activity:

1) In the following cases, express y as a function of x from the given equations.

(1) $y - 2 = 3(x - 5)$

(2) $y - 5 = -2(x + 1)$

(3) $y - 2 = \frac{1}{2}(x + 3)$

(4) $y - 5 = \frac{4}{3}(x - 3)$

2) Draw the graphs:

(1) $y = 3x - 1$

(2) $x + y = 3$

(3) $x^2 + y^2 = 9$

(4) $y = \frac{1}{3}x + 1$

Example 36. Given that $f : x \rightarrow \frac{2x - 1}{2x + 3}$.

- 1) $f\left(-\frac{1}{3}\right) = ?$
- 2) Determine whether the function is one-one.
- 3) If $2f^{-1}(x) = x$, find the value of x .

Solution:

- 1) Given that, $f : x \rightarrow \frac{2x - 1}{2x + 3}$. Therefore, $f(x) = \frac{2x - 1}{2x + 3}$

$$f\left(-\frac{1}{3}\right) = \frac{2\left(-\frac{1}{3}\right) - 1}{2\left(-\frac{1}{3}\right) + 3} = \frac{-\frac{2}{3} - 1}{-\frac{2}{3} + 3} = \frac{-\frac{5}{3}}{\frac{7}{3}} = -\frac{5}{3} \cdot \frac{3}{7} = -\frac{5}{7}$$

- 2) Since, $f : x \rightarrow \frac{2x - 1}{2x + 3}$, $f(x) = \frac{2x - 1}{2x + 3}$

Here, if $2x + 3 = 0$ then $x = -\frac{3}{2}$, and therefore the function becomes undefined.

$$\therefore x \neq -\frac{3}{2}, \text{ So } \text{dom } f = R \setminus \left\{-\frac{3}{2}\right\}$$

Let, $x_1 \in \text{dom. } f$ and $x_2 \in \text{dom } f$

$$\therefore f(x_1) = \frac{2x_1 - 1}{2x_1 + 3} \text{ and } f(x_2) = \frac{2x_2 - 1}{2x_2 + 3}$$

Now, $f(x_1) = f(x_2)$ will happen, if and only if

$$\frac{2x_1 - 1}{2x_1 + 3} = \frac{2x_2 - 1}{2x_2 + 3} \quad \text{or, } \frac{2x_1 - 1}{2x_1 + 3} - 1 = \frac{2x_2 - 1}{2x_2 + 3} - 1$$

$$\text{or, } \frac{2x_1 - 1 - 2x_1 - 3}{2x_1 + 3} = \frac{2x_2 - 1 - 2x_2 - 3}{2x_2 + 3}$$

$$\text{or, } \frac{-4}{2x_1 + 3} = \frac{-4}{2x_2 + 3} \quad \text{or, } 2x_1 + 3 = 2x_2 + 3$$

$$\text{or, } 2x_1 = 2x_2 \quad \text{or } x_1 = x_2$$

\therefore The function is one-one.

- 3) Given that, $f : x \rightarrow \frac{2x - 1}{2x + 3}$, So $f(x) = \frac{2x - 1}{2x + 3}$

$$\text{Let, } f(x) = y \quad \therefore x = f^{-1}(y)$$

$$\begin{aligned} \text{Now, } f(x) &= \frac{2x-1}{2x+3} & \text{or, } y &= \frac{2x-1}{2x+3} \\ \text{or, } 2xy + 3y &= 2x-1 & \text{or, } 2xy - 2x &= -3y-1 \\ \text{or, } -2x(1-y) &= -(1+3y) \\ \text{or, } x &= \frac{1+3y}{2(1-y)} \\ \text{or, } f^{-1}(y) &= \frac{1+3y}{2(1-y)} \quad [\because x = f^{-1}(y)] \\ \text{or, } f^{-1}(x) &= \frac{1+3x}{2(1-x)} \quad [\text{changing the variable}] \\ \text{or, } 2f^{-1}(x) &= \frac{1+3x}{1-x} \\ \text{or, } x &= \frac{1+3x}{1-x} \quad [\because 2f^{-1}(x) = x] \\ \text{or, } 1+3x &= x-x^2 & \text{or, } x^2+3x-x+1 &= 0 \\ \text{or, } x^2+2x+1 &= 0 & \text{or, } (x+1)^2 &= 0 \\ \text{or, } x+1 &= 0 & \text{or, } x &= -1 \\ \therefore \text{Determined value } x &= -1 \end{aligned}$$

Exercises 1.2

- Which one is the domain of the relation $\{(2, 2), (4, 2), (2, 10), (7, 7)\}$?
 - $\{2, 4, 5, 7\}$
 - $\{2, 2, 10, 7\}$
 - $\{2, 4, 10, 7\}$
 - $\{2, 4, 7\}$
- Given, $S = \{(x, y) : x \in A, y \in A \text{ and } y = x^2\}$ and $A = \{-2, -1, 0, 1, 2\}$ which of the following is a member of the relation S ?
 - $(2, 4)$
 - $(-2, 4)$
 - $(-1, 1)$
 - $(1, -1)$
- If $S = \{(1, 4), (2, 1), (3, 0), (4, 1), (5, 4)\}$ then,
 - The range of the relation S is $\{4, 1, 0\}$
 - The inverse relation of S is, $S^{-1} = \{(4, 1), (1, 2), (0, 3), (1, 4), (4, 5)\}$
 - The relation S is a function

Which combination of these statements is correct?

- 1) i and ii 2) ii and iii 3) i and iii 4) i , ii and iii
4. If $F(x) = \sqrt{x-1}$, then $F(10) = ?$
 1) 9 2) 3 3) -3 4) $\sqrt{10}$
5. If $S = \{(x, y) : x^2 + y^2 - 25 = 0 \text{ and } x \geq 0\}$,
- (i) The relation is not a function.
 (ii) The graph of the relation is a half-circle.
 (iii) The graph of the relation will be on upper half plane of the x axis.

Which one of the following is true?

- 1) i , ii 2) i , iii 3) ii , iii 4) i , ii and iii
6. If $F(x) = \sqrt{x-1} = 2$, what is the value of x ?
 1) 5 2) 24 3) 25 4) 26
7. Which one below is the domain of the function $F(x) = \sqrt{x-1}$?
 1) Dom. $F = \{x \in R : x \neq 1\}$ 2) Dom. $F = \{x \in R : x \geq 1\}$
 3) Dom. $F = \{x \in R : x \leq 1\}$ 4) Dom. $F = \{x \in R : x > 1\}$
8. (i) Find the domain, range and inverse relation of the given relation S .
 (ii) Ascertain whether relations S or S^{-1} are functions.
 (iii) Are the functions among these relations one-one?
 1) $S = \{(1, 5), (2, 10), (3, 15), (4, 20)\}$
 2) $S = \{(-3, 8), (-2, 3), (-1, 0), (0, -1), (1, 0), (2, 3), (3, 8)\}$
 3) $S = \left\{ \left(\frac{1}{2}, 0 \right), (1, 1), (1, -1), \left(\frac{5}{2}, 2 \right), \left(\frac{5}{2}, -2 \right) \right\}$
 4) $S = \{(-3, -3), (-1, -1), (0, 0), (1, 1), (3, 3)\}$
 5) $S = \{(2, 1), (2, 2), (2, 3)\}$
9. For the described function $F(x) = \sqrt{x-1}$,
- 1) Find $F(1)$, $F(5)$ and $F(10)$.
 2) Find $F(a^2 + 1)$ where $a \in R$.
 3) If $F(x) = 5$, find x .
 4) If $F(x) = y$, find x where $y \geq 0$.

10. For the function $F : R \rightarrow R$, $F(x) = x^3$,
- 1) Find dom. F and range F .
 - 2) Show that F is a one-one function.
 - 3) Find F^{-1} .
 - 4) Show that F^{-1} is a function.
11. 1) If $f : R \rightarrow R$ is a function which is defined by $f(x) = ax + b$; $a, b \in R$, $a \neq 0$; show that f is one-one and onto.
- 2) If $f : [0, 1] \rightarrow [0, 1]$ is a function which is defined by $f(x) = \sqrt{1 - x^2}$, show that f is one-one and onto.
12. 1) If functions $f : R \rightarrow R$ and $g : R \rightarrow R$ are defined by $f(x) = x^3 + 5$ and $g(x) = (x - 5)^{\frac{1}{3}}$ then show that, $g = f^{-1}$.
- 2) If function $f : R \rightarrow R$ is defined by $f(x) = 5x - 4$, then, find $y = f^{-1}(x)$.
13. Draw the graph of the relation S and determine from the graph whether the relation is a function.
- 1) $S = \{(x, y) : 2x - y + 5 = 0\}$
 - 2) $S = \{(x, y) : x + y = 1\}$
 - 3) $S = \{(x, y) : 3x + y = 4\}$
 - 4) $S = \{(x, y) : x = -2\}$
14. Draw the graph of the relation S and determine (from the graph) whether the relation is function.
- 1) $S = \{(x, y) : x^2 + y^2 = 25\}$
 - 2) $S = \{(x, y) : x^2 + y = 9\}$
15. Given that, $F(x) = 2x - 1$.
- 1) Find the values of $F(x + 1)$ and $F\left(\frac{1}{2}\right)$.
 - 2) Verify whether the function $F(x)$ is one-one, when $x, y \in R$.
 - 3) If $F(x) = y$, determine the values of y for three numerical values of x and draw the graph of the equation $y = 2x - 1$.

16. Two functions $f : R \rightarrow R$ and $g : R \rightarrow R$ are defined by $f(x) = 3x + 3$ and $g(x) = \frac{x-3}{3}$ respectively.
- 1) Find the value of $g^{-1}(-3)$.
 - 2) Determine whether $f(x)$ is an onto function.
 - 3) Show that, $g = f^{-1}$.
17. Given that, $f(x) = \sqrt{x-4}$.
- 1) Find the domain of $f(x)$.
 - 2) Determine whether $f(x)$ is a one-one function.
 - 3) Determine whether $f^{-1}(x)$ is a function with the help of graph.

Chapter 2

Algebraic Expression

We are familiar with various types of algebraic expressions. When one or more numbers and symbols representing numbers are combined meaningfully by one or more than one of $+$, $-$, \times , \div , power or rational sign, a new symbol representing numbers is created. It is called an **algebraic expression** or in brief **expression**. For example, each of $2x$, $2x + 3ay$, $6x + 4y^2 + a + \sqrt{z}$ etc, is an algebraic expression.

At the end of this chapter, students will be able to -

- ▶ explain the concept of a polynomial;
- ▶ explain with example the concept of a polynomial with one variable;
- ▶ explain multiplication and division of polynomials;
- ▶ explain the remainder theorem and the factor theorem and apply to factorize a polynomial;
- ▶ explain homogeneous expressions, symmetric expressions and cyclic expressions;
- ▶ factorize homogeneous expression, symmetric expressions and cyclic expression; and
- ▶ resolve rational fractions into partial fractions.

Variable, Constant and Polynomial

In any discussion, a literal symbol representing a number may be a variable or a constant. If such a symbol denotes any unscheduled element of the number set consisting of more than one elements we call the symbol a variable and the set is called the domains. If the symbol denotes a definite number, it is called a constant. In any discussion a variable can take any value from its domain, but the value of a constant remains fixed all through. A polynomial is a special type of algebraic expression. In a polynomial there are one or more terms and each

Forma-6, Higher Mathe, Class-9-10

term is a product of a constant and a non-negative integral power of one or more variables.

Polynomial of One Variable

Let, x be a variable. Then, (i) a , (ii) $ax+b$, (iii) ax^2+bx+c , (iv) ax^3+bx^2+cx+d ; expressions are polynomials of the variable x ; where a , b , c , d are fixed numbers constants. Generally, the terms of a polynomial of the variable x have the form Cx^p , where C (independent of x) is a fixed number (which may be zero) and p is a non-negative integer. If p is zero, the term becomes C , and if C is zero, the term is suppressed in the polynomial. C is called the **coefficient** of x^p in the term Cx^p and p is called the **degree** of the term. The largest of the degrees of the terms appearing in a polynomial is called the **degree of the polynomial**. The term having the largest degree is called the **leading term** and the coefficient of the term having the largest degree is called the **leading coefficient**; the term with degree 0, that is, the term independent of variable x , is called the **constant term**. For example, $2x^6 - 3x^5 - x^4 + 2x - 5$ is a polynomial of the variable x , its degree is 6, its leading term is $2x^6$ leading coefficient is 2 and constant is -5 . If $a \neq 0$, the aforesaid (i) degree of the polynomial is 0, (ii) degree of the polynomial is 1, (iii) degree of the polynomial is 2, and (iv) degree of polynomial is 3. Any non zero constant ($a \neq 0$) is a 0 degree polynomial of the variable (consider $a = ax^0$). The number 0 is considered a zero-polynomial and the degree of a zero-polynomial is considered undefined

A polynomial of the variable x is usually arranged in descending order of the degrees x of its terms (the leading term appearing first and the constant term appearing last). This arrangement of a polynomial is called its **standard form**. For convenience of using, polynomials of the variable x are denoted by symbols like $P(x)$, $Q(x)$ *et cetera*. For example, $P(x) = 2x^2 + 7x + 5$. Such symbol $P(x)$ indicates that the values of a polynomial depend on the values of x . If a specific number a is substituted for x in the polynomial, the value of the polynomial for that value of x is denoted by $P(a)$.

Example 1. if $P(x) = 3x^3 + 2x^2 - 7x + 8$, then find the value of $P(2)$, $P(-2)$, and $P\left(\frac{1}{2}\right)$.

Solution: Replacing x successively with 2, -2 , $\frac{1}{2}$, we get—

$$P(2) = 3(2^3) + 2(2^2) - 7(2) + 8 = 26$$

$$P(-2) = 3(-2)^3 + 2(-2)^2 - 7(-2) + 8 = 6$$

$$P\left(\frac{1}{2}\right) = 3\left(\frac{1}{2}\right)^3 + 2\left(\frac{1}{2}\right)^2 - 7\left(\frac{1}{2}\right) + 8 = \frac{43}{8}$$

Polynomials of Two Variables

The polynomials listed below are of the variables x and y .

$$2x + 3y - 1$$

$$x^2 - 4xy + y^2 - 5x + 7y + 1$$

$$8x^3 + y^3 + 10x^2y + 6xy^2 - 6x + 2$$

The terms of such polynomials have the form $Cx^p y^q$ where C is a definite number (constant) and p, q are non-negative integers. In the term $Cx^p y^q$, the coefficient of $x^p y^q$ is C and the degree of the term is $p + q$. In such polynomial, the mentioned largest of the degrees of the terms is called the degree of the polynomial. Such polynomials are denoted by $P(x, y)$. For example, the polynomial $P(x, y) = 8x^3 + y^3 - 4x^2 + 7xy + 2y - 5$ has degree 3 and $P(1, 0) = 8 - 4 - 5 = -1$.

Polynomial of Three Variables

The terms of a polynomial of the variable x, y and z have the form $Cx^p y^q z^r$ where C (constant) is the coefficient of the term and non-negative integers are p, q, r ; $p + q + r$ is the **degree of this term** and in the mentioned terms of the polynomial, the largest of the degrees is called the **degree of the polynomial**. Such polynomial is denoted by the symbol $P(x, y, z)$. For example, the polynomial $P(x, y, z) = x^3 + y^3 + z^3 - 3xyz$ has degree 3, and $P(1, 1, -2) = 1 + 1 - 8 + 6 = 0$.

Activity:

1) Determine the polynomial from below:

(1) $2x^3$

(2) $7 - 3a^2$

(3) $x^3 + x^{-2}$

(4) $\frac{a^2 + a}{a^3 - a}$

(5) $5x^2 - 2xy + 3y^2$

(6) $6a + 3b$

(7) $c^2 + \frac{2}{c} - 3$

(8) $3\sqrt[n]{n-4}$

(9) $2x(x^2 + 3y)$

(10) $3x - (2y + 4z)$

(11) $\frac{6}{x} + 2y$

(12) $\frac{3}{4}x - 2y$

2) Determine the variables and degrees from the polynomials listed below:

(1) $x^2 + 10x + 5$

(2) $3a + 2b$

(3) $4xyz$

$$(4) 2m^2n - mn^2 \quad (5) 7a + b - 2 \quad (6) 6a^2b^2c^2$$

3) Express each of the given polynomials–

(i) as a polynomial of the variable x in its standard form, and ascertain its degree, leading coefficient, and constant term;

(ii) as a polynomial of the variable y in its standard form, and ascertain its as a polynomial in y degree, leading coefficient and constant term.

$$(1) 3x^2 - y^2 + x - 3$$

$$(2) x^2 - x^6 + x^4 + 3$$

$$(3) 5x^2y - 4x^4y^4 - 2$$

$$(4) x + 2x^2 + 3x^3 + 6$$

$$(5) 3x^3y + 2xyz - x^4$$

4) if $P(x) = 2x^2 + 3$, then determine the value of $P(5)$, $P(6)$, $P\left(\frac{1}{2}\right)$.

Multiplication and Division of Polynomial

Addition, Subtraction and Multiplication of two polynomial is always polynomial, but division of polynomial may or may not be polynomial. For example, if we divide x by x^3 , take the answer as x^{-2} , then it is not a polynomial but if we take x as a remainder and result as 0, it is a polynomial.

Example 2. What is the result of the multiplication of $(x^2 + 2)$ and $(x + 1)$?

Here, the result of multiplication of $(x^2 + 2)$ and $(x + 1)$ is $(x^2 + 2)(x + 1) = x^3 + x^2 + 2x + 2$, which is a polynomial with a degree $2 + 1 = 3$ and leading co-efficient is $1 \times 1 = 1$

Example 3. What is the quotient when $(x^2 + 1)(x - 6)$ is divided by $2x^2 + 3$?

Here, Dividend $P(x) = (x^2 + 1)(x - 6) = x^3 - 6x^2 + x - 6$ with a degree 3 and leading co-efficient 1.

And Divisor $Q(x) = 2x^2 + 3$ with a degree 2 and leading co-efficient 2.

Dividing $P(x)$ by $Q(x)$, we get Quotient, $F(x) = \frac{1}{2}x - 3$, and Remainder, $R(x) = -\frac{x}{2} + 3$. Hence, Quotient, $F(x)$, is a polynomial with a degree $3 - 2 = 1$ and leading co-efficient $\frac{1}{2}$.

Note: The following rules hold true for multiplication and division of two polynomials.

- 1) Multiplication of polynomial of $P(x)$ and $Q(x)$ of variable x yields a polynomial. whose degree = Degree of $P(x)$ + Degree of $Q(x)$ leading co-efficient = Leading co-efficient of $P(x)$ × Leading Co-efficient of $Q(x)$
- 2) If we divide polynomial $P(x)$ by $Q(x)$ of variable x and the quotient $R(x) = \frac{P(x)}{Q(x)}$ is also a polynomial then, Degree of $R(x) = \text{Degree of } P(x) - \text{Degree of } Q(x)$ and Leading Co-efficient = $\frac{\text{leading co-efficient of } P(x)}{\text{leading co-efficient of } Q(x)}$

Division Algorithm

If both $P(x)$ and $Q(x)$ are the polynomials of the variable x and if degree of $Q(x) \leq$ degree of $P(x)$, we can divide $P(x)$ by $Q(x)$ in usual manner and we obtain a quotient $F(x)$ and a remainder $R(x)$, where,

- 1) Both $F(x)$ and $R(x)$ are the polynomial of the variable x
- 2) degree of $F(x) = \text{degree of } P(x) - \text{degree of } Q(x)$
- 3) either $R(x) = 0$ or degree of $R(x) < \text{degree of } Q(x)$
- 4) $P(x) = F(x)Q(x) + R(x)$ holds for all x .

Equality Rule of Polynomials

- 1) If $ax + b = px + q$ holds for all x , putting $x = 0$ and $x = 1$ we get respectively, $b = q$ and $a + b = p + q$, from whence it is found $a = p$, $b = q$
- 2) If $ax^2 + bx + c = px^2 + qx + r$ holds for x , putting $x = 0$, $x = 1$ and $x = -1$ we get respectively $c = r$, $a + b + c = p + q + r$ and $a - b + c = p - q + r$ from whence it is found that $a = p$, $b = q$, $c = r$.
- 3) In general, if $a_0x^n + a_1x^{n-1} + a_2x^{n-2} + \dots + a_{n-1}x + a_n = p_0x^n + p_1x^{n-1} + p_2x^{n-2} + \dots + p_{n-1}x + p_n$ holds for all x , $a_0 = p_0$, $a_1 = p_1, \dots$, $a_{n-1} = p_{n-1}$, $a_n = p_n$.

i.e., the two coefficients of x with the same power are equal in both sides of an equal sign.

Remarks: It is convenient to denote the coefficients of a polynomial of degree n by a_0 (a sub-zero), a_1 (a sub - one) etc.

Identity

If the two polynomials $P(x)$, $Q(x)$ for all x are equal, their equality is called the

referred to as identity of the polynomials; sometimes this is indicated by writing $P(x) \equiv Q(x)$. In this case the two polynomials $P(x)$ and $Q(x)$ are the same. The sign \equiv is called the identity sign. Generally, the equality of the two algebraic expressions is called the **identity**, if the domain of any variable of the two expressions is the same and for the values included in the domain of the variables, the values of the two expressions are equal. For example, $x(x + 2) = x^2 + 2x$, $(x + y)^2 = x^2 + 2xy + y^2$ are identities.

Remainder and Factor Theorems

In this section we shall deal with polynomials of one variable only. First, we consider the two examples.

Example 4. If $P(x) = x^2 - 5x + 6$ divide $P(x)$ by $(x - 4)$ and show that the remainder is equal to $P(4)$.

Solution: Let's divide $P(x)$ by $(x - 4)$ like the following and the remainder is 2.

$$\begin{array}{r} x - 4 \overline{) x^2 - 5x + 6} \\ \underline{x^2 - 4x} \\ -x + 6 \\ \underline{-x + 4} \\ 2 \end{array}$$

Since $P(4) = 4^2 - 5(4) + 6 = 2$, remainder is equal to $P(4)$.

Example 5. If $P(x) = ax^3 + bx + c$, divide $P(x)$ by $x - m$ and show that the remainder is equal to $P(m)$.

Solution: Divide $P(x)$ by $x - m$ like the following and the remainder is $am^3 + bm + c$.

$$\begin{array}{r} x - m \overline{) ax^3 + bx + c} \\ \underline{ax^3 - amx^2} \\ amx^2 + bx + c \\ \underline{amx^2 - am^2x} \\ (am^2 + b)x + c \\ \underline{(am^2 + b)x - (am^2 + b)m} \\ am^3 + bm + c \end{array}$$

Again, $P(m) = am^3 + bm + c$. So when $P(x)$ is divided by m remainder is equal to $P(m)$.

These two examples suggest the following propositions.

Proposition 1 (Remainder Theorem). If $P(x)$ is a polynomial of positive degree and a is any definite number, the remainder of the division of $P(x)$ by $x - a$ will be $P(a)$.

Proof: If we divide $P(x)$ by $x - a$ the remainder is either 0 or a non-zero constant. Suppose, the remainder is R and the quotient is $Q(x)$, then by law of division, for all x .

$$P(x) = (x - a)Q(x) + R$$

Putting $x = a$ in (i) we get, $P(a) = 0 \cdot Q(a) + R = R$. Therefore, the remainder of $P(x)$ upon division by $x - a$ is $P(a)$.

Example 6. Divide $P(x) = x^3 - 8x^2 + 6x + 60$ by $x + 2$ and find the remainder.

Solution: Since, $x + 2 = x - (-2) = (x - a)$ where $a = -2$,

Hence, remainder = $P(-2) = (-2)^3 - 8(-2)^2 + 6(-2) + 60 = 8$

it is proved by following Proposition 1.

Proposition 2. If $P(x)$ is a polynomial of positive degree and $a \neq 0$, the remainder of the division of $P(x)$ by $ax + b$ will be $P\left(-\frac{b}{a}\right)$.

Example 7. Divide $P(x) = 36x^2 - 8x + 5$ by $(2x - 1)$ and find the remainder.

Solution: The remainder is $P\left(\frac{1}{2}\right) = 36\left(\frac{1}{2}\right)^2 - 8\left(\frac{1}{2}\right) + 5 = 9 - 4 + 5 = 10$

Example 8. If dividing $P(x) = 5x^3 + 6x^2 - ax + 6$ by $x - 2$ results the remainder 6 then find the value of a .

Solution: Dividing $P(x)$ by $x - 2$, we will get the remainder

$$P(2) = 5(2)^3 + 6(2)^2 - a(2) + 6 = 40 + 24 - 2a + 6 = 70 - 2a$$

By the given condition, $70 - 2a = 6$ or, $2a = 70 - 6 = 64$ hence, $a = 32$

Example 9. If $P(x) = x^3 + 5x^2 + 6x + 8$ yields the same remainder upon division by $x - a$ and $x - b$ where $a \neq b$, show that, $a^2 + b^2 + ab + 5a + 5b + 6 = 0$.

Solution: Dividing $P(x)$ by $x - a$ yields remainder, $P(a) = a^3 + 5a^2 + 6a + 8$,

and dividing $P(x)$ by $x - b$ yields remainder, $P(b) = b^3 + 5b^2 + 6b + 8$.

by the given condition, $a^3 + 5a^2 + 6a + 8 = b^3 + 5b^2 + 6b + 8$

$$\text{or, } a^3 - b^3 + 5(a^2 - b^2) + 6(a - b) = 0$$

$$\text{or, } (a - b)(a^2 + b^2 + ab + 5a + 5b + 6) = 0$$

$\therefore a^2 + b^2 + ab + 5a + 5b + 6 = 0$, since $a \neq b$

Proposition 3 (Factor Theorem). If $P(x)$ is a polynomial of positive degree and if $P(a) = 0$, so $x - a$ is a factor of $P(x)$.

Proof: The remainder of $P(x)$ upon division by $x - a$ is $P(a) = 0$ [given]. This means, the polynomial $P(x)$ is divisible by $x - a$. $\therefore x - a$ is a factor of the polynomial $P(x)$.

Converse of Factor Theorem

Proposition 4. If $x - a$ is a factor of the polynomial $P(x)$, show that $P(a) = 0$.

Proof: Since $x - a$ is a factor of $P(x)$, there exists a polynomial $Q(x)$ that $P(x) = (x - a)Q(x)$. Putting $x = a$ we get, $P(a) = (a - a)Q(a) = 0 \cdot Q(a) = 0$.

Example 10. Show that $x - 1$ will be a factor of $P(x) = ax^3 + bx^2 + cx + d$, if and only if $a + b + c + d = 0$.

Solution: Suppose, $a + b + c + d = 0$

then, $P(1) = a + b + c + d = 0$ [by conditions]

Therefore, $x - 1$ is a factor of $P(x)$. [by factor theorem]

Now let's assume $x - 1$ is a factor of $P(x)$.

So, by the converse of factor theorem we get, $P(1) = 0$ i.e., $a + b + c + d = 0$

Remarks: In general, $x - 1$ will be a factor of a polynomial of positive degree if and only if the sum of the coefficient of the polynomial is 0.

Example 11. Suppose, $P(x) = ax^3 + bx^2 + cx + d$ is a polynomial with integer coefficients, $a \neq 0$, $d \neq 0$; suppose $x - r$ is a factor of $P(x)$ show that,

- 1) If r is an integer, r will be factor of the constant term.

- 2) If $r = \frac{p}{q}$ is a rational number in its reduced form, p will be a factor of d , and q will be a factor of a .

Solution:

- 1) From factor theorem, we get, $P(r) = ar^3 + br^2 + cr + d = 0$ or, $(ar^2 + br + c)r = -d$ Since $(ar^2 + br + c)$, r and d are integers, this implies, r is a factor of d .

- 2) From the converse of factor theorem we get,

$$P(r) = ar^3 + br^2 + cr + d = 0$$

$$\text{or, } P\left(\frac{p}{q}\right) = a\left(\frac{p}{q}\right)^3 + b\left(\frac{p}{q}\right)^2 + c\left(\frac{p}{q}\right) + d = 0$$

$$\text{or, } ap^3 + bp^2q + cpq^2 + dq^3 = 0 \dots\dots (1)$$

$$\text{From (1) we get } (ap^2 + bpq + cq^2)p = -dq^3 \dots\dots (2)$$

$$\text{and } (bp^2 + cpq + dq^2)q = -ap^3 \dots\dots (3)$$

Now, $ap^2 + bpq + cq^2$, $bp^2 + cpq + dq^2$, p , q , d , a are integers.

From (2) we get that p is a factor of dq^3 ; from (3) we get that q is a factor of ap^3 . But p and q have no common factor except ± 1 . Therefore, p is a factor of d , and q is a factor of a .

Note: From the above example we see that to determine the factor of integer coefficient of the polynomial $P(x)$ by factor theorem first we can test $P(r)$ and then $P\left(\frac{r}{s}\right)$ where r is the factor with $(r = \pm 1)$ the constant of polynomial and s is the factor with $(s = \pm 1)$ leading coefficient of the polynomial.

Example 12. Resolve the polynomial $P(x) = x^3 - 6x^2 + 11x - 6$ into factors.

Solution: All coefficients of the given polynomial are integers and constant = -6 , leading coefficient = 1

Now if r is an integer and $P(x)$ any factor of the form $x - r$ then, r will be the factor of the constant term -6 . So possible values of r is either of ± 1 , ± 2 , ± 3 , ± 6 . Now for these values of r verify values of $P(x)$.

$$P(1) = 1 - 6 + 11 - 6 = 0, \therefore x - 1, \text{ is a factor of } P(x).$$

$$P(-1) = -1 - 6 - 11 - 6 \neq 0, \therefore x + 1, \text{ is not a factor of } P(x).$$

$$P(2) = 8 - 24 + 22 - 6 = 0, \therefore x - 2, \text{ is a factor of } P(x)$$

$P(-2) = -8 - 24 - 22 - 6 \neq 0$, $\therefore x + 2$, is not a factor of $P(x)$.

$P(3) = 27 - 54 + 33 - 6 = 0$, $\therefore x - 3$, is a factor of $P(x)$.

As degree of $P(x)$ is 3 and we have found three factors of degree 1, so if $P(x)$ has another factor it will be a constant.

$\therefore P(x) = k(x - 1)(x - 2)(x - 3)$ where k is a constant.

Equating the coefficients of the highest power of x appearing on both sides, we get, $k = 1$

Therefore, $P(x) = (x - 1)(x - 2)(x - 3)$

Note: To resolve into factor of the polynomial $P(x)$ first we determine the factor of type $(x - r)$ and then divide directly $P(x)$ by $(x - r)$ or rearrange the terms of $P(x)$ in the form $P(x) = (x - r)Q(x)$. Where the degree of $Q(x)$ is less than degree of $P(x)$ by 1. Then process by determining factors of $Q(x)$

Example 13. Resolve into factors: $18x^3 + 15x^2 - x - 2$

Solution: Let, $P(x) = 18x^3 + 15x^2 - x - 2$

Here, constant terms of $P(x)$ is -2 and the set of its factors $F_1 = \{1, -1, 2, -2\}$.

The set of factors of leading co-efficient of 18 is

$$F_2 = \{1, -1, 2, -2, 3, -3, 6, -6, 9, -9, 18, -18\}$$

Now consider $P(a)$ where, $a = \frac{r}{s}$ and $r \in F_1$, $s \in F_2$

if $a = 1$ then, $P(1) = 18 + 15 - 1 - 2 \neq 0$

if $a = -1$ then, $P(-1) = -18 + 15 + 1 - 2 \neq 0$

if $a = -\frac{1}{2}$, then $P\left(-\frac{1}{2}\right) = 18\left(-\frac{1}{8}\right) + 15\left(\frac{1}{4}\right) + \frac{1}{2} - 2 = 0$

therefore, $x + \frac{1}{2} = \frac{1}{2}(2x + 1)$ i.e., $(2x + 1)$, is a factor of $P(x)$.

Now, $18x^3 + 15x^2 - x - 2 = 18x^3 + 9x^2 + 6x^2 + 3x - 4x - 2$

$$= 9x^2(2x + 1) + 3x(2x + 1) - 2(2x + 1) = (2x + 1)(9x^2 + 3x - 2)$$

And $9x^2 + 3x - 2 = 9x^2 + 6x - 3x - 2 = 3x(3x + 2) - 1(3x + 2) = (3x + 2)(3x - 1)$

$\therefore P(x) = (2x + 1)(3x + 2)(3x - 1)$

Example 14. Resolve $-3x^2 - 2xy + 8y^2 + 11x - 8y - 6$ into factors.

Solution: Considering only the terms of x and constant, we get $-3x^2 + 11x - 6$

$$-3x^2 + 11x - 6 \equiv (-3x + 2)(x - 3) \text{ or } (3x - 2)(-x + 3) \dots \dots (1)$$

Again only considering terms of y and constant, we get $8y^2 - 8y - 6$

$$8y^2 - 8y - 6 \equiv (4y + 2)(2y - 3) \text{ or } (-4y - 2)(-2y + 3) \dots \dots (2)$$

combining factors of above (1) and (2) factors of the given polynomial can be found, but the constants $+2, -3$ or $-2, +3$ must be same in both equations just like the coefficients of x and y .

\therefore factors are $(-3x + 4y + 2)(x + 2y - 3)$ or $(3x - 4y - 2)(-x - 2y + 3)$.

To verify the factors we can check the co-efficient of xy $-3 \cdot 2 + 4 \cdot 1 = -2$ or $3 \cdot (-2) - 4 \cdot (-1) = -2$

Activity:

- 1) if $P(x) = 2x^4 - 6x^3 + 5x - 2$, then determine the remainder by dividing $P(x)$ by the following polynomials.

(1) $x - 1$

(2) $x - 2$

(3) $x + 2$

(4) $x + 3$

(5) $2x - 1$

(6) $2x + 1$

- 2) Find the remainder by using the Remainder Theorem.

(1) Dividend : $4x^3 - 7x + 10$, Divisor: $x - 2$

(2) Dividend: $5x^3 - 11x^2 - 3x + 4$, Divisor: $x + 1$

(3) Dividend: $2y^3 - y^2 - y - 4$, Divisor: $y + 3$

(4) Dividend: $2x^3 + x^2 - 18x + 10$, Divisor: $2x + 1$

- 3) Show that $(x - 1)$ is a factor of $3x^3 - 4x^2 + 4x - 3$.

- 4) if $x + 3$ is a factor of polynomial $2x^3 + x^2 + ax - 9$, then find the value of a .

- 5) Show that $x - 3$ is a factor of polynomial $x^3 - 4x^2 + 4x - 3$.

- 6) If $P(x) = 2x^3 - 5x^2 + 7x - 8$ is a polynomial, find the remainder by using the Remainder Theorem when $P(x)$ is divided by $x - 2$.

- 7) Show that, $x + 1$ and $x - 1$ are two common factors of polynomial $4x^4 - 5x^3 + 5x - 4$.

8) Resolve into factors:

$$(1) \quad x^3 + 2x^2 - 5x - 6$$

$$(2) \quad x^3 + 4x^2 + x - 6$$

$$(3) \quad a^3 - a^2 - 10a - 8$$

$$(4) \quad x^4 + 3x^3 + 5x^2 + 8x + 5$$

$$(5) \quad -2x^2 + 6y^2 + xy + 8x - 2y - 8$$

Homogeneous, Symmetric and Cyclic Expressions

Homogeneous Polynomial: If each term of a polynomial has the same degree, it is called **homogeneous polynomial**. The expression $x^2 + 2xy + 5y^2$ is a homogeneous polynomial of the variable x, y with two degree (each term having degree 2).

It is a special case of the homogeneous polynomial $ax^2 + 2hxy + by^2$ of degree two in two variables x, y where, a, h, b are definite numbers. Considering x, y, a, h, b the variables, $ax^2 + 2hxy + by^2$ is homogeneous polynomial of degree 3. $2x^2y + y^2z + 9z^2x - 5xyz$ is a homogeneous polynomial of the variables x, y, z each term having degree 3.

(Symmetric Expression): An expression with more than one variable, which remains unchanged when any two of its variables are interchanged is called **symmetric expression**.

The expression $a + b + c$ is symmetric expression of the variables, a, b, c because the expression remains unchanged when any two of the variables are interchanged. Similarly, $ab + bc + ca$ of the variables a, b, c and $x^2 + y^2 + z^2 + xy + yz + zx$ are symmetric expression of the variables x, y, z .

But $2x^2 + 5xy + 6y^2$ is not a symmetric expression of the variables x and y Because interchanging x and y it becomes $2y^2 + 5xy + 6x^2$ which is different from former expression.

(Cyclic Expression): An expression with three variables, which remain unchanged when the first variable is replaced by the second, the second variable is replaced by the third and the third variable is replaced by the first variable is called **(cyclically symmetric expression)**. If the replacing of the variables is done cycle-wise like the adjacent figure, it is called cyclically symmetric expression.

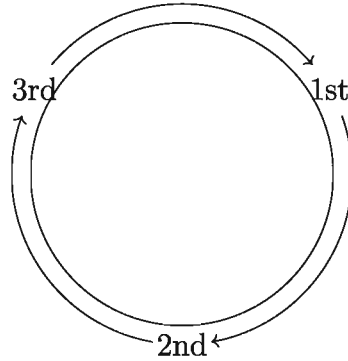

$x^2 + y^2 + z^2 + xy + yz + zx$ is a cyclic expression of the variables x, y, z because replacing x by y , y by z and z by x the expression remains the same. Similarly the expression $x^2y + y^2z + z^2x$ is a cyclic expression of variable x, y, z .

The expression $x^2 - y^2 + z^2$ is not cyclic because replacing x by y , y by z and z by x the expression becomes $y^2 - z^2 + x^2$ which is different from the former expression.

Clearly, every symmetric expression in three variables is cyclic. But not every cyclic expression is symmetric. For example, the expression, $x^2(y - z) + y^2(z - x) + z^2(x - y)$ is cyclic, not symmetric. For interchanging x and y it becomes $y^2(x - z) + x^2(z - y) + z^2(y - x)$, which is different from the former expression.

Observation: For the convenience of description, the expression of variable x, y is indexed by $F(x, y)$ and that of variable x, y, z is indexed by $F(x, y, z)$

Activity: Show that, $\frac{x}{y} + \frac{y}{z} + \frac{z}{x}$ is cyclic but not symmetric.

Resolve into factors of cyclic polynomials

There is no hard and fast rule for factorizing polynomials. Often a factor can be found by suitable rearranging the terms. Sometimes assuming the expression as polynomial of the variable, we determine one or more than one factors by the factor theorem and considering the cyclic and symmetric properties of the expression, we determine the remaining factors.

In this regard, it may be noted that, of the variable, a, b, c

- 1) If $(a - b)$ be the factor of a cyclic polynomial then, $(b - c)$ and $(c - a)$ will be the factor of that polynomial.

- 2) $k(a + b + c)$ and $k(a^2 + b^2 + c^2) + m(ab + bc + ca)$ are the homogeneous and cyclic polynomial of degree 1 and 2 where k and m are constant.
- 3) If the values of two polynomials are equal for all values of the variables, the coefficient of the corresponding two terms of the polynomial will be equal.

Example 15. Resolve into factors $bc(b - c) + ca(c - a) + ab(a - b)$

Solution: Here two methods are shown.

$$\begin{aligned}
 &\text{First Method: } bc(b - c) + ca(c - a) + ab(a - b) \\
 &= bc(b - c) + c^2a - ca^2 + a^2b - ab^2 \\
 &= bc(b - c) + a^2b - ca^2 - ab^2 + c^2a \\
 &= bc(b - c) + a^2(b - c) - a(b^2 - c^2) \\
 &= bc(b - c) + a^2(b - c) - a(b + c)(b - c) \\
 &= (b - c)\{bc + a^2 - a(b + c)\} \\
 &= (b - c)\{bc + a^2 - ab - ac\} \\
 &= (b - c)\{bc - ab - ac + a^2\} \\
 &= (b - c)\{b(c - a) - a(c - a)\} \\
 &= (b - c)(c - a)(b - a) \\
 &= -(a - b)(b - c)(c - a)
 \end{aligned}$$

Second method: Considering the given expression as a polynomial $P(a)$ in a , we substitute b for a ,

$$P(b) = bc(b - c) + cb(c - b) + b^2(b - b) = 0$$

So $(a - b)$ is a factor of given expression. Similarly $(b - c)$ and $(c - a)$ are factors of given expression.

The product of these three factors is a cyclic homogeneous polynomial of degree 3, as is the given expression. So, any remaining factor must be a constant.

$$\text{i.e., } bc(b - c) + ca(c - a) + ab(a - b) = k(a - b)(b - c)(c - a) \dots \dots (1)$$

where k is a constant. (1) is true for all values of a, b, c

Putting $a = 0, b = 1, c = 2$ in (1),

$$1 \cdot 2(-1) = k(-1)(-1)(2) \quad \therefore k = -1$$

$$\therefore bc(b - c) + ca(c - a) + ab(a - b) = -(a - b)(b - c)(c - a)$$

Example 16. Resolve into factor $a^3(b - c) + b^3(c - a) + c^3(a - b)$.

Solution: Considering given expression a polynomial $P(a)$ in a , we substitute b for a , $P(b) = b^3(b - c) + b^3(c - b) + c^3(b - b) = 0$. So $(a - b)$ is a factor of given expression. As it is a cyclic polynomial both $(b - c)$ and $(c - a)$ are also the factors of given expression. Again the given expression is a cyclic homogeneous polynomial of degree 4 and $(a - b)(b - c)(c - a)$ cyclic homogeneous polynomial of degree 3. So the remaining factor must be a cyclic homogeneous polynomial of degree 1 $k(a + b + c)$, where k is a constant.

$$\therefore a^3(b - c) + b^3(c - a) + c^3(a - b) = k(a - b)(b - c)(c - a)(a + b + c) \dots \dots (1)$$

For all values of a, b, c (1) is true.

So in (1) putting $a = 0, b = 1, c = 2$, we get

$$2 + 8(-1) = k(-1)(-1)(2)(3) \quad \text{or } k = -1$$

In (1) putting $k = -1$, we get

$$a^3(b - c) + b^3(c - a) + c^3(a - b) = -(a - b)(b - c)(c - a)(a + b + c)$$

Example 17. Factorize $(b + c)(c + a)(a + b) + abc$

Solution: Considering the expression $P(a)$ in a substituting $-b - c$ for a ,

$$P(-b - c) = (b + c)(c - b - c)(-b - c + b) + (-b - c)bc = bc(b + c) - bc(b + c) = 0$$

so $(a + b + c)$ is a factor of the expression. The given expression having a cyclic homogeneous polynomial of degree 3 and one factor of degree 1 have been found. So, the remaining factor will be cyclic homogeneous polynomial of degree two, i.e., will be of the form $k(a^2 + b^2 + c^2) + m(bc + ca + ab)$ where k and m are constant.

$$\therefore (b + c)(c + a)(a + b) + abc = (a + b + c)\{k(a^2 + b^2 + c^2) + m(bc + ca + ab)\} \dots (1)$$

(1) is true for all value of a, b, c .

Putting in (1) first $a = 0, b = 0, c = 1$ and then $a = 1, b = 1, c = 0$, we get respectively,

$$0 = k \text{ and } \times 2 + m) \quad \therefore k = 0, m = 1$$

Now, putting the value of k and m , we get $(b + c)(c + a)(a + b) + abc = (a + b + c)(bc + ca + ab)$

By using the similar method of solving Example 15, the expression described in Example 16 and Example 17 can be factorized.

An Important Algebraic Formula: For all values of a, b, c ,

$$a^3 + b^3 + c^3 - 3abc = (a + b + c)(a^2 + b^2 + c^2 - ab - bc - ca)$$

Proof: Two proofs of the formula are given below.

First method (Direct applying algebraic method)

$$\begin{aligned} & a^3 + b^3 + c^3 - 3abc \\ &= (a + b)^3 - 3ab(a + b) + c^3 - 3abc \\ &= (a + b)^3 + c^3 - 3ab(a + b + c) \\ &= (a + b + c)\{(a + b)^2 - (a + b)c + c^2\} - 3ab(a + b + c) \\ &= (a + b + c)(a^2 + 2ab + b^2 - ac - bc + c^2) - 3ab(a + b + c) \\ &= (a + b + c)(a^2 + b^2 + c^2 - ab - bc - ca) \end{aligned}$$

Second method (using properties of homogeneous cyclic expressions)

Considering the expression $a^3 + b^3 + c^3 - 3abc$ a polynomial $P(a)$ of variable a and putting in it, $a = -(b + c)$ we get,

$$P\{-(b + c)\} = -(b + c)^3 + b^3 + c^3 + 3(b + c)bc = (b + c)^3 - (b + c)^3 = 0$$

Therefore, $a + b + c$ is a factor of the expression under consideration. As $a^3 + b^3 + c^3 - 3abc$ is a homogeneous cyclic polynomial of degree 3, the other factor will have the form $k(a^2 + b^2 + c^2) + m(ab + bc + ca)$ where k and m constant. Therefore, for all values of a, b and c

$$a^3 + b^3 + c^3 - 3abc = (a + b + c)\{k(a^2 + b^2 + c^2) + m(ab + bc + ca)\}$$

Here first putting $a = 1, b = 0, c = 0$ and then $a = 1, b = 1, c = 0$ we get, $k = 1$ and $2 = 2(k \times 2 + m)$ i.e., $k = 1$ and $1 = 2 + m \implies m = -1$

$$\therefore a^3 + b^3 + c^3 - 3abc = (a + b + c)(a^2 + b^2 + c^2 - ab - bc - ca)$$

Corollary 1. $a^3 + b^3 + c^3 - 3abc = \frac{1}{2}(a + b + c)\{(a - b)^2 + (b - c)^2 + (c - a)^2\}$

Proof: $a^2 + b^2 + c^2 - ab - bc - ca$

$$\begin{aligned} &= \frac{1}{2}(2a^2 + 2b^2 + 2c^2 - 2ab - 2bc - 2ca) \\ &= \frac{1}{2}\{(a^2 - 2ab + b^2) + (b^2 - 2bc + c^2) + (c^2 - 2ca + a^2)\} \\ &= \frac{1}{2}\{(a - b)^2 + (b - c)^2 + (c - a)^2\} \end{aligned}$$

$$\therefore a^3 + b^3 + c^3 - 3abc = \frac{1}{2}(a + b + c)\{(a - b)^2 + (b - c)^2 + (c - a)^2\}$$

Corollary 2. if $a + b + c = 0$, then $a^3 + b^3 + c^3 = 3abc$

Corollary 3. if $a^3 + b^3 + c^3 = 3abc$, so $a + b + c = 0$ or $a = b = c$

Example 18. Factorize $(a - b)^3 + (b - c)^3 + (c - a)^3$.

Solution: Let $A = a - b$, $B = b - c$, $C = c - a$

then, $A + B + C = a - b + b - c + c - a = 0$

Therefore, $A^3 + B^3 + C^3 = 3ABC$

i.e., $(a - b)^3 + (b - c)^3 + (c - a)^3 = 3(a - b)(b - c)(c - a)$

Activity: Factorize:

1) (1) $a(b^2 - c^2) + b(c^2 - a^2) + c(a^2 - b^2)$

(2) $a^2(b - c) + b^2(c - a) + c^2(a - b)$

(3) $a(b - c)^3 + b(c - a)^3 + c(a - b)^3$

(4) $bc(b^2 - c^2) + ca(c^2 - a^2) + ab(a^2 - b^2)$

(5) $a^4(b - c) + b^4(c - a) + c^4(a - b)$

(6) $a^2(b - c)^3 + b^2(c - a)^3 + c^2(a - b)^3$

(7) $x^4(y^2 - z^2) + y^4(z^2 - x^2) + z^4(x^2 - y^2)$

(8) $a^3(b - c) + b^3(c - a) + c^3(a - b)$

2) if $\frac{x^2 - yz}{a} = \frac{y^2 - zx}{b} = \frac{z^2 - xy}{c} \neq 0$,

show that, $(a + b + c)(x + y + z) = ax + by + cz$

3) if $(a + b + c)(ab + bc + ca) = abc$, show that, $(a + b + c)^3 = a^3 + b^3 + c^3$

Rational Fractions

Fraction formed with a polynomial as denominator and a polynomial as numerator is called the rational fraction. For example, $\frac{x}{(x - a)(x - b)}$ and $\frac{a^2 + a + 1}{(a - b)(a - c)}$ is a rational fraction.

Example 19. Simplify: $\frac{a}{(a - b)(a - c)} + \frac{b}{(b - c)(b - a)} + \frac{c}{(c - a)(c - b)}$

Solution:

$$\frac{a}{(a - b)(a - c)} + \frac{b}{(b - c)(b - a)} + \frac{c}{(c - a)(c - b)}$$

$$= -\frac{a}{(a - b)(c - a)} - \frac{b}{(b - c)(a - b)} - \frac{c}{(c - a)(b - c)}$$

$$= \frac{a(b-c) + b(c-a) + c(a-b)}{-(a-b)(b-c)(c-a)}$$

$$= \frac{0}{-(a-b)(b-c)(c-a)} = 0$$

Example 20. Simplify: $\frac{a^2 - (b-c)^2}{(a+c)^2 - b^2} + \frac{b^2 - (c-a)^2}{(a+b)^2 - c^2} + \frac{c^2 - (a-b)^2}{(b+c)^2 - a^2}$

Solution: 1st fraction = $\frac{(a+b-c)(a-b+c)}{(a+b+c)(a-b+c)} = \frac{a+b-c}{a+b+c}$

2nd fraction = $\frac{(a+b-c)(b-a+c)}{(a+b+c)(a+b-c)} = \frac{b+c-a}{a+b+c}$

3rd fraction = $\frac{(c+a-b)(c-a+b)}{(a+b+c)(b+c-a)} = \frac{c+a-b}{a+b+c}$

\therefore given expression $\frac{a+b-c}{a+b+c} + \frac{b+c-a}{a+b+c} + \frac{c+a-b}{a+b+c}$

$$= \frac{a+b-c+b+c-a+c+a-b}{a+b+c} = \frac{a+b+c}{a+b+c} = 1$$

Example 21. Simplify: $\frac{(ax+1)^2}{(x-y)(z-x)} + \frac{(ay+1)^2}{(x-y)(y-z)} + \frac{(az+1)^2}{(y-z)(z-x)}$

Solution: Given expression

$$\frac{(ax+1)^2}{(x-y)(z-x)} + \frac{(ay+1)^2}{(x-y)(y-z)} + \frac{(az+1)^2}{(y-z)(z-x)}$$

$$= \frac{(ax+1)^2(y-z) + (ay+1)^2(z-x) + (az+1)^2(x-y)}{(x-y)(y-z)(z-x)} \dots\dots (1)$$

Here numerator of (1)

$$(a^2x^2 + 2ax + 1)(y-z) + (a^2y^2 + 2ay + 1)(z-x) + (a^2z^2 + 2az + 1)(x-y)$$

$$= a^2\{x^2(y-z) + y^2(z-x) + z^2(x-y)\} + 2a\{x(y-z) + y(z-x) + z(x-y)\}$$

$$+ \{(y-z) + (z-x) + (x-y)\}$$

But $x^2(y-z) + y^2(z-x) + z^2(x-y) = -(x-y)(y-z)(z-x)$

and, $x(y-z) + y(z-x) + z(x-y) = 0$ and $(y-z) + (z-x) + (x-y) = 0$

\therefore numerator of (1) $-a^2(x-y)(y-z)(z-x)$

So given expression = $\frac{-a^2(x-y)(y-z)(z-x)}{(x-y)(y-z)(z-x)} = -a^2$

Example 22. Simplify: $\frac{1}{x+a} + \frac{2x}{x^2+a^2} + \frac{4x^3}{x^4+a^4} + \frac{8x^7}{a^8-x^8}$

Solution: The sum of the given 3rd and 4th terms

$$\begin{aligned} &= \frac{4x^3}{x^4+a^4} + \frac{8x^7}{a^8-x^8} = \frac{4x^3}{x^4+a^4} + \frac{8x^7}{(x^4+a^4)(a^4-x^4)} \\ &= \frac{4x^3}{x^4+a^4} \left(1 + \frac{2x^4}{a^4-x^4} \right) = \frac{4x^3}{x^4+a^4} \times \frac{a^4-x^4+2x^4}{a^4-x^4} \\ &= \frac{4x^3}{x^4+a^4} \times \frac{a^4+x^4}{a^4-x^4} = \frac{4x^3}{a^4-x^4} \end{aligned}$$

\therefore the sum of a 2nd, 3rd and 4th terms

$$\begin{aligned} &= \frac{2x}{x^2+a^2} + \frac{4x^3}{a^4-x^4} = \frac{2x}{x^2+a^2} \left[1 + \frac{2x^2}{a^2-x^2} \right] \\ &= \frac{2x}{x^2+a^2} \times \frac{a^2-x^2+2x^2}{a^2-x^2} = \frac{2x}{x^2+a^2} \times \frac{a^2+x^2}{a^2-x^2} = \frac{2x}{a^2-x^2} \end{aligned}$$

\therefore the given expression = $\frac{1}{x+a} + \frac{2x}{a^2-x^2} = \frac{a-x+2x}{a^2-x^2} = \frac{a+x}{a^2-x^2} = \frac{1}{a-x}$

Activity: simplify:

- 1) $\frac{b+c}{(a-b)(a-c)} + \frac{c+a}{(b-c)(b-a)} + \frac{a+b}{(c-a)(c-b)}$
- 2) $\frac{a^3-1}{(a-b)(a-c)} + \frac{b^3-1}{(b-c)(b-a)} + \frac{c^3-1}{(c-a)(c-b)}$
- 3) $\frac{bc(a+d)}{(a-b)(a-c)} + \frac{ca(b+d)}{(b-c)(b-a)} + \frac{ab(c+d)}{(c-a)(c-b)}$
- 4) $\frac{a^3+a^2+1}{(a-b)(a-c)} + \frac{b^3+b^2+1}{(b-c)(b-a)} + \frac{c^3+c^2+1}{(c-a)(c-b)}$
- 5) $\frac{a^2+bc}{(a-b)(a-c)} + \frac{b^2+ca}{(b-c)(b-a)} + \frac{c^2+ab}{(c-a)(c-b)}$

Partial Fractions

If a given fraction is expressed as a sum of two or more fractions, then each of the latter fractions is said to be a **partial fraction** of the given fraction.

Here, the fraction $\frac{3x-8}{x^2-5x+6}$ can be written down:

$$\frac{3x - 8}{x^2 - 5x + 6} = \frac{2(x - 3) + (x - 2)}{(x - 3)(x - 2)} = \frac{2}{x - 2} + \frac{1}{x - 3}$$

Here the given fraction is expressed as the sum of the two fractions i.e., the fraction has been divided into two partial fractions.

If both $N(x)$ and $D(x)$ are the polynomials of the variable x and if the degree of numerator $N(x)$ is less than the denominator $D(x)$, then, the fraction is called **proper fraction**. The degree of numerator $N(x)$ is greater than or equal to that of the denominator $D(x)$ the fraction is called **improper fraction**. For example, $\frac{x^2 + 1}{(x + 1)(x + 2)(x - 3)}$ is a proper fraction. But $\frac{2x^4}{x + 1}$ and $\frac{x^3 + 3x^2 + 2}{x + 2}$ both are improper fractions. We mention that numerator divided by the denominator of the improper fraction in general rule or the terms of the numerator rearranged in a convenient way, the fraction as a polynomial (quotient) and as the sum of the improper fraction can be expressed. For example, $\frac{x^3 + 3x^2 + 2}{x + 2} = (x^2 + x - 2) + \frac{6}{x + 2}$

How to convert the proper rational fraction into the partial fraction in different ways is shown below.

- 1) The denominator is, or can be expressed as a product of distinct linear factors but no factor is repeated.
- 2) When the degree of the numerator is greater than or equal to that of the denominator, then degree of numerator is lessened by dividing the numerator by the denominator.
- 3) The denominator is, or can be expressed as a product of linear factors, some of which are repeated.
- 4) The denominator is or can be expressed as a product of linear and quadratic factor, none of which is repeated.
- 5) The denominator is, or can be expressed as a product of linear and quadratic factors, some of which are repeated.

The denominator is, or can be expressed as a product of distinct linear factors but no factor is repeated

Example 23. Resolve into partial fraction $\frac{5x - 7}{(x - 1)(x - 2)}$

Solution: Let,
$$\frac{5x - 7}{(x - 1)(x - 2)} \equiv \frac{A}{x - 1} + \frac{B}{x - 2} \dots\dots (1)$$

On both sides of (1) multiplying $(x - 1)(x - 2)$,

$$5x - 7 \equiv A(x - 2) + B(x - 1) \dots\dots (2)$$

which is true for all values of x .

Now, on both sides of (2) putting $x = 1$ we get, $5 - 7 = A(1 - 2) + B(1 - 1)$

$$\text{or, } -2 = -A, \therefore A = 2$$

Again, on both sides of (2) putting $x = 2$ we get, $10 - 7 = A(2 - 2) + B(2 - 1)$

$$\text{or, } 3 = B, \therefore B = 3$$

Now putting values of A and B in (1) we get,

$$\frac{5x - 7}{(x - 1)(x - 2)} \equiv \frac{2}{x - 1} + \frac{3}{x - 2};$$
 thus the given fraction is converted into partial fractions.

Remarks: That the given fraction is converted into the partial fraction properly, can be examined.

$$\text{R.H.S.} = \frac{2}{x - 1} + \frac{3}{x - 2} = \frac{2(x - 2) + 3(x - 1)}{(x - 1)(x - 2)} = \frac{5x - 7}{(x - 1)(x - 2)} = \text{L.H.S.}$$

Example 24. Express $\frac{x + 5}{(x - 1)(x - 2)(x - 3)}$ into partial fraction.

Solution: Let,
$$\frac{x + 5}{(x - 1)(x - 2)(x - 3)} \equiv \frac{A}{x - 1} + \frac{B}{x - 2} + \frac{C}{x - 3} \dots\dots (1)$$

on both sides of (1) multiplying $(x - 1)(x - 2)(x - 3)$,

$$x + 5 \equiv A(x - 2)(x - 3) + B(x - 1)(x - 3) + C(x - 1)(x - 2) \dots\dots (2)$$

(2) is true for all values of x

On both sides of (2) putting $x = 1$,

$$1 + 5 = A(-1)(-2) \implies 6 = 2A \implies A = 3$$

Again, on both sides of (2) putting $x = 2$ we get,

$$2 + 5 = B(1)(-1) \implies 7 = -B, \therefore B = -7$$

And on both sides of (2) putting $x = 3$ we get,

$$3 + 5 = C(2)(1) \text{ or, } 8 = 2C \text{ or, } C = 4.$$

Now, the values of A , B and C , putting in (1), we get,

$$\frac{x+5}{(x-1)(x-2)(x-3)} \equiv \frac{3}{x-1} - \frac{7}{x-2} + \frac{4}{x-3}$$

When the degree of the numerator is greater than or equal to that of the denominator, then degree of numerator is lessened by dividing the numerator by the denominator.

Example 25. Express $\frac{(x-1)(x-5)}{(x-2)(x-4)}$ into partial fraction.

Solution: Here dividing numerator by denominator, we get 1.

$$\text{Let, } \frac{(x-1)(x-5)}{(x-2)(x-4)} \equiv 1 + \frac{A}{x-2} + \frac{B}{x-4} \dots\dots\dots (1)$$

Multiplying $(x-2)(x-4)$ on both sides of (1)

$$(x-1)(x-5) \equiv (x-2)(x-4) + A(x-4) + B(x-2) \dots\dots\dots (2)$$

On both sides of (2) putting $x = 2, 4$ respectively

$$(2-1)(2-5) = A(2-4) \text{ or, } A = \frac{3}{2}$$

$$\text{And } (4-1)(4-5) = B(4-2) \text{ or, } B = \frac{-3}{2}$$

Now putting values of A and B in (1) we get,

$$\frac{(x-1)(x-5)}{(x-2)(x-4)} \equiv 1 + \frac{3}{2(x-2)} - \frac{3}{2(x-4)} \text{ which is the desired partial fraction.}$$

Example 26. Express $\frac{2x^3}{(x-1)(x-2)(x-3)}$ into partial fraction.

Solution: Dividing numerator by denominator, we get 2

$$\text{Let, } \frac{2x^3}{(x-1)(x-2)(x-3)} \equiv 2 + \frac{A}{x-1} + \frac{B}{x-2} + \frac{C}{x-3} \dots\dots\dots (1)$$

On both sides of (1) multiplying $(x-1)(x-2)(x-3)$ we get,

$$2x^3 \equiv 2(x-1)(x-2)(x-3) + A(x-2)(x-3) + B(x-1)(x-3) + C(x-1)(x-2) \dots\dots\dots (2)$$

On both sides of (2) putting $x = 1, 2, 3$ we get,

$$2 = A(-1)(-2) \text{ or, } A = 1; \quad 16 = B(1)(-1) \text{ or, } B = -16$$

$$\text{and } 54 = C(2)(1) \text{ or, } C = \frac{54}{2} = 27$$

Now putting the values of A , B , C in (1) we get,

$\frac{2x^3}{(x-1)(x-2)(x-3)} \equiv 2 + \frac{1}{x-1} - \frac{16}{x-2} + \frac{27}{x-3}$ which is desired partial fraction.

The denominator is, or can be expressed as a product of linear factors, some of which are repeated.

Example 27. Express $\frac{x}{(x-1)^2(x-2)}$ as partial fraction.

Solution: Let $\frac{x}{(x-1)^2(x-2)} \equiv \frac{A}{x-1} + \frac{B}{(x-1)^2} + \frac{C}{x-2}$

on both sides of (1) multiplying $(x-1)^2(x-2)$, we get

$$x \equiv A(x-1)(x-2) + B(x-2) + C(x-1)^2 \dots \dots (1)$$

on both sides of (2) putting $x = 1$, 2 respectively, we get

$$1 = B(1-2) \text{ or, } B = -1 \text{ and } 2 = C(2-1)^2 \text{ or, } 2 = C \implies C = 2$$

Again, Equating the coefficients of x^2 on both sides of (2), we get

$$0 = A + C \text{ or, } A = -C = -2$$

Now putting the values of A , B and C in (1), we get

$\frac{x}{(x-1)^2(x-2)} \equiv \frac{-2}{x-1} + \frac{-1}{(x-1)^2} + \frac{2}{x-2}$ which is the desired partial fraction.

The denominator is or can be expressed as a product of linear and quadratic factor, none of which is repeated.:

Example 28. Express $\frac{x}{(x-1)(x^2+4)}$ as partial fraction.

Solution: Let, $\frac{x}{(x-1)(x^2+4)} \equiv \frac{A}{x-1} + \frac{Bx+C}{x^2+4} \dots \dots (1)$

On both sides multiplying by $(x-1)(x^2+4)$, we get

$$x \equiv A(x^2+4) + (Bx+C)(x-1) \dots \dots (2)$$

in (2) putting $x = 1$, we get

$$1 = A(5) \implies A = \frac{1}{5}$$

Equating coefficients of x^2 and x ,

$$A + B = 0 \dots (3) \text{ and } C - B = 1 \dots (4)$$

in (3) putting $A = \frac{1}{5}$ we get, $B = -\frac{1}{5}$

in (4) putting $B = -\frac{1}{5}$ we get, $C = \frac{4}{5}$

Now putting the values of A , B and C in (1), we get

$$\frac{x}{(x-1)(x^2+4)} \equiv \frac{\frac{1}{5}}{x-1} + \frac{-\frac{x}{5} + \frac{4}{5}}{x^2+4} = \frac{1}{5(x-1)} - \frac{x-4}{5(x^2+4)}$$

which is the desired partial fraction.

The denominator is, or can be expressed as a product of linear and quadratic factors, some of which are repeated.

Example 29. Express $\frac{1}{x(x^2+1)^2}$ as partial fraction.

Solution: Let, $\frac{1}{x(x^2+1)^2} \equiv \frac{A}{x} + \frac{Bx+C}{x^2+1} + \frac{Dx+E}{(x^2+1)^2} \dots \dots (1)$

Multiplying both sides of (1) by $x(x^2+1)^2$, we get

$$\begin{aligned} 1 &\equiv A(x^2+1)^2 + (Bx+C)(x^2+1)x + (Dx+E)x \\ &\equiv A(x^4+2x^2+1) + (Bx+C)(x^3+x) + Dx^2 + Ex \end{aligned}$$

$$\text{or, } 1 \equiv Ax^4 + 2Ax^2 + A + Bx^4 + Bx^2 + Cx^3 + Cx + Dx^2 + Ex \dots \dots (2)$$

on both sides of (2) equating the co-efficients of x^4 , x^3 , x^2 , x and the constant we get,

$$A + B = 0, \quad C = 0, \quad 2A + B + D = 0, \quad C + E = 0, \quad A = 1$$

$$\text{in } C + E = 0 \text{ putting } C = 0, \text{ we get } E = 0$$

$$\text{in } A + B = 0 \text{ putting } A = 1, \text{ we get } B = -1$$

$$\text{in } 2A + B + D = 0 \text{ putting } A = 1 \text{ and } B = -1, \text{ we get } D = -1$$

$$\therefore A = 1, \quad B = -1, \quad C = 0, \quad D = -1 \text{ and } E = 0$$

in (1) putting values of A , B , C , D and E , we get

$\frac{1}{x(x^2+1)^2} \equiv \frac{1}{x} - \frac{x}{x^2+1} - \frac{x}{(x^2+1)^2}$ which is the desired partial fraction.

Activity: Express in partial fraction:

1) $\frac{x^2 + x + 1}{x^3 + x^2 - 6x}$

2) $\frac{x^2}{x^4 + x^2 - 2}$

3) $\frac{x^3}{x^4 + 3x^2 + 2}$

4) $\frac{x^2}{(x-1)^3(x-2)}$

5) $\frac{1}{1-x^3}$

6) $\frac{2x}{(x+1)(x^2+1)^2}$

Exercise 2

1. Which one of the following expression is symmetric?

1) $a + b + c$ 2) $xy - yz + zx$ 3) $x^2 - y^2 + z^2$ 4) $2a^2 - 5bc - c^2$

2. if $P(x, y, z) = x^3 + y^3 + z^3 - 3xyz$ then

(i) $P(x, y, z)$ cyclic

(ii) $P(x, y, z)$ symmetric

(iii) $P(1, -2, 1) = 0$

which one of the following is correct?

1) i, ii 2) i, iii 3) ii, iii 4) i, ii, iii

If one of the factor of $x^3 + px^2 - x - 7$ polynomial is $x + 7$ then answer the following 3 and 4.

3. What is the value of p ?

1) -7 2) 7 3) $\frac{54}{7}$ 4) 477

4. What is the product of the other factors of the polynomial?

1) $(x-1)(x-1)$ 2) $(x+1)(x-2)$ 3) $(x-1)(x+3)$ 4) $(x+1)(x-1)$

5. If a factor of polynomial $x^4 - 5x^3 + 7x^2 - a$ is $x - 2$ then, show that, $a = 4$

6. Suppose, $P(x) \equiv ax^5 + bx^4 + cx^3 + cx^2 + bx + a$ where a, b, c are constant and $a \neq 0$. Show that, if $x - r$ is a factor of $P(x)$, then another factor of $P(x)$ will be $(rx - 1)$

7. Resolve into factors:

1) $x^4 + 7x^3 + 17x^2 + 17x + 6$

2) $4a^4 + 12a^3 + 7a^2 - 3a - 2$

3) $x^3 + 2x^2 + 2x + 1$

- 4) $x(y^2 + z^2) + y(z^2 + x^2) + z(x^2 + y^2) + 3xyz$
- 5) $(x + 1)^2(y - z) + (y + 1)^2(z - x) + (z + 1)^2(x - y)$
- 6) $b^2c^2(b^2 - c^2) + c^2a^2(c^2 - a^2) + a^2b^2(a^2 - b^2)$
- 7) $15x^2 + 2xy - 24y^2 - x + 24y - 6$
- 8) $15x^2 - 24y^2 - 6z^2 + 2xy - xz + 24yz$
8. if $\frac{1}{a^3} + \frac{1}{b^3} + \frac{1}{c^3} = \frac{3}{abc}$, show that, $bc + ca + ab = 0$ or, $a = b = c$
9. if $x = b + c - a$, $y = c + a - b$, and $z = a + b - c$ show that,
 $x^3 + y^3 + z^3 - 3xyz = 4(a^3 + b^3 + c^3 - 3abc)$
10. Simplify:
- 1) $\frac{a^2}{(a-b)(a-c)} + \frac{b^2}{(b-c)(b-a)} + \frac{c^2}{(c-a)(c-b)}$
- 2) $\frac{(a+b)^2 - ab}{(b-c)(a-c)} + \frac{(b+c)^2 - bc}{(c-a)(b-a)} + \frac{(c+a)^2 - ca}{(a-b)(c-b)}$
- 3) $\frac{a}{(a-b)(a-c)(x-a)} + \frac{b}{(b-c)(b-a)(x-b)} + \frac{c}{(c-a)(c-b)(x-c)}$
- 4) $\frac{1}{(1+x)} + \frac{2}{(1+x^2)} + \frac{4}{(1+x^4)} + \frac{8}{(1+x^8)} + \frac{16}{(x^{16}-1)}$
11. Express as partial fraction:
- 1) $\frac{5x+4}{x(x+2)}$
- 2) $\frac{x+2}{x^2-7x+12}$
- 3) $\frac{x^2-9x-6}{x(x-2)(x+3)}$
- 4) $\frac{x^2-4x-7}{(x+1)(x^2+4)}$
- 5) $\frac{x^2}{(2x+1)(x+3)^2}$
12. The polynomial of x, y, z , $F(x, y, z) = x^3 + y^3 + z^3 - 3xyz$
- 1) Show that, $F(x, y, z)$ is a cyclic expression.
- 2) Factorize $F(x, y, z)$ and if $F(x, y, z) = 0$, $(x + y + z) \neq 0$ show that,
 $x^2 + y^2 + z^2 = xy + yz + zx$
- 3) if $x = (b + c - a)$, $y = (c + a - b)$ and $z = (a + b - c)$ show that,
 $F(a, b, c) : F(x, y, z) = 1 : 4$
13. $P(a, b, c) = (a + b + c)(ab + bc + ca)$ and $Q = a^{-3} + b^{-3} + c^{-3} - 3a^{-1}b^{-1}c^{-1}$
- 1) Express with proper reason whether $P(a, b, c)$ cyclic or symmetric.

- 2) if $Q = 0$ prove that, $a = b = c$ or $ab + bc + ca = 0$
 - 3) if $P(a, b, c) = abc$ show that, $\frac{1}{(a + b + c)^7} = \frac{1}{a^7} + \frac{1}{b^7} + \frac{1}{c^7}$
14. $P(x) = 18x^3 + bx^2 - x - 2$ and $Q(x) = 4x^4 + 12x^3 + 7x^2 - 3x - 2$
- 1) Determine the degree of the quotient $\frac{Q(x)}{P(x)}$
 - 2) if $3x + 2$ is a factor of $P(x)$, find the value of b .
 - 3) Express $\frac{8x^2 - 2}{Q(x)}$ as partial fraction.
15. Two polynomials of variable x are $P(x) = 7x^2 - 3x + 4x^4 - a + 12x^3$ and $Q(x) = 6x^3 + x^2 - 9x + 26$
- 1) Expressing $P(x)$ ideally determine leading co-efficient.
 - 2) A factor of $P(x)$ is $(x + 2)$ then find the value of a .
 - 3) Show that there is a common factor of $P(x)$ and $Q(x)$.

Chapter 3

Geometry

In the Geometry section of the Mathematics book of class 8 and class 9-10, the theorem of Pythagoras and its converse have been discussed in detail. In learning mathematics, the subjects related to this play a very important role. So, in the light of the theorem of Pythagoras, more discussion is necessary in *Secondary Higher Mathematics*. For this discussion, one needs to have a clear conception of orthogonal projection. With this objective in mind, the theorem of Pythagoras is discussed in briefly the first part of this stage, while at the second stage the conception of orthogonal projection and the corollary of the Pythagoras theorem will be discussed. In the concluding part of the discussion, some problems will be included for logical discussion and proof on the basis of theorem of Pythagoras and its extended conception .

At the end of this chapter, the students will be able to –

- ▶ explain the conception of orthogonal projection;
- ▶ prove and apply the theorems on the basis of the theorem of Pythagoras;
- ▶ prove and apply the theorems of the circumcentre, centroid and orthocenter;
- ▶ prove and apply the theorems of Brahmagupta;
- ▶ prove and apply the theorems of Ptolemy.

Review of the Theorem of Pythagoras

About 600 years before the birth of the Christ, the renowned Greek scholar Pythagoras (570–495 BC) described an extremely important theorem about right angled triangles. This theorem was named after him and so known as the theorem of Pythagoras. But it was known even around 1000 years before Pythagoras. Egyptian surveyors had possessed the knowledge about the theorem. The theorem of Pythagoras can be proved in many ways. Two of its

proofs have been taught in lower secondary level. So we will skip its proof. Herein it will contain only its explanation and some brief discussion.

Theorem 1 (Theorem of Pythagoras). In a right angled triangle the area of the square drawn on the hypotenuse is equal to the sum of the areas of the two squares drawn on the other two sides.

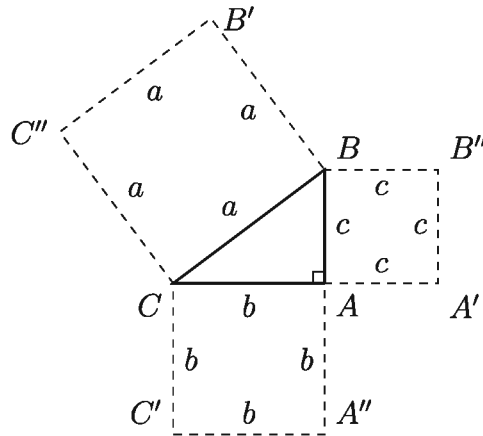

In the figure above ABC is a right angled triangle. $\angle BAC$ is a right angle and BC is hypotenuse. If any square is drawn on the hypotenuse BC , its area is equal to the sum of the areas of the squares drawn on the sides adjacent to the right angle which are AB and AC .

Here $BC^2 =$ the area of the square $BB'C''C = a^2$, $AB^2 =$ the area of the square $AA'B''B = c^2$, and $CA^2 =$ the area of the square $CC'A''A = b^2$.

Therefore, $BC^2 = AB^2 + AC^2$ or $a^2 = b^2 + c^2$.

For example, if the lengths of the two sides adjacent to the right angle of a right angled triangle are $b = 8$ cm. and $c = 6$ cm, it can be said as per the theorem of Pythagoras that the length of the hypotenuse will be $a = 10$ cm.

Similarly, it is possible to know the length of the third side by the lengths of any two sides.

Theorem 2 (Converse of the Theorem of Pythagoras). If the area of the square on one side of a triangle is equal to the sum of areas of the squares drawn on the other two sides, the angle included by the latter two sides is a right angle.

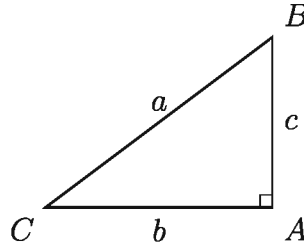

In the figure shown above, three sides of the $\triangle ABC$ are AB , BC and AC . The area of the square drawn on the side BC is equal to the sum of the area of the squares drawn on sides AB and AC . Therefore, $BC^2 = AB^2 + AC^2$ or, $a^2 = b^2 + c^2$. So, $\angle BAC$ is a right angle. For example, we can say that if the lengths AB , BC and CA of $\triangle ABC$ are 6 cm., 10 cm. and 8 cm. respectively, $\angle BAC$ must be a right angle.

Since, $AB^2 = 6^2$ square cm. = 36 square cm.,

$BC^2 = 10^2$ square cm. = 100 square cm.,

$AC^2 = 8^2$ square cm. = 64 square cm.,

$\therefore BC^2 = 100 = 36 + 64 = AB^2 + AC^2$

$\therefore \angle BAC = 90^\circ =$ right angle.

Orthogonal Projection of a Point: We call the orthogonal projection of any point on any definite straight line when it signifies the foot of the perpendicular drawn from that point on the definite straight line. Suppose, XY is a definite straight line and P is any point (figure below). We draw the perpendicular PP' from the point P on the straight line XY and P' is the foot of this perpendicular. So, the point P' is the orthogonal of P on the line XY . The orthogonal projection of any point on any definite straight line is a point.

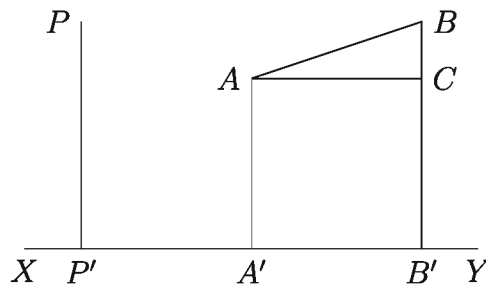

Orthogonal Projection of a Line: Let, the end points of the line segment AB are A and B (figure above). Now the perpendiculars AA' and BB' are drawn

from the points A and B respectively on the line XY . The end points of the perpendiculars AA' and BB' are A' and B' respectively. This line segment $A'B'$ is the orthogonal projection of the line segment AB on XY . Therefore, it is seen that the orthogonal projection is determined by drawing a perpendicular. So, it is said that the line segment $A'B'$ is the orthogonal projection of the line segment AB on XY . In the figure above, if the line segment AB is parallel to XY , then $AB = A'B'$. From this conception, we can say that the perpendicular of the orthogonal projection on any line is a point. In that case, the length of the orthogonal projection is zero.

Note:

1. The foot of the perpendicular drawn from any point on any line is the orthogonal projection of that point.
2. The perpendicular of the orthogonal projection on any line is a point, whose length is zero.
3. Any definite line parallel to the line segment of the orthogonal projection will be equal to that line segment.

Some Important Theorems

We shall now present the logical proof of some important theorems on the basis of the theorem of Pythagoras and by the conception of the orthogonal projection.

Theorem 3. The area of the square drawn on the opposite side of the obtuse angle of an obtuse angled triangle is equal to the total sum of the two squares drawn on the other two sides and product of twice the area of the rectangle included by either of the two other sides and the orthogonal projection of the other side.

Special Nomination: Suppose, in the triangle ABC , $\angle BCA$ is an obtuse angle, AB is the opposite side of the obtuse angle and the sides adjacent to obtuse angle are BC and AC respectively.

CD is the orthogonal projection of the side AC on the extended side BC (figure below). It is to be proved that, $AB^2 = AC^2 + BC^2 + 2 \cdot BC \cdot CD$

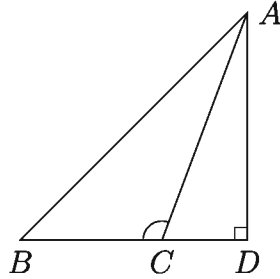

Proof: As CD is the orthogonal projection of the side AC on the extended side BC , $\triangle ABD$ is a right angled triangle and $\angle ADB$ is a right angle.

So, according to the theorem of Pythagoras

$$\begin{aligned} AB^2 &= AD^2 + BD^2 \\ &= AD^2 + (BC + CD)^2 \quad [\because BD = BC + CD] \\ &= AD^2 + BC^2 + CD^2 + 2 \cdot BC \cdot CD \end{aligned}$$

$$\therefore AB^2 = AD^2 + CD^2 + BC^2 + 2 \cdot BC \cdot CD \dots \dots (1)$$

Again $\triangle ADC$ is a right angled triangle and $\angle ADC$ is right angle.

$$\therefore AC^2 = AD^2 + CD^2 \dots \dots (2)$$

From the equation (2), putting the value $AD^2 + CD^2 = AC^2$ in equation (1), we get,

$$AB^2 = AC^2 + BC^2 + 2 \cdot BC \cdot CD \quad [\text{Proved}]$$

Theorem 4. In any triangle, the area of the square drawn on the opposite side of an acute angle is equal to the squares drawn on the other two sides diminished by twice the area of the rectangle included by any one of the other sides and the orthogonal projection of the other side on that side.

Special Nomination: In the triangle $\triangle ABC$, $\angle ACB$ is an acute angle and the opposite side of the acute angle is AB . The other two sides are AC and BC . Suppose, AD is a perpendicular on the side BC (left sided figure below) and the extended side of BC (right sided figure below). So, CD is the orthogonal projection of the side AC on the side BC in the case of both triangles. It is to be proved that $AB^2 = AC^2 + BC^2 - 2 \cdot BC \cdot CD$.

[It is to be noted that here the perpendicular is drawn from A to BC . But similarly, the theorem can be proved by drawing a perpendicular from the point B to AC .]

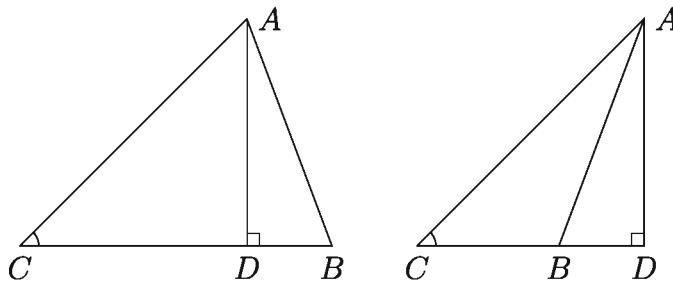

Proof: $\triangle ADB$ is a right angled triangle and $\angle ADB$ is the right angle.

\therefore According to the theorem of Pythagoras, $AB^2 = AD^2 + BD^2$
 $\dots\dots(1)$

In the left sided figure above $BD = BC - CD$.

$$\therefore BD^2 = (BC - CD)^2 = BC^2 + CD^2 - 2 \cdot BC \cdot CD$$

In the right sided figure above $BD = CD - BC$.

$$\therefore BD^2 = (CD - BC)^2 = CD^2 + BC^2 - 2 \cdot CD \cdot BC$$

Therefore, in both figures, $BD^2 = BC^2 + CD^2 - 2 \cdot BC \cdot CD \dots\dots(2)$

Now from equation (1) and (2), we get

$$AB^2 = AD^2 + BC^2 + CD^2 - 2 \cdot BC \cdot CD$$

$$\text{Or, } AB^2 = AD^2 + CD^2 + BC^2 - 2 \cdot BC \cdot CD \dots\dots(3)$$

Again, $\triangle ADC$ is a right angled triangle and $\angle ADC$ is the right angle.

$$\therefore \text{According to the theorem of Pythagoras } AC^2 = AD^2 + CD^2 \dots\dots(4)$$

from equation (3) and (4) we get,

$$AB^2 = AC^2 + BC^2 - 2 \cdot BC \cdot CD \quad [\text{Proved}]$$

Remark:

1. In the case of the right angled triangle, the sides adjacent to the right angle are mutually perpendiculars, so each of their orthogonal projection is zero. If $\angle ACB$ is a right angle then the orthogonal projection of AC on BC is $CD = 0$. So $BC \cdot CD = 0$, therefore $AB^2 = AC^2 + BC^2$
2. Theorem 3 and Theorem 4, are based on Theorem 1. That is why Theorem 3 and Theorem 4 are called extensions of Theorem 1, therefore they can be called extensions of the theorem of Pythagoras.

The decisions made on the basis of the explanation above: in the case of $\triangle ABC$,

- 1) If $\angle ACB$ is an obtuse angle,, $AB^2 > AC^2 + BC^2$ [Theorem 3]
- 2) If $\angle ACB$ is a right angle, $AB^2 = AC^2 + BC^2$ [Theorem 1]
- 3) If $\angle ACB$ is an acute angle, $AB^2 < AC^2 + BC^2$ [Theorem 4]

The following theorem is known as the theorem of Apollonius as this theorem was stated by Apollonius(240- 190 AD). It is established on the basis of the extensions of the theorem of Pythagoras(Theorem 3 and Theorem 4).

Theorem 5 (Theorem of Apollonius). The sum of the areas of the squares drawn on any two sides of a triangle is equal to twice the sum of area of the squares drawn on the median of the third side and on either half of that side.

Special Nomination: AD , Median of triangle $\triangle ABC$, bisects the side BC . It is to be proved that, $AB^2 + AC^2 = 2(AD^2 + BD^2)$.

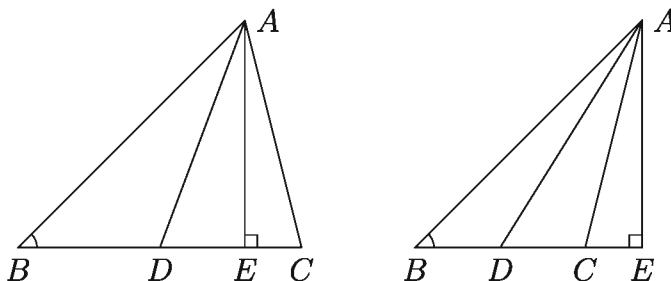

Proof: We draw a perpendicular AE on the side BC (left sided figure above) and on the extended side of BC (right sided figure above). In both figures $\angle ADB$ is the obtuse angle of $\triangle ABD$ and DE is the orthogonal projection of the line AD on the extended BD .

As per the extension of the theorem of Pythagoras in the case of the obtuse angle [Theorem 3] we get,

$$AB^2 = AD^2 + BD^2 + 2 \cdot BD \cdot DE \dots \dots (1)$$

Here, $\angle ADC$ is an acute angle of $\triangle ACD$ and DC (left sided figure above) and DE is the orthogonal projection of the line AD on extended DC (right sided figure above).

As per the extension of the theorem of Pythagoras in the case of the acute angle [Theorem 4] we get,

$$AC^2 = AD^2 + CD^2 - 2 \cdot CD \cdot DE \dots \dots (2)$$

Now adding the equations (1) and (2) we get,

$$\begin{aligned} AB^2 + AC^2 &= 2AD^2 + BD^2 + CD^2 + 2 \cdot BD \cdot DE - 2 \cdot CD \cdot DE \\ &= 2AD^2 + 2BD^2 \quad [\because BD = CD] \end{aligned}$$

$$\therefore AB^2 + AC^2 = 2(AD^2 + BD^2) \quad [\text{Proved}]$$

Determination of the relation between the side of the triangle and the median by the theorem of Apollonius.

Let, length of the sides of BC , CA and AB of the $\triangle ABC$ are a , b and c respectively. AD , BE and CF are the medians drawn on sides BC , CA and AB and their lengths are d , e and f respectively.

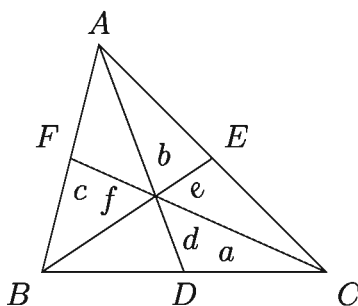

Then from Apollonius's Theorem we get,

$$AB^2 + AC^2 = 2(AD^2 + BD^2)$$

$$\text{Or, } c^2 + b^2 = 2 \left(d^2 + \left(\frac{1}{2}a \right)^2 \right) \quad [\because BD = \frac{1}{2}a]$$

$$\text{Or, } b^2 + c^2 = 2d^2 + 2 \cdot \frac{1}{4}a^2$$

$$\text{Or, } b^2 + c^2 = 2d^2 + \frac{a^2}{2}$$

$$\text{Or, } d^2 = \frac{2(b^2 + c^2) - a^2}{4}$$

Similarly we can get, $e^2 = \frac{2(c^2 + a^2) - b^2}{4}$ and $f^2 = \frac{2(a^2 + b^2) - c^2}{4}$

Therefore we can say that if the lengths of the sides of any triangle are known, the length of the medians can also be known.

$$\text{Again, } d^2 + e^2 + f^2 = \frac{2(b^2 + c^2) - a^2}{4} + \frac{2(c^2 + a^2) - b^2}{4} + \frac{2(a^2 + b^2) - c^2}{4}$$

$$\text{So, } d^2 + e^2 + f^2 = \frac{3}{4}(a^2 + b^2 + c^2)$$

$$\therefore 3(a^2 + b^2 + c^2) = 4(d^2 + e^2 + f^2)$$

So, we can say that in a triangle, thrice the sum of the area of the squares drawn on the three sides is equal to four times the sum of the areas of the squares drawn on the three medians.

If it is a right angled triangle i.e. $\angle ACB$ is a right angle and AB is hypotenuse, then

$$c^2 = a^2 + b^2$$

$$\text{Or, } a^2 + b^2 + c^2 = 2c^2$$

$$\text{Or, } \frac{4}{3}(d^2 + e^2 + f^2) = 2c^2$$

$$\text{Or, } 2(d^2 + e^2 + f^2) = 3c^2$$

Therefore, we can say that twice the sum of the area of the squares drawn on the medians of a right angled triangle is equal to thrice the area of the square drawn on the hypotenuse.

Exercises 3.1

1. In $\triangle ABC$, $\angle B = 60^\circ$. Prove that, $AC^2 = AB^2 + BC^2 - AB \cdot BC$
2. In $\triangle ABC$, $\angle B = 120^\circ$. Prove that, $AC^2 = AB^2 + BC^2 + AB \cdot BC$
3. In $\triangle ABC$, $\angle C = 90^\circ$ and midpoint of BC is D . Prove that,
 $AB^2 = AD^2 + 3BD^2$
4. In $\triangle ABC$, AD is the perpendicular on the side BC , while BE is the perpendicular on the side AC . Prove that, $BC \cdot CD = AC \cdot CE$
5. In $\triangle ABC$, the side BC is trisected at the point P and Q . Prove that,
 $AB^2 + AC^2 = AP^2 + AQ^2 + 4PQ^2$

[Hints: $BP = PQ = QC$; AP is a median of $\triangle ABQ$

$$AB^2 + AQ^2 = 2(BP^2 + AP^2) = 2PQ^2 + 2AP^2.$$

$$AQ \text{ is a median of } \triangle APC. \therefore AP^2 + AC^2 = 2PQ^2 + 2AQ^2.]$$

6. In $\triangle ABC$, $AB = AC$, P is a point on BC . Prove that,
 $AB^2 - AP^2 = BP \cdot PC$ [Hints: Draw a perpendicular AD on BC . Then,
 $AB^2 = BD^2 + AD^2$ and $AP^2 = PD^2 + AD^2$]
7. If the three medians of $\triangle ABC$ meet at G , prove that,
 $AB^2 + BC^2 + AC^2 = 3(GA^2 + GB^2 + GC^2)$
 [Hints: See the corollaries taken in the light of the theorem of Apollonius
 i.e. the relation between the sides and the medians of the triangle needs to
 be used.]

Theorems about Circles and Triangles

In this section some important theorems about circles and triangles will be presented logically. It is mandatory for the students to know the similarity of two triangles before proving the theorems. Similarity of triangles is discussed thoroughly in *Secondary Geometry*. For the convenience of the students, we will briefly recapitulate the similarity of triangles.

Equiangularity: Two polygons having the same number of sides with successive equal angles are said to be **equiangular polygons**.

Similarity: Two polygons having the same number of sides are said to be similar if one can establish a one-one correspondence among their vertices such that

- 1) The corresponding angles are equal and
- 2) The corresponding sides are proportional.

In this case the two polygons are called **similar polygons**.

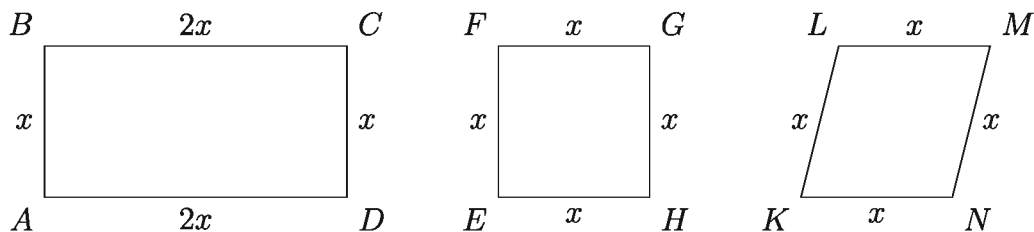

If you take a look at the figure above, you will see that,

- 1) The rectangular $ABCD$ and square $EFGH$ are equiangular but not similar. All of their corresponding angles are right angle, but their corresponding sides are not proportional.

- 2) The square $EFGH$ and rhombus $KLMN$ are not similar, since their corresponding sides are proportional because of any successive matching of their vertex but their corresponding angles are not equal.

However, it is not the same in the the case of two triangles. If one condition of the mentioned two regarding the matching of the angles of the vertices of two triangles is true, the other one will be true as well and the two triangles will become similar. It should be mentioned in this regard that,

- 1) If two triangles are equiangular, each pair of equal angles are called **corresponding angles** and the sides opposite to the corresponding angles are called **corresponding sides**.
- 2) If the three sides of a triangle are proportional to the sides of another triangle, each pair of proportional sides are called **corresponding sides**, and the angles opposite the corresponding sides are called **corresponding angles**.
- 3) In both cases the triangles are described by matching a one-one correspondence among their vertices of the angles. For example, the corresponding angles are $\angle A$ and $\angle D$, $\angle B$ and $\angle E$, $\angle C$ and $\angle F$; the corresponding sides are AB and DE , AC and DF , BC and EF , in case of $\triangle ABC$ and $\triangle DEF$.

Some theorems about the similarity of the two triangle are briefly described below.

Theorem 6. If two triangles are equiangular, their corresponding sides are proportional.

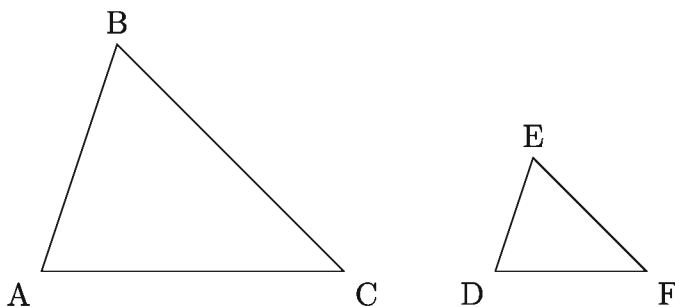

In the figure above, $\triangle ABC$ and $\triangle DEF$ equiangular triangles.

Therefore, since $\angle A = \angle D$, $\angle B = \angle E$ and $\angle C = \angle F$ then $\frac{AB}{DE} = \frac{AC}{DF} = \frac{BC}{EF}$.

That is, the corresponding sides will be proportional.

Corollary 1. if two triangles are equiangular, they will be similar.

Remarks: If the two angles of one triangle are equal to the two angles of the other, the two triangles are equiangular, hence similar. This is because, the sum of the three angles of any triangle is two right angles.

Theorem 7. If the sides of the two triangles are proportional, the opposite angles of the corresponding sides are mutually equal.

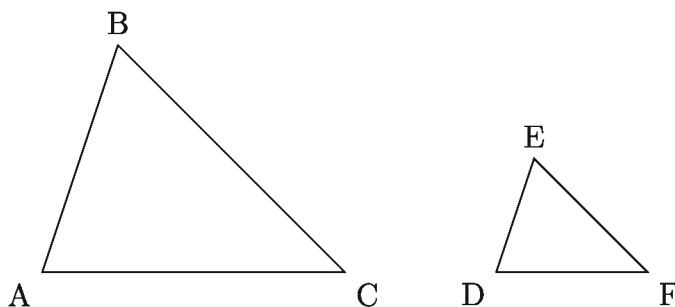

In the figure above, $\triangle ABC$ and $\triangle DEF$ are such that their corresponding sides are proportional i.e., as $\frac{AB}{DE} = \frac{AC}{DF} = \frac{BC}{EF}$, the angles are mutually equal. Therefore, $\angle A = \angle D$, $\angle B = \angle E$ and $\angle C = \angle F$.

Theorem 6 is called the converse proposition of the theorem Theorem 7.

Theorem 8. If one angle of one triangle is equal to an angle of another triangle and the side adjoining the equal angles are proportional, the two triangles will be similar.

In the figure below, $\triangle ABC$ and $\triangle DEF$ are such that $\angle A = \angle D$ and the sides AB , AC and DE , DF adjoining the equal angles are proportional i.e., as $\frac{AB}{DE} = \frac{AC}{DF}$, $\triangle ABC$ and $\triangle DEF$ are similar.

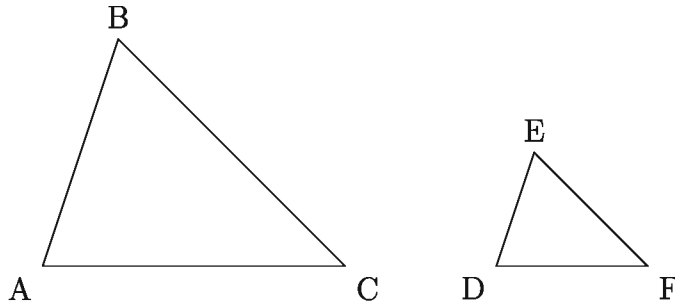

Theorem 9. The ratio of the areas of the two similar triangles is equal to the ratio of the areas of the squares drawn on their two corresponding sides.

In the figure below $\triangle ABC$ and $\triangle DEF$ are similar triangles. BC and EF are the corresponding sides of the two triangles. In this condition, the ratio of the two triangles is equal to the ratio of the squares drawn on the two sides BC and EF . Therefore, $\frac{\triangle ABC}{\triangle DEF} = \frac{BC^2}{EF^2}$. Similarly if AB and DE and AC and DF are the corresponding sides of two triangles, $\frac{\triangle ABC}{\triangle DEF} = \frac{AB^2}{DE^2} = \frac{AC^2}{DF^2}$

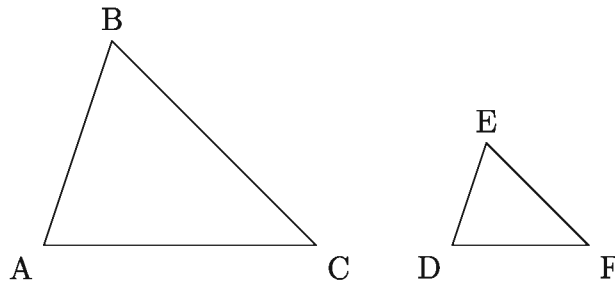

The Circumcenter, Centroid and Orthocenter of a Triangle

Here it should be mentioned that, the distance between the orthocenter and a vertex of a triangle is twice the perpendicular distance from the circumcenter to the opposite side of that vertex.

Circumcenter of a Triangle: The **circumcenter** of a triangle is the point of intersection of two perpendicular bisectors of that triangle. Noted that, the perpendicular bisector of the third side of the triangle would pass through the circumcenter too.

Centroid of a Triangle: The **centroid** of a triangle is the point of intersection of three medians of that triangle. The centroid of a triangle divides each median

into the ratio 2:1.

Orthocenter of a Triangle: The **orthocenter** of a triangle is the point of intersection of the perpendiculars drawn from each vertex to their respective opposite side.

Theorem 10. The circumcenter, the centroid and the orthocenter of any triangle are collinear.

Special Nomination: Suppose, O is the orthocenter, S is the circumcenter and AP is a median of the triangle $\triangle ABC$. The line between orthocenter O and the circumcenter S intersect the median AP at point G . If we join S and P , the line SP is a perpendicular on BC . So, it is enough to prove that the point G is the centroid of $\triangle ABC$.

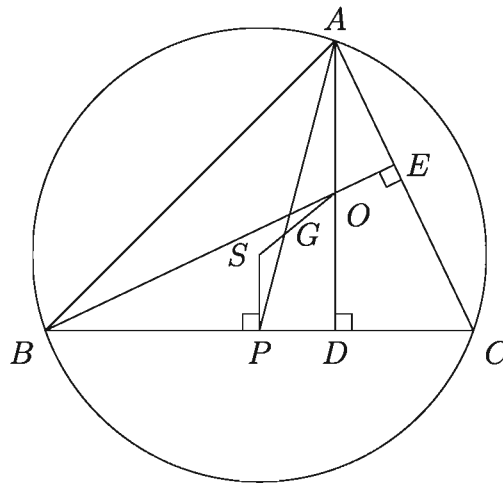

Proof: OA is the distance between the vertex A from the orthocentre O and SP is the distance between the opposite side BC of the vertex A from the circumcentre S of $\triangle ABC$. $\therefore OA = 2SP \dots \dots (1)$

Now since AD and SP both are perpendiculars on BC so $AD \parallel SP$. Now $AD \parallel SP$ and AP is their intersecting line. So $\angle PAD = \angle APS$, as they are both alternate angles. Therefore, $\angle OAG = \angle SPG$.

Now in between $\triangle AGO$ and $\triangle PGS$,

$$\angle AGO = \angle PGS \quad [\text{Vertical opposite angle}]$$

$$\angle OAG = \angle SPG \quad [\text{Alternate angles}]$$

$$\therefore \text{remaining } \angle AOG = \text{remaining } \angle PSG$$

$\therefore \triangle AGO$ and $\triangle PGS$ equiangular.

So, $\frac{AG}{GP} = \frac{OA}{SP}$ therefore, $\frac{AG}{GP} = \frac{2SP}{SP}$ [from the equation (1)]

Therefore, $\frac{AG}{GP} = \frac{2}{1}$ Or, $AG : GP = 2 : 1$

So, the point G divides the median AP into the ratio $2 : 1$.

$\therefore G$ is the centroid of $\triangle ABC$. [Proved]

Note:

- 1) **Nine Point Circle:** The total nine points including the middle points of three sides, feet of the three perpendiculars drawn from each vertex to the opposite side and the middle points of the three line segments joining the orthocenter to the vertices of any triangle lie on one circle. This circle is called the **nine point circle**.
- 2) The center of the nine point circle is the middle point of the line segment joining the orthocenter and the circumcentre.
- 3) The radius of the nine point circle is half of the circumradius of the triangle.

Theorem 11 (The Theorem of Brahmagupta). If any cyclic quadrilateral has perpendicular diagonals, then the perpendicular to a side from the point of intersection of the diagonals always bisects the opposite side.

Special Nomination: $ABCD$ is a quadrilateral inscribed in a circle with perpendicular diagonals AC and BD intersecting at point M . ME is a perpendicular on the side BC from the point M and extended EM intersects the opposite side AD at point F . It is to be proved that $AF = FD$.

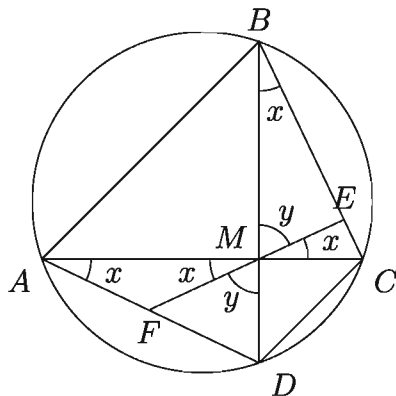

Proof: Because they are inscribed angles that intercept the same arc CD of the circle, $\angle CBD = \angle CAD$

$$\text{So, } \angle CBM = \angle MAF$$

Again, $\angle CBM = \angle CME$ [Both complementary to the $\angle BME$]

$$\text{So, } \angle MAF = \angle FMA$$

Therefore, in $\triangle AFM$, $AF = FM$

Similarly it can be shown that, $\angle FDM = \angle BCM = \angle BME = \angle DMF$

So, in $\triangle DFM$, $FD = FM$

So, $AF = FD$ [Proved]

Theorem 12 (Ptolemy's Theorem). In any cyclic quadrilateral the area of the rectangle contained by the two diagonals is equal to the sum of the area of the two rectangles contained by the two pairs of opposite sides.

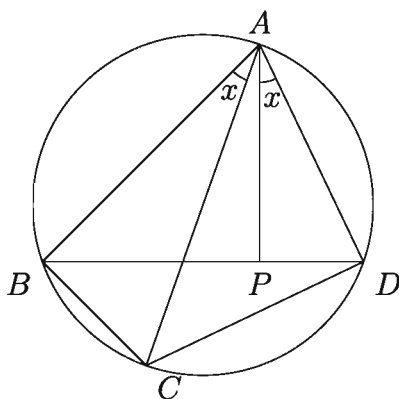

Special Nomination: Suppose $ABCD$ is a cyclic quadrilateral whose two pairs of opposite sides are AB, CD and BC, AD . AC and BD are its diagonals. It is to be proved that, $AC \cdot BD = AB \cdot CD + BC \cdot AD$.

Proof: (Without loss of generality) we can assume that $\angle BAC$ is smaller than $\angle DAC$. Then we draw $\angle DAP$ at point A with line segment AD , making it equal to $\angle BAC$ so that AP intersects the diagonal BD at point P .

According to the construction, $\angle BAC = \angle DAP$.

Adding $\angle CAP$ in both sides, we get

$$\angle BAC + \angle CAP = \angle DAP + \angle CAP \text{ Therefore, } \angle BAP = \angle CAD$$

Now between $\triangle ABP$ and $\triangle ACD$

$\angle BAP = \angle CAD$ and $\angle ABD = \angle ACD$ [angles on the same segment of the circle]

and remaining $\angle APB = \text{remaining} \angle ADC$.

$\therefore \triangle ABP$ and $\triangle ACD$ equiangular.

$$\therefore \frac{BP}{CD} = \frac{AB}{AC}$$

$$\text{So, } AC \cdot BP = AB \cdot CD \dots\dots(1)$$

Again, between $\triangle ABC$ and $\triangle APD$

$\angle BAC = \angle PAD$ [by construction]

$\angle ADP = \angle ACB$ [angles on the same segment of the circle]

and remaining $\angle ABC = \text{remaining} \angle APD$

$\therefore \triangle ABC$ and $\triangle APD$ equiangular.

$$\therefore \frac{AD}{AC} = \frac{PD}{BC}$$

$$\text{Therefore, } AC \cdot PD = BC \cdot AD \dots\dots(2)$$

Now adding equations (1) and (2), we get

$$AC \cdot BP + AC \cdot PD = AB \cdot CD + BC \cdot AD$$

$$\text{Or, } AC(BP + PD) = AB \cdot CD + BC \cdot AD$$

$$\text{But } BP + PD = BD$$

$$\text{So } AC \cdot BD = AB \cdot CD + BC \cdot AD \quad [\text{Proved}]$$

Example 1. In $\triangle PQR$, $\angle PQR = 90^\circ$ and midpoints of the three sides PQ , QR and PR are D , E and F respectively.

- 1) Draw the figure according to the given information and identify the centroid.
- 2) Prove that, $PR^2 = PE^2 + QE^2 + 2RE^2$
- 3) If $QF \perp PR$ prove that, $QF^2 = PF \cdot RF$

Solution:

- 1) In the following figure, as the midpoints of PQ , QR and PR are D , E and F respectively, the medians are PE , QF and DR who intersect at point G .
 \therefore Point G is the centroid.

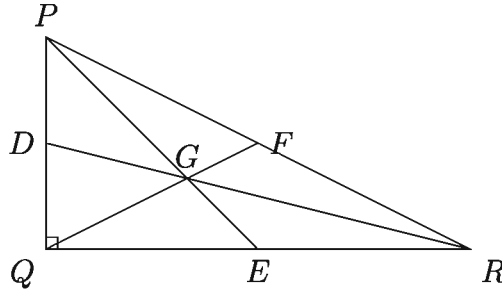

- 2) $\angle PQR = 90^\circ$ and midpoint of QR in $\triangle PQR$ is E . P and E is joined. It is to be proved that, $PR^2 = PE^2 + QE^2 + 2RE^2$.

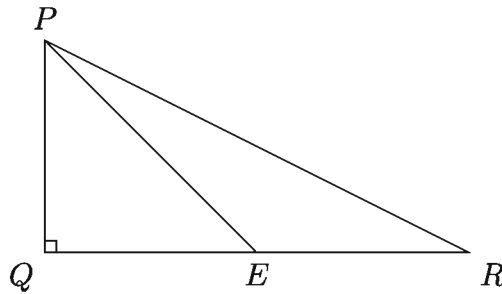

Proof: In $\triangle PQE$. $\angle PQE = 90^\circ$ and PE hypotenuse

$$\therefore PE^2 = PQ^2 + QE^2 \dots\dots (1)$$

Again, in $\triangle PQR$, $\angle PQR = 90^\circ$ and PR hypotenuse

$$\therefore PR^2 = PQ^2 + QR^2$$

$$\text{Or, } PR^2 = PQ^2 + (QE + RE)^2$$

$$\text{Or, } PR^2 = PQ^2 + QE^2 + RE^2 + 2QE \cdot RE$$

$$\text{Or, } PR^2 = PQ^2 + QE^2 + QE^2 + 2RE \cdot RE \quad [\because QE = RE]$$

$$\text{Or, } PR^2 = PE^2 + QE^2 + 2RE^2 \quad [\text{using (1)}]$$

$$\therefore PR^2 = PE^2 + QE^2 + 2RE^2 \quad [\text{Proved}]$$

- 3) In $\triangle PQR$, $\angle PQR = 90^\circ$ and $QF \perp PR$. It is to be proved that, $QF^2 = PF \cdot RF$.

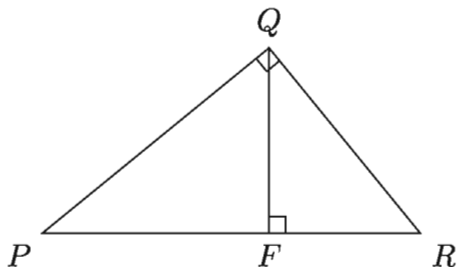

Proof: $\angle PQR = 90^\circ$

$$\therefore \angle PQF + \angle FQR = 90^\circ \dots\dots (1)$$

Again, as $QF \perp PR$, $\angle PFQ = \angle QFR = 90^\circ$

$$\text{In } \triangle PQF, \angle PFQ + \angle PQF + \angle QPF = 180^\circ$$

$$\text{Or, } 90^\circ + \angle PQF + \angle QPF = 180^\circ$$

$$\therefore \angle PQF + \angle QPF = 90^\circ \dots\dots (2)$$

From (1) and (2) we get,

$$\angle PQF + \angle FQR = \angle PQF + \angle QPF$$

$$\therefore \angle FQR = \angle QPF$$

In $\triangle PQF$ and $\triangle QFR$,

$$\angle PFQ = \angle QFR, \angle QPF = \angle FQR$$

$$\text{remaining } \angle PQF = \text{remaining } \angle FRQ$$

$\therefore \triangle PQF$ and $\triangle QFR$ are similar

$$\therefore \frac{PQ}{QR} = \frac{QF}{FR} = \frac{PF}{FQ}$$

$$\text{Hence, } \frac{QF}{RF} = \frac{PF}{QF}$$

$$\text{Or, } QF^2 = PF \cdot RF \text{ [Proved]}$$

Exercise 3.2

1. In the left sided figure below, which is the orthogonal projection of the line segment AB on XY ?

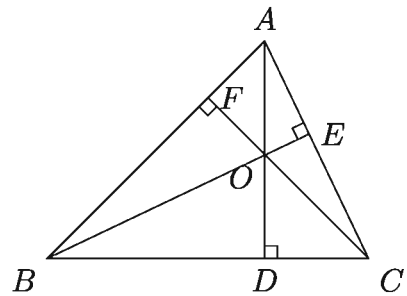
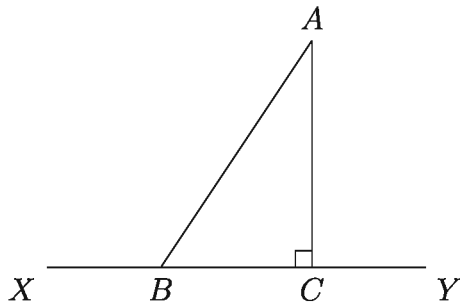
1) AB 2) BC 3) AC 4) XY 

2. In the right sided figure above, which point is the orthocentre of the triangle?

1) D 2) E 3) F 4) O

3. Length of each of the three medians of an equilateral triangle is 3 cm. What is the length of each side?

1) 4.5 cm.

2) 3.46 cm.

3) 4.24 cm.

4) 2.59 cm.

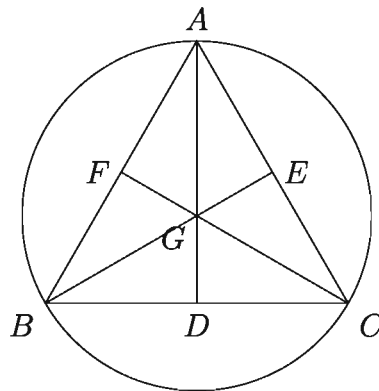

In the figure above, D , E , F are midpoints of BC , AC and AB respectively. In the light of this, answer the questions 4-6:

4. What is the name of the point G ?

1) Orthocenter

3) Centroid

2) Incenter

4) Circumcenter

5. What is the name of the circle drawn using the three vertices of $\triangle ABC$?

1) Circumcircle

3) Excircle

2) Incircle

4) Nine Point Circle

6. Which statement of the followings is consistent with the Theorem of Apollonius applied to the $\triangle ABC$?

$$1) AB^2 + AC^2 = BC^2 \qquad 2) AB^2 + AC^2 = 2(AD^2 + BD^2)$$

$$3) AB^2 + AC^2 = 2(AG^2 + GD^2) \qquad 4) AB^2 + AC^2 = 2(BD^2 + CD^2)$$

7. From any point P lying on the circumcircle of the triangle $\triangle ABC$, perpendiculars PD and PE are drawn on BC and CA respectively. If the line segment ED intersects AB at the point O , then prove that, PO is perpendicular to AB , i.e; $PO \perp AB$

8. $\angle C$ of $\triangle ABC$ is a right angle. If CD is the perpendicular drawn from the vertex C on the hypotenuse, prove that, $CD^2 = AD \cdot BD$

9. AD , BE and CF are the perpendiculars drawn from the vertex of $\triangle ABC$ to the opposite sides and they intersect at the point O . Prove that, $AO \cdot OD = BO \cdot OE = CO \cdot OF$

[Hints: $\triangle BOF$ and $\triangle COE$ are similar. $\therefore BO : CO = OF : OE$.]

10. A semicircle is drawn on the diameter AB . Two of its chords AC and BD intersect at point P . Prove that, $AB^2 = AC \cdot AP + BD \cdot BP$
11. The radius of the circumcircle of an equilateral triangle is 3 cm. Find the length of the side of that triangle.
12. In the isosceles triangle ABC , AD is the perpendicular from vertex A to the base BC . If the circumradius of the triangle is R prove that, $AB^2 = 2R \cdot AD$
13. The bisector of the angle $\angle A$ of the triangle ABC intersects BC at point D and intersects circumcircle ABC at point E . Show that, $AD^2 = AB \cdot AC - BD \cdot DC$
14. In the triangle ABC , BE and CF are perpendiculars on the sides AC and AB respectively. Show that,
 $\triangle ABC : \triangle AEF = AB^2 : AE^2$

15. In $\triangle PQR$, medians PM , QN and RS intersect at the point O .

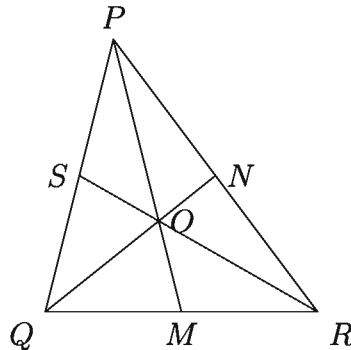

- 1) What is the name of the point O ? In what ratio does point O divide PM ?
 - 2) Establish the relation $PQ^2 + PR^2 = 2(PM^2 + QM^2)$ from $\triangle PQR$.
 - 3) Show that, the sum of squares of the three sides of $\triangle PQR$ is three times the sum of square of distance of the three vertices from point O .
16. In the figure below, S and O are circumcentre and orthocentre of the of the triangle $\triangle ABC$ respectively. AP is a median, $BC = a$, $AC = b$ and $AB = c$.

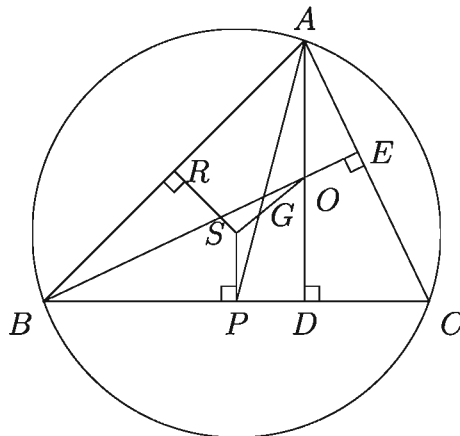

- 1) Establish a relation between OA and SP .
- 2) Show that, S , G , O are collinear.
- 3) If $\angle C$ is an acute angle, establish the equation $a \cdot CD = b \cdot CE$

Chapter 4

Geometric Constructions

The figure drawn by using compass and ruler according to definite conditions is geometric construction. Geometric figures drawn for proving the theorems need not be accurate. But in geometric construction, figure needs to be accurate.

After completing the chapter, the students will be able to –

- ▶ construct the triangles on the basis of given data and information and justify construction;
- ▶ construct the circles on the basis of given data and information and justify construction.

Some constructions Involving Triangles

Construction 1. The base, an angle adjoining the base and height to the triangle are given. Draw the triangle.

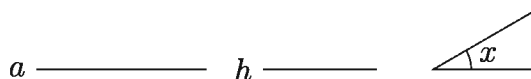

BP on the base BC . Cut $BM = h$ from BP .

Suppose, the base a , the height h and an angle x adjoining the base are given. The triangle needs to be drawn.

Drawing:

Step 1. Cut the part $BC = a$ from any ray BD .

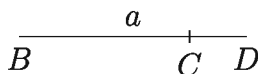

Step 2. Draw at B the perpendicular

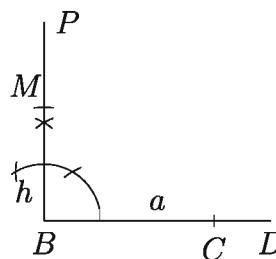

Step 3. Draw through the point M , the line $MN \parallel BC$.

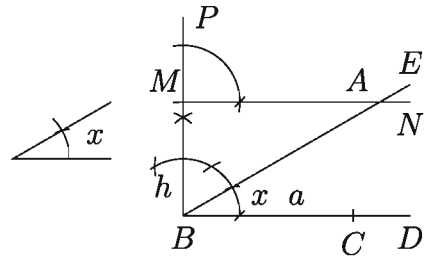
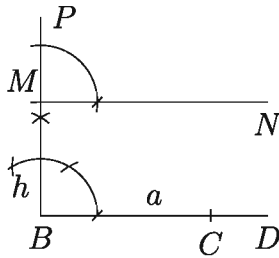

Step 5. Join A and C . Then ABC is the desired triangle.

Step 4. Again construct $\angle CBE$ equal to the given $\angle x$ at the point B . The line segment BE intersects MN at A .

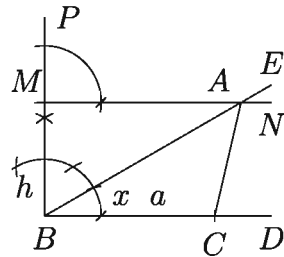

Proof: As $MN \parallel BC$ (As per the construction). \therefore The height of $\triangle ABC$ is $BM = h$. Again $BC = a$ and $\angle ABC = \angle x$. $\therefore \triangle ABC$ is the desired triangle.

Analysis: The base and an angle adjoining the base are given. So we need to cut off a portion from a ray equal to the base and at an end-point we draw an angle equal to the given angle. Then we draw the perpendicular at that end point of the base and cut off a portion equal to the height. The point where the other arm of this angle intersects the line parallel to the base as the given height, is the third vertex of the desired triangle.

Construction 2. The base, the vertical angle and the sum of the lengths of the other two sides of a triangle are given. The triangle needs to be constructed.

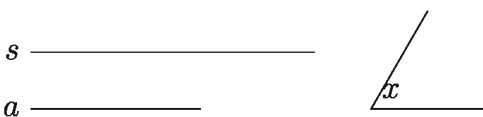

Drawing:

Step 1. Cut the segment $DB = s$ from any ray DE .

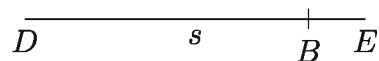

Let a be the base, s be the sum of the other two sides and x be the vertical angle. The triangle needs to be constructed.

Step 2. At D of the line DB , draw

$$\angle BDF = \frac{1}{2}\angle x.$$

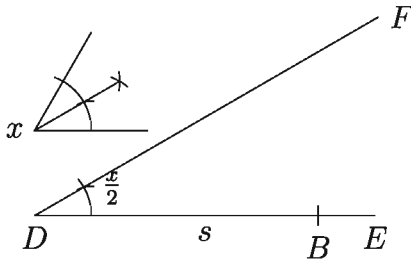

Step 3. Taking B as centre, draw a segment of circle of radius a ; let it intersect DF at C and C' . Join B, C and B, C' .

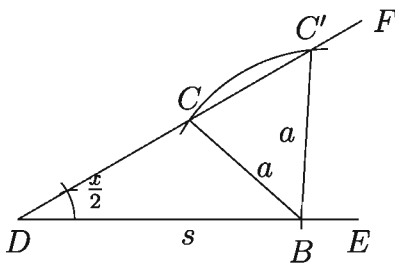

Step 4. At the point C , draw $\angle BDF$ equal to $\angle DCA$ and at C' , draw $\angle BDF$ equal to $\angle DC'A'$. Let CA and $C'A'$ intersect BD at A and A' respectively. Then both the triangles ABC and $A'BC'$ are the required triangle.

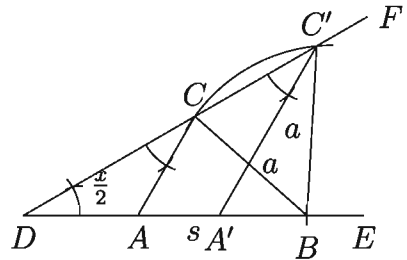

Proof: Since $\angle ACD = \angle ADC = \angle A'C'D = \frac{1}{2}\angle x$ (by construction)

$$\therefore \angle BAC = \angle ADC + \angle ACD = \frac{1}{2}\angle x + \frac{1}{2}\angle x = \angle x$$

$$\therefore \angle BA'C' = \angle A'DC' + \angle A'C'D = \frac{1}{2}\angle x + \frac{1}{2}\angle x = \angle x$$

$$\text{and } AC = AD, A'C' = A'D$$

So, in the triangle ABC ,

$$\angle BAC = \angle x, BC = a \text{ and } CA + AB = DA + AB = DB = s$$

$\therefore \triangle ABC$ is the required triangle.

Again, in the triangle $A'BC'$,

$$\angle BA'C' = \angle x, BC' = a \text{ and } C'A' + A'B = DA' + A'B = DB = s$$

$\therefore \triangle A'BC'$ is the other required triangle.

Construction 3. The base, the vertical angle and the difference of the lengths of the other two sides of the triangle are given. The triangle needs to be constructed.

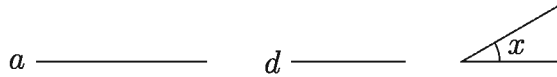

Let a be the base. Given that d is the difference of the other two sides and x is the vertical angle. The triangle needs to be constructed.

Drawing:

Step 1. Cut the segment $BP = d$ from any ray BD .

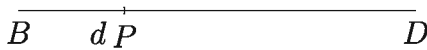

Step 2. At P , draw $\angle DPM$, equal to the half of the supplementary angle of $\angle x$.

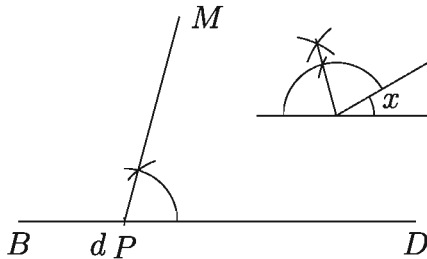

Step 3. Taking B as centre, all are with the radius a of the circle; let the arc equal to the radius intersect the straight line PM at the point

C . Join B and C .

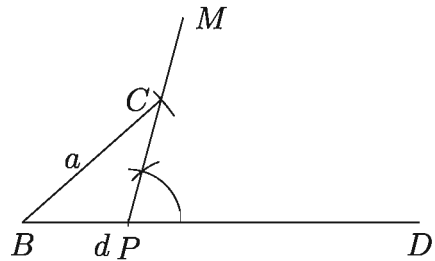

Step 4. Again, at the point C , draw $\angle DPC = \angle PCA$ so that the line segment CA intersect BD at A . Then ABC is the required triangle.

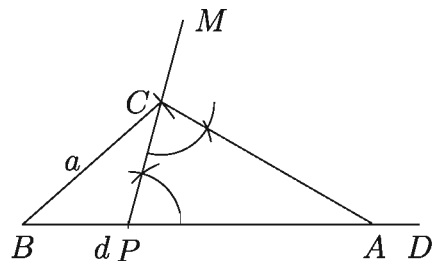

Proof: $\angle APC = \angle ACP$

$$\therefore AP = AC$$

$$\therefore AB - AC = AB - AP = d$$

Again $\angle APC = \angle ACP$ is half of the supplementary angle of $\angle x$.

$$\therefore \angle APC + \angle ACP = \text{Supplementary of } \angle x = \text{external } \angle CAD = \text{supplementary angle of } \angle CAB$$

$\therefore \angle A = \angle CAB = \angle x$

$\therefore ABC$ is the required triangle.

Construction 4. The height, the median on the base and an angle adjoining to the base of the triangle are given. The triangle needs to be constructed.

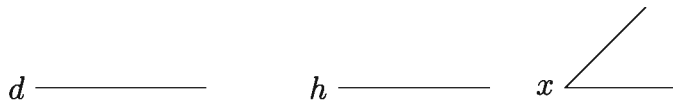

Let h be the height, d be the median on the base and $\angle x$ be an angle adjoining to the base of the triangle. The triangle needs to be constructed.

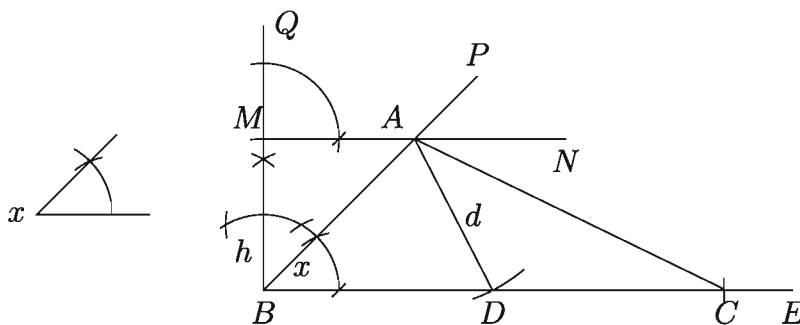

Drawing:

Step 1. Draw BE and draw $\angle EBP$ equal to $\angle x$ at B .

Step 2. At the point B , draw BQ perpendicular on the line BE .

Step 3. From BQ , cut BM equal to the height h .

Step 4. At the point M , draw the line $MN \parallel BE$ which intersects BP at the point A .

Step 5. Taking A as centre, draw an arc with the radius equal to the median d ; let the arc intersect BE at the point D .

Step 6. From BE , cut the segment $DC = BD$. Join A and C .

Then $\triangle ABC$ is the required triangle.

Proof: $BD = DC \therefore D$ is the middle point of BC .

Join A, D . $\therefore AD = d =$ the median drawn on the base, i.e., the base BC .

MN and BE are parallel line. Therefore the height of the $\triangle ABC$ is $BM = h$.

Again, $\angle ABC = \angle x =$ adjacent to the given length of the median.

$\therefore ABC$ is the required triangle.

Remark: We can get two triangle in many cases depending on $\angle x$. Besides, the triangle can not be drawn if the length of the median is lees then height.

Example 1. Given that the length of the base of a triangle is 5 cm., angle adjoining the base is 60° and the sum of the lengths of the two other sides is 7 cm. Construct the triangle.

Solution: It is given that the base $BC = 5$ cm., the sum of the lengths of the two other sides $AB + AC = 7$ cm. and $\angle ABC = 60^\circ$. Construct $\triangle ABC$.

Step 1. From any ray BX , cut off $BC = 5$ cm.

Step 2. Draw $\angle XBY = 60^\circ$.

Step 3. From the ray BY , cut $BD = 7$ cm.

Step 4. Join C, D .

Step 5. Draw the perpendicular bisector of CD , let it intersect BD at the point A .

Step 6. Join A, C , Then ABC is the required triangle.

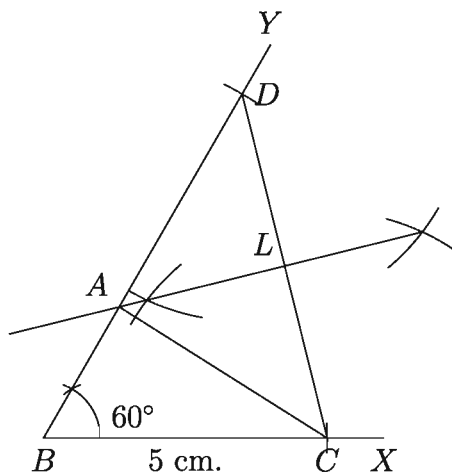

Note: Since AL is the perpendicular bisector of CD , $AD = AC$.

Then $BD = BA + AD = BA + AC = 7$ cm.

Example 2. The length of the base of a triangle is 7.5 cm., an angle adjoining the base is 45° and the difference of the lengths of the other two sides is 2.5cm.

Construct the triangle.

Solution: Given that the base $BC = 7.5$ cm., difference of the other two sides $AB - AC$ or $AC - AB = 2.5$ cm. and the angle adjoining the base 45° . Construct the triangle. Here we will see the steps in the Construction of $AB - AC = 2.5$ cm. [Draw the triangle taking $AC - AB = 2.5$ cm.]

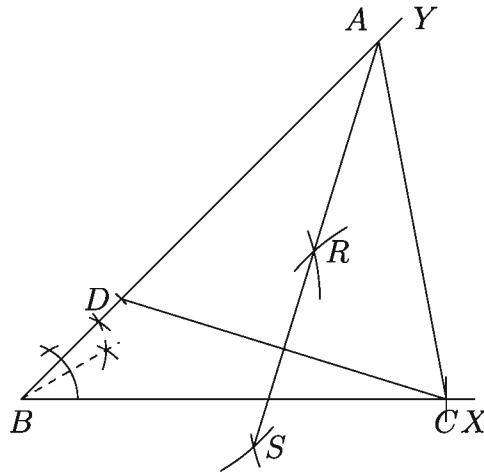

Step 1. From any ray BX cut $BC = 7.5$ cm.

Step 2. Draw $\angle YBC = 45^\circ$.

Step 3. From the ray BY , cut $BD = 2.5$ cm.

Step 4. Join C, D .

Step 5. Draw the perpendicular bisector RS of CD ; let it intersect BY at the point A .

Step 6. Join A and C . Then ABC is the required triangle.

Activity:

- 1) The perimeter and the two angles adjoining the base of a triangle are given. Draw the triangle.
- 2) The base $BC = 4.6$ cm., $\angle B = 45^\circ$ and $AB + CA = 8.2$ cm. of a triangle are given. Draw the triangle.
- 3) In a right angled triangle, the length of the sides are 3 cm. and 4 cm. respectively are given. Determining the hypotenuse, draw the triangle.

- 4) The base $BC = 4.5$ cm., $\angle B = 45^\circ$ and $AB - AC = 2.5$ cm. of a triangle $\triangle ABC$ are given. Draw the triangle $\triangle ABC$.
- 5) The perimeter of $\triangle ABC$ is 12cm., $\angle B = 60^\circ$ and $\angle C = 45^\circ$ are given. Draw the triangle $\triangle ABC$.

Some Constructions Involving Circles

Construction 5. Draw such a circle which passes through two definite points and whose centre lies on a definite straight line.

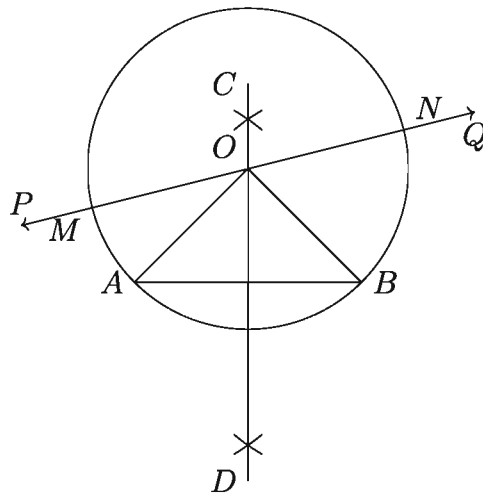

A and B are the two fixed points, PQ is a fixed straight line. Construct such a circle which passes through the points A and B and whose centre lies on the straight line PQ .

Drawing:

Step 1. Join A, B .

Step 2. Construct the perpendicular bisector CD of line segment AB .

Step 3. The line segment CD intersects the line PQ at the point O .

Step 4. Taking O as centre draw the circle of radius OA or OB , $ABNM$ is the desired circle.

Proof: The line segment CD is perpendicular bisector of AB . Therefore, any point on CD is of equal distance from A and B . By construction, the point O lies on CD and PQ . Again, since OA and OB are equal so the circle drawn at the

Forma-13, Higher Mathe Class-9-10

centre O with the radius OA or OB will pass through the points A and B and the centre O will lie on the line segment PQ . \therefore the circle drawn with O as centre and OA or OB is the required circle.

Construction 6. With the radius equal to a definite line segment, construct a circle which passes through two definite points.

A and B are the definite points and r is the length of the definite line segments. Construct such a circle which passes through A and B and whose radius is equal to r .

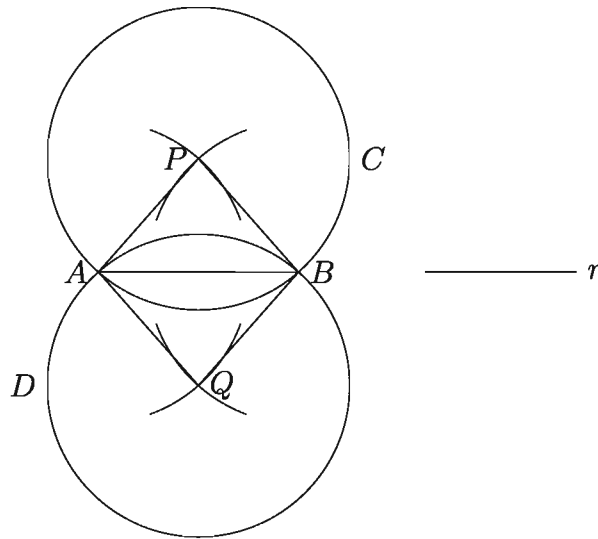

Drawing:

Step 1. Join A and B .

Step 2. Draw two segments of the two circles of radius by centering A and B and taking r as radius on both sides of the line AB . The two pairs of segments of the two circles intersect at P and Q on the two sides of the line AB respectively.

Step 3. Taking P as centre and PA as radius, draw the circle ABC .

Step 4. Again taking Q as centre and QA as radius, draw the circle ABD .

Step 5. Then each of ABC and ABD is the required circle.

Proof: $PA = PB = r$. \therefore The drawn circle ABC with centre P and radius PA or PB that passes through the points A and B and its radius is $PA = r$.

Again $QA = QB = r$. \therefore The drawn circle ABD with centre Q and radius QA or

QB passes through the points A and B and its radius is $QA = r$.

\therefore Each of the two circles ABC and ABD is the required circle.

Construction 7. Construct a circle which touches a definite point of a definite circle and passes through a definite point outside the circle

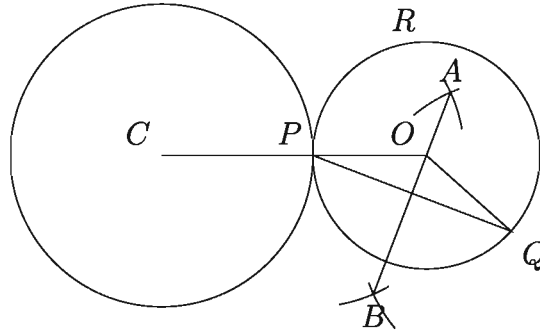

Let a circle be given with centre C , P be a definite point on that circle and Q be a definite point outside that circle. Draw a circle which touches the circle at P and passes through the point Q .

Drawing:

Step 1. Join P, Q .

Step 2. Draw the perpendicular bisector AB of PQ .

Step 3. Join C, P .

Step 4. Extended line segment CP intersects AB at the point O .

Step 5. Taking O as centre, draw the circle with radius equal to OP . The resulting circle PQR is the required circle.

Proof: Join O, Q . The line segment AB or the line segment OB is the perpendicular bisector of PQ . $\therefore OP = OQ$.

So the circle of radius OP and centre O will pass through Q .

Again the point P lies on the given circle and on the constructed circle and also the line joining the centres of the two circles. i.e. the two circles intersect at the point P . So the two circles touch each other at P .

Therefore, the circle drawn with O as the centre and OP as the radius is the required circle.

Construction 8. Construct a circle which touches a definite point on a definite straight line and passes through a point.

Suppose A is a definite point on the straight line AB and P be a point not lying on the line AB . To draw a circle which touches the line AB at A passes through the point P .

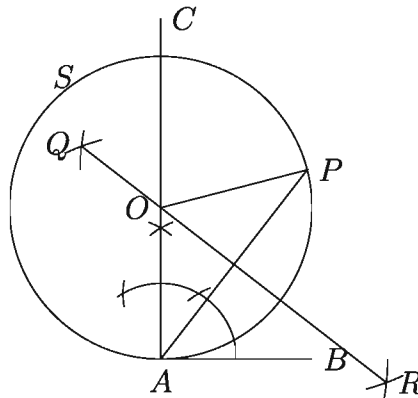

Drawing:

Step 1. Draw the perpendicular AC at the point A on the line AB .

Step 2. Join P, A and construct its perpendicular bisector QR .

Step 3. The lines QR and AC intersect at O .

Step 4. Taking O as centre draw the circle APS with radius OA . Then APS is the required circle.

Proof: Join O, P . The point O lies on QR that is perpendicular bisector of AP .

$\therefore OA = OP$.

\therefore The circle with centre O and radius OA passes through the points P .

Again, OA passing through A is a perpendicular to the line AB .

\therefore So the circle touches line AB at the point A .

\therefore Taking O as the centre and OA as the radius, the drawn circle is the required circle.

Analysis: Since the circle is required to touch a definite line at a definite point, so, that line has to be tangent to the circle at that definite point and this tangent has to be the diameter of the circle. Since the definite point on the line and the definite external point both are required to lie on the circle, the perpendicular

bisector of the line segment joining the two points will pass through the centre. So the centre is the point of intersection of this bisector with the perpendicular erected at the point given on the definite line.

Example 3. Given, a point at a distance of 5 cm. from the centre of a circle of radius 2 cm. Determine the distance of the two tangents.

Solution: Draw a circle with the centre at O and 2 cm. Fix a point P at a distance of 5 cm. from O . We need to construct the two tangents to the circle for determining their lengths

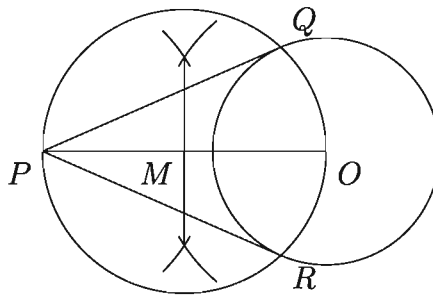

Step 1. Bisect the line OP . Let M be the bisector point.

Step 2. Draw the circle with centre at M and the radius OM that intersects the circle with the centre O at the points Q and R .

Step 3. Join P, Q and P, R . Then PQ and PR are the two required tangents.

Now measuring PQ and PR we find $PQ = PR = 4.6$ cm.

Activity:

- 1) Drawing the incircle of a triangle whose sides have lengths 5 cm., 12 cm. and 13 cm., measure the length of its radius.
- 2) Drawing the circumcircle of a triangle whose sides have lengths 6.5 cm., 7 cm. and 7.5 cm., measure the length of its radius.

Exercises 4

1. If $\angle x = 60^\circ$, what is the measurement of the half of the supplementary angle of $\angle x$?

- 1) 30° 2) 60° 3) 120° 4) 180°
2. 3.5 cm., 4.5 cm. and 5.5 cm. are the radius of the three circles that touches each other externally, then what is the perimeter of the triangle formed by the the three centres of the circles?
- 1) 54 2) 40.5 3) 27 4) 13

Answer the questions 3 and 4 in according to the following figure-

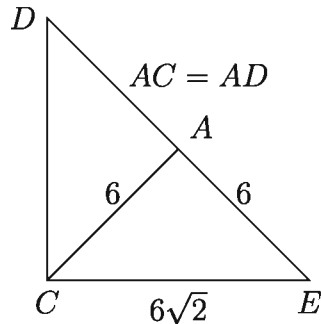

3. What is the value of $\angle ADC$?
- 1) 30° 2) 45° 3) 60° 4) 75°
4. What is the ratio of the area $\triangle ADC$ and $\triangle AEC$?
- 1) 2 : 1 2) 1 : 1 3) 1 : 2 4) $1 : \sqrt{2}$
5. Two angles and the difference of the lengths of their opposite sides of any triangle are given, draw the triangle.
6. The base, the difference of the angles adjoining the base and the sum of the other two sides are given, draw the triangle.
7. The base, the vertical angle and the sum of the other two angles are given. Draw the triangle.
8. The base, the vertical angle and the difference of the other two angles are given. Draw the triangle.
9. The length of the hypotenuse and the sum of the other two sides of a right angle triangle are given. Draw the triangle.
10. A base adjacent angle, height and the sum of the other two sides of a triangle are given. Draw the triangle.
11. (i) Given the length of the hypotenuse and the difference of the lengths of the other two sides are given. Draw the triangle.

- (ii) Three medians of a triangle are given. Draw the triangle.
12. Draw a circle which touches a definite straight line at a definite point and another circle.
 13. Draw a circle which touches a definite straight line at a definite point and another circle at any point.
 14. Draw a circle which touches a given straight line at some point and also touches a given circle at a certain point on it.
 15. Draw three circles of such different radii that they touch each other externally.
 16. P is any point on a chord AB of a circle with the centre O . Draw a chord CD through P such that $CP^2 = AP \cdot PB$.
 17. In an isosceles triangle, the base has the length 5 cm. and the equal sides have the length 6 cm.
 - 1) Draw the triangle.
 - 2) Draw the circumcircle of the triangle and measure its radius.
 - 3) Draw a circle which touches a point P of the circle whose radius is equal to the circumradius of the previous triangle and which passes through the point Q outside that circle.
 18. The radius of a circle is 3 cm. with the centre O and T is a point at a distance of 5 cm. from O .
 - 1) Construct the figure in accordance with the above information.
 - 2) Draw two tangents of the circle from T . (Construction and description is must)
 - 3) Determine the sum of the length of the two tangents by using Pythagoras theorem.

Chapter 5

Equation

Equations are used to describe various mathematical problems. For example, someone buys some shirts at the price of Tk. 200 each and some pants at Tk. 400 each, which costs him a total of Tk. 1500. We can describe this information by the equation $200s + 400p = 1500$ or, $2s + 4p = 15$, where s = number of shirts and p = number of pants.

$2s + 4p = 15$ is an equation, where s and p are unknown variables. Variables s and p have specific domains and equations are used to find the values of unknown variables from their corresponding domains.

At the end of this chapter, the students will be able to –

- ▶ solve quadratic equations ($ax^2 + bx + c = 0$);
- ▶ identify the equations involving square roots;
- ▶ solve the equations involving square roots;
- ▶ explain indicial equations;
- ▶ solve indicial equations;
- ▶ solve system of linear and quadratic equations of two variables;
- ▶ express practical problems in linear and quadratic equations of two variables and solve them;
- ▶ solve system of indicial equations of two variables;
- ▶ solve quadratic equations ($ax^2 + bx + c = 0$) graphically.

Quadratic equations of one variable and their solutions

We know, values of variables for which both sides of an equation are equal, are called roots of that equation and these values satisfy the equation.

Linear and quadratic equations of one variable and linear equations of two variables have been discussed in details in the Secondary Algebra Book. A quadratic equation of one variable e.g, $ax^2 + bx + c = 0$ can be solved easily after factorizing the left hand side of the equation if the roots are rational. But all expressions cannot be factorized easily. That is why the following procedure is used to solve the quadratic equations of any form.

Now we solve the 2nd quadratic equation.

$$ax^2 + bx + c = 0$$

$$\text{or, } a^2x^2 + abx + ac = 0 \text{ [Multiplying both sides by } a\text{]}$$

$$\text{or, } (ax)^2 + 2(ax)\frac{b}{2} + \left(\frac{b}{2}\right)^2 - \left(\frac{b}{2}\right)^2 + ac = 0$$

$$\text{or, } \left(ax + \frac{b}{2}\right)^2 = \frac{b^2}{4} - ac$$

$$\text{or, } \left(ax + \frac{b}{2}\right)^2 = \frac{b^2 - 4ac}{4}$$

$$\text{or, } ax + \frac{b}{2} = \pm \frac{\sqrt{b^2 - 4ac}}{2}$$

$$\text{or, } ax = -\frac{b}{2} \pm \frac{\sqrt{b^2 - 4ac}}{2}$$

$$\text{or, } x = \frac{-b \pm \sqrt{b^2 - 4ac}}{2a} \dots\dots (1)$$

Therefore, the two values of x are:

$$x_1 = \frac{-b + \sqrt{b^2 - 4ac}}{2a} \dots\dots (2) \text{ and } x_2 = \frac{-b - \sqrt{b^2 - 4ac}}{2a} \dots\dots (3)$$

In equation (1) above, $b^2 - 4ac$ is called the **Discriminant** of the quadratic equation, because it determines the state and nature of the roots of the equation.

Variations and nature of the roots of a quadratic equation depending on the conditions of the discriminant

Let a , b , c are rational number. Then,

- 1) If $b^2 - 4ac > 0$ and is a perfect square, then the two roots of the equation are real, unequal and rational.

- 2) If $b^2 - 4ac > 0$ but is not a perfect square, then the two roots of the equation are real, unequal and irrational.
- 3) If $b^2 - 4ac = 0$ hence the roots of the equation are real and equal. In this case, $x = -\frac{b}{2a}$
- 4) If $b^2 - 4ac < 0$ then the roots of the equation are not real. In this case, the two roots are always conjugate complex or imaginary to each other.

Example 1. Solve $x^2 - 5x + 6 = 0$.

Solution: Comparing the given equation with $ax^2 + bx + c = 0$, we get $a = 1$, $b = -5$ and $c = 6$, So the solutions of the equation are:

$$x = \frac{-(-5) \pm \sqrt{(-5)^2 - 4 \cdot 1 \cdot 6}}{2 \cdot 1} = \frac{5 \pm \sqrt{25 - 24}}{2} = \frac{5 \pm \sqrt{1}}{2} = \frac{5 \pm 1}{2}$$

$$\text{or, } x = \frac{5+1}{2}, \frac{5-1}{2}$$

That is $x_1 = 3$, $x_2 = 2$

Example 2. Solve $x^2 - 6x + 9 = 0$.

Solution: A comparison with $ax^2 + bx + c = 0$ gives $a = 1$, $b = -6$ and $c = 9$, Hence we obtain,

$$x = \frac{-(-6) \pm \sqrt{(-6)^2 - 4 \cdot 1 \cdot 9}}{2 \cdot 1} = \frac{6 \pm \sqrt{36 - 36}}{2} = \frac{6 \pm 0}{2}$$

That is $x_1 = 3$, $x_2 = 3$

Example 3. Solve $x^2 - 2x - 2 = 0$.

Solution: After comparing this equation with the standard quadratic equation $ax^2 + bx + c = 0$ we can write $a = 1$, $b = -2$ and $c = -2$.

Therefore, the two roots are:

$$x = \frac{2 \pm \sqrt{(-2)^2 - 4 \cdot 1 \cdot (-2)}}{2 \cdot 1} = \frac{2 \pm \sqrt{4+8}}{2} = \frac{2 \pm \sqrt{12}}{2}$$

$$\text{or, } x = \frac{2 \pm 2\sqrt{3}}{2} = \frac{2(1 \pm \sqrt{3})}{2} = 1 \pm \sqrt{3}$$

i.e. $x_1 = 1 + \sqrt{3}$, $x_2 = 1 - \sqrt{3}$,

It is noticed here that though $x^2 - 2x - 2$ cannot be factorized with rational numbers, yet it has been possible to solve the equation by this method.

Example 4. Solve $3 - 4x - x^2$

Solution: Comparing the equation with the standard quadratic equation $ax^2 + bx + c = 0$ we get $a = -1$, $b = -4$, $c = 3$,

\therefore the two roots are:

$$x = \frac{-(-4) \pm \sqrt{(-4)^2 - 4 \cdot (-1) \cdot 3}}{2 \cdot (-1)} = \frac{4 \pm \sqrt{16 + 12}}{-2} = \frac{4 \pm \sqrt{28}}{-2}$$

$$= \frac{4 \pm 2\sqrt{7}}{-2} \text{ or, } x = -(2 \pm \sqrt{7})$$

i.e. $x_1 = -2 - \sqrt{7}$, $-2 + \sqrt{7}$,

Activity: Use the formulae (2) and (3) mentioned above to find the values of x_1 and x_2 from $ax^2 + bx + c = 0$, when

1) $b = 0$	2) $c = 0$	3) $b = c = 0$
4) $a = 1$	5) $a = 1, b = c = 2p$	

Exercise 5.1

Use formula to solve the following equations:

- | | | |
|------------------------|------------------------|------------------------|
| 1. $2x^2 + 9x + 9 = 0$ | 2. $3 - 4x - 2x^2 = 0$ | 3. $4x - 1 - x^2 = 0$ |
| 4. $2x^2 - 5x - 1 = 0$ | 5. $3x^2 + 7x + 1 = 0$ | 6. $2 - 3x^2 + 9x = 0$ |
| 7. $x^2 - 8x + 16 = 0$ | 8. $2x^2 + 7x - 1 = 0$ | 9. $7x - 2 - 3x^2 = 0$ |

Equations involving radicals

In an equation, the quantities with a variable involving a square root sign are freed from the square root sign by squaring and a new equation is obtained. All the roots of the equation thus obtained do not satisfy the given equation. These are extraneous roots. Therefore, the roots of the equation involving the radical sign are to be tested to know whether they satisfy the given equation or not. After test, those who satisfy the given equation are the roots of the equation. Some examples are given below:

Example 5. Solve: $\sqrt{8x + 9} - \sqrt{2x + 15} = \sqrt{2x - 6}$

Solution: $\sqrt{8x + 9} - \sqrt{2x + 15} = \sqrt{2x - 6}$

$$\text{or, } \sqrt{2x+15} + \sqrt{2x-6} = \sqrt{8x+9}$$

$$\text{or, } 2x+15+2x-6+2\sqrt{2x+15}\sqrt{2x-6} = 8x+9 \text{ [squaring]}$$

$$\text{or, } \sqrt{2x+15}\sqrt{2x-6} = 2x$$

$$\text{or, } (2x+15)(2x-6) = 4x^2 \text{ [again squaring]}$$

$$\text{or, } 4x^2 + 18x - 90 = 4x^2$$

$$\text{or, } 18x = 90$$

$$\therefore x = 5$$

Verification: For $x = 5$, left hand side = $\sqrt{49} - \sqrt{25} = 7 - 5 = 2$ and right hand side = $\sqrt{4} = 2$

\therefore Required solution $x = 5$.

Activity: Taking $p = \sqrt{\frac{x}{x+16}}$ solve $\sqrt{\frac{x}{x+16}} + \sqrt{\frac{x+16}{x}} = \frac{25}{12}$ and then verify the result.

Example 6. Solve: $\sqrt{2x+8} - 2\sqrt{x+5} + 2 = 0$

Solution: $\sqrt{2x+8} = 2\sqrt{x+5} - 2$

$$\text{or, } 2x+8 = 4(x+5) + 4 - 8\sqrt{x+5} \text{ [squaring]}$$

$$\text{or, } 8\sqrt{x+5} = 4x+20+4-2x-8$$

$$\text{or, } 8\sqrt{x+5} = 2x+16 = 2(x+8)$$

$$\text{or, } 4\sqrt{x+5} = x+8$$

$$\text{or, } 16(x+5) = x^2 + 16x + 64 \text{ [squaring]}$$

$$\text{or, } 16x+80 = x^2 + 16x + 64$$

$$\text{or, } 16 = x^2$$

$$\therefore x = \pm\sqrt{16} = \pm 4$$

Verification: For $x = 4$ left hand side = $\sqrt{16} - 2\sqrt{9} + 2 = 4 - 2 \times 3 + 2 = 0 =$ right hand side

For $x = -4$, left hand side = $\sqrt{-8+8} - 2\sqrt{-4+5} + 2 = 0 - 2 \times 1 + 2 = 0 =$ right hand side

\therefore Required solution $x = 4, -4$

Example 7. Solve: $\sqrt{2x+9} - \sqrt{x-4} = \sqrt{x+1}$

Solution: $\sqrt{2x+9} - \sqrt{x-4} = \sqrt{x+1}$

or, $2x+9+x-4-2\sqrt{2x+9}\sqrt{x-4} = x+1$ [squaring]

or, $2x+4-2\sqrt{2x+9}\sqrt{x-4} = 0$

or, $\sqrt{2x+9}\sqrt{x-4} = x+2$

or, $(2x+9)(x-4) = x^2+4x+4$ [squaring]

or, $2x^2+x-36 = x^2+4x+4$

or, $x^2-3x-40 = 0$

or, $(x-8)(x+5) = 0$

$\therefore x = 8$ or $x = -5$

Verification: For $x = 8$, left hand side = $5 - 2 = 3$ and right hand side = 3

$\therefore x = 8$ is a root of the given equation.

$x = -5$ is not acceptable. Because putting $x = -5$, each term becomes the square root of a negative number which is not defined.

\therefore Required solution $x = 8$

Remark: $x = -5$ is not acceptable even when we determine the roots in complex number.

Example 8. Solve: $\sqrt{(x-1)(x-2)} + \sqrt{(x-3)(x-4)} = \sqrt{2}$

Solution: $\sqrt{(x-1)(x-2)} + \sqrt{(x-3)(x-4)} = \sqrt{2}$

or, $\sqrt{x^2-3x+2} - \sqrt{2} = -\sqrt{x^2-7x+12}$

or, $x^2-3x+2-2\sqrt{2}\sqrt{x^2-3x+2}+2 = x^2-7x+12$ [squaring]

or, $\sqrt{2x^2-6x+4} = 2x-4$

or, $2x^2-6x+4 = (2x-4)^2 = 4x^2-16x+16$ [squaring]

or, $x^2-5x+6 = 0$

or, $(x-2)(x-3) = 0$

$\therefore x = 2$ or $x = 3$,

Verification: For $x = 2$, left hand side = $\sqrt{2} =$ right hand side

For $x = 3$, left hand side = $\sqrt{2} =$ right hand side

∴ Required solution $x = 2, 3$.

Example 9. Solve: $\sqrt{x^2 - 6x + 15} - \sqrt{x^2 - 6x + 13} = \sqrt{10} - \sqrt{8}$

Solution: $\sqrt{x^2 - 6x + 15} - \sqrt{x^2 - 6x + 13} = \sqrt{10} - \sqrt{8}$

Now, writing $x^2 - 6x + 13 = y$, we get the equation as

$$\sqrt{y+2} - \sqrt{y} = \sqrt{10} - \sqrt{8}$$

$$\text{or, } \sqrt{y+2} + \sqrt{8} = \sqrt{y} + \sqrt{10}$$

$$\text{or, } y + 2 + 8 + 2\sqrt{8y+16} = y + 10 + 2\sqrt{10y} \text{ [squaring]}$$

$$\text{or, } \sqrt{8y+16} = \sqrt{10y}$$

$$\text{or, } 8y + 16 = 10y \text{ [squaring]}$$

$$\text{or, } 2y = 16 \text{ or, } y = 8$$

$$\text{or, } x^2 - 6x + 13 = 8 \text{ [putting the value of } y]$$

$$\text{or, } x^2 - 6x + 5 = 0 \text{ or, } (x-1)(x-5) = 0$$

∴ $x = 1$ or 5 ,

Verification: For $x = 1$, left hand side = $\sqrt{10} - \sqrt{8} =$ right hand side

For $x = 5$, left hand side = $\sqrt{10} - \sqrt{8} =$ right hand side

∴ Required solution $x = 1, 5$

Example 10. Solve: $(1+x)^{\frac{1}{3}} + (1-x)^{\frac{1}{3}} = 2^{\frac{1}{3}}$

Solution: $(1+x)^{\frac{1}{3}} + (1-x)^{\frac{1}{3}} = 2^{\frac{1}{3}}$

$$\text{or, } 1+x + 1-x + 3 \cdot (1+x)^{\frac{1}{3}}(1-x)^{\frac{1}{3}} \{(1+x)^{\frac{1}{3}} + (1-x)^{\frac{1}{3}}\} = 2 \text{ [cubing]}$$

$$\text{or, } 2 + 3 \cdot (1+x)^{\frac{1}{3}}(1-x)^{\frac{1}{3}} \cdot 2^{\frac{1}{3}} = 2$$

$$\text{or, } 3 \cdot 2^{\frac{1}{3}} \cdot (1+x)^{\frac{1}{3}} \cdot (1-x)^{\frac{1}{3}} = 0$$

$$\text{or, } (1+x)^{\frac{1}{3}}(1-x)^{\frac{1}{3}} = 0$$

$$\text{or, } (1+x)(1-x) = 0 \text{ [again cubing]}$$

$x = 1$ and $x = -1$ both the roots satisfy the equation.

∴ Required solution $x = \pm 1$

Exercise 5.2

Solve:

1. $\sqrt{x-4} + 2 = \sqrt{x+12}$

3. $\sqrt{2x+7} + \sqrt{3x-18} = \sqrt{7x+1}$

5. $\sqrt{11x-6} = \sqrt{4x+5} + \sqrt{x-1}$

7. $\sqrt{x^2-6x+9} - \sqrt{x^2-6x+6} = 1$

9. $6\sqrt{\frac{2x}{x-1}} + 5\sqrt{\frac{x-1}{2x}} = 13$

2. $\sqrt{11x-6} = \sqrt{4x+5} - \sqrt{x-1}$

4. $\sqrt{x+4} + \sqrt{x+11} = \sqrt{8x+9}$

6. $\sqrt{x^2-8} + \sqrt{x^2-14} = 6$

8. $\sqrt{x-2} - \sqrt{x-9} = 1$

10. $\sqrt{\frac{x-1}{3x+2}} + 2\sqrt{\frac{3x+2}{x-1}} = 3$

Indicial Equation

The equation in which the unknown variable exists as an index/ exponent is called an Indicial or Exponential equation. $2^x = 8$, $16^x = 4^{x+2}$, $2^{x+1} - 2^x - 8 = 0$ etc. are indicial equations, where x is an unknown variable. To solve indicial equations, the following property of indices is often used:

If $a > 0$, $a \neq 1$, then $a^x = a^m$ if and only if $x = m$. That is why both sides of an equation are expressed in powers of the same number.

Activity:

1) Express 4096 in powers of $\frac{1}{2}$, 2, 4, 8, 16, $2\sqrt{2}$ and $\sqrt[3]{4}$.

2) Express 729 in powers of 3, 9, 27, 16 and $\sqrt[5]{9}$.

3) Express $\frac{64}{729}$ in powers of $\frac{3}{2}$ and $\sqrt[3]{\frac{3}{2}}$.

Example 11. Solve: $2^{x+7} = 4^{x+2}$

Solution: $2^{x+7} = 4^{x+2}$

or, $2^{x+7} = (2^2)^{x+2}$

or, $2^{x+7} = 2^{2x+4}$

or, $x + 7 = 2x + 4$

or, $x = 3$

\therefore Required solution $x = 3$

Example 12. Solve: $3 \cdot 27^x = 9^{x+4}$

Solution: $3 \cdot 27^x = 9^{x+4}$

$$\text{or, } 3 \cdot (3^3)^x = (3^2)^{x+4}$$

$$\text{or, } 3 \cdot 3^{3x} = 3^{2(x+4)}$$

$$\text{or, } 3^{3x+1} = 3^{2x+8}$$

$$\text{or, } 3x + 1 = 2x + 8$$

$$\text{or, } x = 7$$

\therefore Required solution $x = 7$

Example 13. Solve: $3^{mx-1} = 3a^{mx-2}$ ($a > 0, a \neq 3, m \neq 0$)

Solution: $3^{mx-1} = 3a^{mx-2}$

$$\text{or, } \frac{3^{mx-1}}{3} = a^{mx-2} \text{ [dividing both sides by 3]}$$

$$\text{or, } 3^{mx-2} = a^{mx-2}$$

$$\text{or, } \left(\frac{a}{3}\right)^{mx-2} = 1 = \left(\frac{a}{3}\right)^0$$

$$\text{or, } mx - 2 = 0$$

$$\text{or, } mx = 2$$

$$\text{or, } x = \frac{2}{m}$$

\therefore Required solution $x = \frac{2}{m}$

Example 14. Solve: $2^{3x-5} \cdot a^{x-2} = 2^{x-3} \cdot 2a^{1-x}$ ($a > 0$ and $a \neq \frac{1}{2}$)

Solution: $2^{3x-5} \cdot a^{x-2} = 2^{x-3} \cdot 2a^{1-x}$

$$\text{or, } \frac{a^{x-2}}{a^{1-x}} = \frac{2^{x-3} \cdot 2^1}{2^{3x-5}} \text{ or, } a^{x-2-1+x} = 2^{x-3+1-3x+5}$$

$$\text{or, } a^{2x-3} = 2^{-2x+3} \text{ or, } a^{2x-3} = 2^{-(2x-3)}$$

$$\text{or, } a^{2x-3} = \frac{1}{2^{2x-3}} \text{ or, } a^{2x-3} \cdot 2^{2x-3} = 1$$

$$\text{or, } (2a)^{2x-3} = 1 = (2a)^0$$

$$\text{or, } 2x - 3 = 0 \text{ or, } 2x = 3 \text{ or, } x = \frac{3}{2}$$

\therefore Required solution $x = \frac{3}{2}$

Example 15. Solve: $a^{-x}(a^x + b^{-x}) = \frac{a^2b^2 + 1}{a^2b^2}$ ($a > 0, b > 0, ab \neq 1$)

Solution: $a^{-x}(a^x + b^{-x}) = 1 + \frac{1}{a^2b^2}$

or, $a^{-x} \cdot a^x + a^{-x} \cdot b^{-x} = 1 + \frac{1}{a^2b^2}$

or, $1 + (ab)^{-x} = 1 + (ab)^{-2}$

or, $(ab)^{-x} = (ab)^{-2}$

or, $-x = -2$

or, $x = 2$

\therefore Required solution $x = 2$

Example 16. Solve: $3^{x+5} = 3^{x+3} + \frac{8}{3}$

Solution: $3^{x+5} = 3^{x+3} + \frac{8}{3}$

or, $3^x \cdot 3^5 = 3^x \cdot 3^3 + \frac{8}{3}$

or, $3^x \cdot 3^6 - 3^x \cdot 3^4 = 8$ [multiplying both sides by 3 and then transposing]

or, $3^x \cdot 3^4(3^2 - 1) = 8$

or, $3^{x+4} \cdot 8 = 8$

or, $3^{x+4} = 1 = 3^0$

or, $x + 4 = 0$ or, $x = -4$

\therefore Required solution $x = -4$

Example 17. Solve: $3^{2x-2} - 5 \cdot 3^{x-2} - 66 = 0$

Solution: $3^{2x-2} - 5 \cdot 3^{x-2} - 66 = 0$

or, $\frac{3^{2x}}{9} - \frac{5}{9} \cdot 3^x - 66 = 0$

or, $3^{2x} - 5 \cdot 3^x - 594 = 0$ [multiplying both sides by 9]

or, $a^2 - 5a - 594 = 0$ [taking $3^x = a$]

or, $a^2 - 27a + 22a - 594 = 0$

Forma-15, Higher Mathe Class-9-10

$$\text{or, } (a - 27)(a + 22) = 0$$

Now $a \neq -22$ since $a = 3^x > 0$, $\therefore a + 22 \neq 0$

$$\text{Thus, } a - 27 = 0$$

$$\text{or, } 3^x = 27 = 3^3$$

$$\text{or, } x = 3$$

Required solution: $x = 3$

Example 18. Solve: $a^{2x} - (a^3 + a)a^{x-1} + a^2 = 0$ ($a > 0, a \neq 1$)

$$\text{Solution: } a^{2x} - (a^3 + a)a^{x-1} + a^2 = 0$$

$$\text{or, } a^{2x} - a(a^2 + 1)a^x \cdot a^{-1} + a^2 = 0$$

$$\text{or, } a^{2x} - (a^2 + 1)a^x + a^2 = 0$$

$$\text{or, } p^2 - (a^2 + 1)p + a^2 = 0 \text{ [Taking } a^x = p]$$

$$\text{or, } p^2 - a^2p - p + a^2 = 0$$

$$\text{or, } (p - 1)(p - a^2) = 0$$

$$\text{or, } p = 1 \text{ or } p = a^2$$

$$\text{or, } a^x = 1 = a^0 \text{ or } a^x = a^2$$

$$\text{or, } x = 0 \text{ or } x = 2$$

\therefore Required solution $x = 0, 2$

Exercise 5.3

Solve:

$$1. \quad 3^{x+2} = 81$$

$$2. \quad 5^{3x-7} = 3^{3x-7}$$

$$3. \quad 2^{x-4} = 4a^{x-6} \quad (a > 0, a \neq 2)$$

$$4. \quad (\sqrt{3})^{x+5} = (\sqrt[3]{3})^{2x+5}$$

$$5. \quad (\sqrt[5]{4})^{4x+7} = (\sqrt[11]{64})^{2x+7}$$

$$6. \quad \frac{3^{3x-4} \cdot a^{2x-5}}{3^{x+1}} = a^{2x-5} \quad (a > 0)$$

$$7. \quad \frac{5^{2x} \cdot b^{x-3}}{5^{x+3}} = a^{x-3} \quad (a, b > 0, 5b \neq a)$$

$$8. \quad 4^{x+2} = 2^{2x+1} + 14$$

$$9. \quad 5^x + 5^{2-x} = 26$$

$$10. \quad 3(9^x - 4 \cdot 3^{x-1}) + 1 = 0$$

$$11. \quad 4^{1+x} + 4^{1-x} = 10$$

$$12. \quad 2^{2x} - 3 \cdot 2^{x+2} = -32$$

System of quadratic equations with two variables

The method of solution of the system of two linear equations with two variables or the system of two equations of which one is linear and the other is quadratic with two variables have been discussed in the Secondary Algebra Book. Here we will discuss the solution methodology of some systems involving two such quadratic equations. It may be mentioned that if x and y are two variables of any system, then $(x, y) = (a, b)$ is a solution of this system when both sides of the two equations will be equal if we substitute a for x and b for y .

Example 19. Solve: $x + \frac{1}{y} = \frac{3}{2}$, $y + \frac{1}{x} = 3$

Solution: $x + \frac{1}{y} = \frac{3}{2} \dots (1)$

$$y + \frac{1}{x} = 3 \dots (2)$$

From (1) $xy + 1 = \frac{3}{2}y \dots (3)$

From (2), $xy + 1 = 3x \dots (4)$

From (3) and (4) $\frac{3}{2}y = 3x$ or, $y = 2x \dots (5)$

Putting the value of y from (5) in (4) we get,

$$2x^2 + 1 = 3x \text{ or, } 2x^2 - 3x + 1 = 0$$

$$\text{or, } (x - 1)(2x - 1) = 0 \therefore x = 1 \text{ or } \frac{1}{2}$$

From (5) we get, when $x = 1$, $y = 2$ and when $x = \frac{1}{2}$, $y = 1$

\therefore Required solution $(x, y) = (1, 2), \left(\frac{1}{2}, 1\right)$

Example 20. Solve: $x^2 = 3x + 6y$, $xy = 5x + 4y$

Solution: $x^2 = 3x + 6y \dots (1)$

$$xy = 5x + 4y \dots (2)$$

Subtracting (2) from (1), $x(x - y) = -2(x - y)$

$$\text{or, } x(x - y) + 2(x - y) = 0$$

$$\text{or, } (x - y)(x + 2) = 0$$

$$\therefore x = y \cdots (3)$$

$$\text{or, } x = -2 \cdots (4)$$

From (3) and (1) we get, $y^2 = 9y$ or, $y(y - 9) = 0 \therefore y = 0$ or 9

From (3), when $y = 0$, $x = 0$ and when $y = 9$, $x = 9$

Again from (4) and (1) we get, $x = -2$ and $4 = -6 + 6y$ or, $6y = 10$ or, $y = \frac{5}{3}$

\therefore Required solution $(x, y) = (0, 0), (9, 9), (-2, \frac{5}{3})$

Example 21. Solve: $x^2 + y^2 = 61$, $xy = -30$

Solution: $x^2 + y^2 = 61 \cdots (1)$

$$xy = -30 \cdots (2)$$

Multiplying equation (2) by 2 and subtracting the result from (1) we get, $(x - y)^2 = 121$

$$\text{or, } (x - y) = \pm 11 \cdots (3)$$

Multiplying equation (2) by 2 and adding the result with (1) we get, $(x + y)^2 = 1$

$$\text{or, } x + y = \pm 1 \cdots (4)$$

From (3) and (4) we get,

$$\left. \begin{array}{l} x + y = 1 \\ x - y = 11 \end{array} \right\} \cdots (5)$$

$$\left. \begin{array}{l} x + y = 1 \\ x - y = -11 \end{array} \right\} \cdots (6)$$

$$\left. \begin{array}{l} x + y = -1 \\ x - y = 11 \end{array} \right\} \cdots (7)$$

$$\left. \begin{array}{l} x + y = -1 \\ x - y = -11 \end{array} \right\} \cdots (8)$$

Solving we get,

From (5), $x = 6, y = -5$ From (6), $x = -5, y = 6$

From (7), $x = 5, y = -6$ From (8) $x = -6, y = 5$

\therefore Required solution $(x, y) = (6, -5), (-5, 6), (5, -6), (-6, 5)$

Example 22. Solve: $x^2 - 2xy + 8y^2 = 8$, $3xy - 2y^2 = 4$

Solution: $x^2 - 2xy + 8y^2 = 8 \dots (1)$

$$3xy - 2y^2 = 4 \dots (2)$$

From (1) and (2) we get,

$$\frac{x^2 - 2xy + 8y^2}{3xy - 2y^2} = \frac{2}{1}$$

or, $x^2 - 2xy + 8y^2 = 6xy - 4y^2$

or, $x^2 - 8xy + 12y^2 = 0$

or, $x^2 - 6xy - 2xy + 12y^2 = 0$

or, $(x - 6y)(x - 2y) = 0$

$\therefore x = 6y \dots (3)$ or, $x = 2y \dots (4)$

Putting the value of x in (2) from (3) we get,

$$3 \cdot 6y \cdot y - 2y^2 = 4 \text{ or, } 16y^2 = 4 \text{ or, } y^2 = \frac{1}{4} \text{ or, } y = \pm \frac{1}{2}$$

From (3), $x = 6 \times \left(\pm \frac{1}{2}\right) = \pm 3$

Again putting the value of x from (4) in (2) we get,

$$3 \cdot 2y \cdot y - 2y^2 = 4 \text{ or, } 4y^2 = 4 \text{ or, } y^2 = 1 \text{ or, } y = \pm 1$$

From (4) $x = 2 \times (\pm 1) = \pm 2$

\therefore Required solution $(x, y) = \left(3, \frac{1}{2}\right), \left(-3, -\frac{1}{2}\right), (2, 1), (-2, -1)$

Example 23. Solve: $\frac{x+y}{x-y} + \frac{x-y}{x+y} = \frac{5}{2}, x^2 + y^2 = 90$

Solution: $\frac{x+y}{x-y} + \frac{x-y}{x+y} = \frac{5}{2} \dots (1)$

$$x^2 + y^2 = 90 \dots (2)$$

From (1) we get,

$$\frac{(x+y)^2 + (x-y)^2}{(x+y)(x-y)} = \frac{5}{2}$$

or, $\frac{2(x^2 + y^2)}{x^2 - y^2} = \frac{5}{2}$

or, $\frac{2 \times 90}{x^2 - y^2} = \frac{5}{2}$ [Putting $x^2 + y^2 = 90$ from (2)]

or, $x^2 - y^2 = 72 \dots (3)$

(2) + (3) implies, $2x^2 = 162$ or, $x^2 = 81$ or, $x = \pm 9$

and (2) - (3) implies, $2y^2 = 18$ or, $y^2 = 9$ or, $y = \pm 3$

\therefore Required solution $(x, y) = (9, 3), (9, -3), (-9, 3), (-9, -3)$

Work: Find the solutions of Example 20 and 21 using some alternative way.

Exercises 5.4

Solve :

1. $(2x + 3)(y - 1) = 14, (x - 3)(y - 2) = -1$
2. $(x - 2)(y - 1) = 3, (x + 2)(2y - 5) = 15$
3. $x^2 = 7x + 6y, y^2 = 7y + 6x$
4. $x^2 = 3x + 2y, y^2 = 3y + 2x$
5. $x + \frac{4}{y} = 1, y + \frac{4}{x} = 25$
6. $y + 3 = \frac{4}{x}, x - 4 = \frac{5}{3y}$
7. $xy - x^2 = 1, y^2 - xy = 2$
8. $x^2 - xy = 14, y^2 + xy = 60$
9. $x^2 + y^2 = 25, xy = 12$
10. $\frac{x + y}{x - y} + \frac{x - y}{x + y} = \frac{10}{3}, x^2 - y^2 = 3$
11. $x^2 + xy + y^2 = 3, x^2 - xy + y^2 = 7$
12. $2x^2 + 3xy + y^2 = 20, 5x^2 + 4y^2 = 41$

Applications of simultaneous quadratic equations

Many problems of everyday life can be solved using the knowledge of simultaneous equations. Sometimes, we are to find out the values of two unknown quantities of

the problem. In that case, the two unknown quantities are taken as x and y or any other symbols. Then consistent and independent equations are formed according to the conditions of the problem. The values of the unknown quantities x and y are obtained by solving these equations.

Example 24. The sum of the areas of the two square regions is 650 square metres. If the area of the rectangular region formed by the two sides of the two squares is 323 square metres, what are the lengths of the sides of the two squares?

Solution: Suppose, the length of the side of one square is x metres and that of the other square is y metres.

According to the question, $x^2 + y^2 = 650 \dots (1)$

and, $xy = 323 \dots (2)$

$\therefore (x + y)^2 = x^2 + y^2 + 2xy = 650 + 646 = 1296$

i.e. $(x + y) = \pm\sqrt{1296} = \pm 36$

and, $(x - y)^2 = x^2 + y^2 - 2xy = 650 - 646 = 4$

i.e. $(x - y) = \pm 2$

Since the length is positive, the value of $x + y$ must be positive.

$\therefore (x + y) = 36 \dots (3)$ and $(x - y) = \pm 2 \dots (4)$

Adding, $2x = 36 \pm 2$

$\therefore x = \frac{36 \pm 2}{2} = 18 \pm 1 = 19$ or, 17

From equation (3) we get, $y = 36 - x = 17$ or, 19

\therefore The length of the side of one square is 19 metres and that of the other square is 17 metres.

Example 25. Twice the breadth of a rectangle is 10 metres more than its length. If the area of the region enclosed by the rectangle is 600 square metres, find its length.

Solution: Suppose that the length of the rectangle is x metres and the breadth of the rectangle is y metres.

According to the question, $2y = x + 10 \dots (1)$

$xy = 600 \dots (2)$

From equation (1) we get, $y = \frac{10 + x}{2}$

putting the value of y in equation (2) y we get, $\frac{x(10 + x)}{2} = 600$

$$\text{or, } \frac{10x + x^2}{2} = 600 \text{ or, } x^2 + 10x = 1200$$

$$\text{or, } x^2 + 10x - 1200 = 0 \text{ or, } (x + 40)(x - 30) = 0$$

Therefore, $x + 40 = 0$ or, $x - 30 = 0$

$$\text{i.e. } x = -40 \text{ or, } x = 30$$

But length cannot be negative, $\therefore x = 30$

\therefore Hence, the length of the rectangle = 30 meter.

Example 26. If a number of two digits be divided by the product of its digits, the quotient is 3. When 18 is added to the number, the digits of the number change their places. Find the number.

Solution: Suppose, tens' place digit is x and ones' place digit is y

$$\therefore \text{The number} = 10x + y$$

$$\text{From the 1st condition, } \frac{10x + y}{xy} = 3 \text{ or, } 10x + y = 3xy \cdots (1)$$

$$\text{From the 2nd condition, } 10x + y + 18 = 10y + x \text{ or, } 9x - 9y + 18 = 0$$

$$\text{or, } x - y + 2 = 0 \text{ or, } y = x + 2 \cdots (2)$$

$$\text{Putting } y = x + 2 \text{ in (1) we get, } 10x + x + 2 = 3 \cdot x(x + 2)$$

$$\text{or, } 11x + 2 = 3x^2 + 6x$$

$$\text{or, } 3x^2 - 5x - 2 = 0$$

$$\text{or, } 3x^2 - 6x + x - 2 = 0$$

$$\text{or, } 3x(x - 2) + 1(x - 2) = 0$$

$$\text{or, } (x - 2)(3x + 1) = 0$$

$$\therefore x - 2 = 0 \text{ or } 3x + 1 = 0$$

$$\text{i.e. } x = 2 \text{ or, } x = -\frac{1}{3}$$

But the digit or a number cannot be negative or fraction.

$$\therefore x = 2 \text{ and } y = x + 2 = 2 + 2 = 4$$

\therefore The requires number is 24

Exercise 5.5

1. The sum of the areas of two square regions is 481 square metres; if the area of the rectangle formed by the two sides of the two squares is 240 square metres, what are the lengths of a side of each of the squares?
2. The sum of the squares of two positive numbers is 250; the product of the numbers is 117; find the two numbers.
3. The length of a diagonal of a rectangle is 10 metres. The area of a rectangle whose sides are the sum and difference of the sides of the former one is 28 square metres. Find the length and breadth of the former rectangle.
4. The sum of squares of two numbers is 181 and the product of the numbers is 90. Find the difference of the squares of the two numbers.
5. The area enclosed by a rectangle is 24 square metres. The length and breadth of another rectangle are respectively 4 metres and 1 metre more than the length and breadth of the first rectangle and the area enclosed by the later rectangle is 50 square metres. Find the length and breadth of the first rectangle.
6. Twice the breadth of a rectangle is 23 metres more than its length. If the area enclosed by the rectangle is 600 square metres, find the length and breadth of the rectangle.
7. The perimeter of a rectangle is 8 metres more than the sum of its diagonals. If the area enclosed by the rectangle is 48 square metres; find its length and breadth.
8. If a number of two digits be divided by the product of its digits, the quotient is 2. When 27 is added to the number, the digits in the number change their places. Find the number.
9. The perimeter of a rectangular garden is 56 metres and one diagonal is 20 metres. What is the length of the side of the square which encloses an area equal to the area of that garden?
10. The area of a rectangular field is 300 square metres and its semi-perimeter is 10 metres more than a diagonal. Find the length and breadth of the rectangular field.

System of indicial equations with two variables

The method of solution of identical equations with one variable has been discussed in the previous chapter. Here we will discuss the solution methodology of the system of indicial equations with two variables.

Example 27. Solve: $a^{x+2} \cdot a^{2y+1} = a^{10}$, $a^{2x} \cdot a^{y+1} = a^9$ ($a \neq 1$)

Solution: $a^{x+2} \cdot a^{2y+1} = a^{10} \dots (1)$ $a^{2x} \cdot a^{y+1} = a^9 \dots (2)$

From (1), $a^{x+2y+3} = a^{10}$ or, $x + 2y + 3 = 10$ or, $x + 2y - 7 = 0 \dots (3)$

From (2), $a^{2x+y+1} = a^9$ or, $2x + y + 1 = 9$ or, $2x + y - 8 = 0 \dots (4)$

From (3) and (4) by the method of cross-multiplication,

$$\frac{x}{-16 + 7} = \frac{y}{-14 + 8} = \frac{1}{1 - 4}$$

$$\text{or, } \frac{x}{-9} = \frac{y}{-6} = \frac{1}{-3}$$

$$\text{or, } \frac{x}{3} = \frac{y}{2} = 1$$

$$\text{or, } x = 3, y = 2$$

\therefore Required solution $(x, y) = (3, 2)$

Example 28. Solve: $3^{3y-1} = 9^{x+y}$, $4^{x+3y} = 16^{2x+3}$

Solution: $3^{3y-1} = 9^{x+y} \dots (1)$

or, $3^{3y-1} = (3^2)^{x+y}$ or, $3^{3y-1} = 3^{2x+2y}$

or, $3y - 1 = 2x + 2y$

or, $2x - y + 1 = 0 \dots (2)$

and $4^{x+3y} = 16^{2x+3} \dots (3)$

$$\text{or, } 4^{x+3y} = (4^2)^{2x+3} \text{ or, } 4^{x+3y} = 4^{4x+6}$$

$$\text{or, } x + 3y = 4x + 6 \text{ or, } 3x - 3y + 6 = 0$$

$$\text{or, } x - y + 2 = 0 \dots (4)$$

From (2) and (4) by the method of cross-multiplication,

$$\frac{x}{-2+1} = \frac{y}{1-4} = \frac{1}{-2+1}$$

$$\text{or, } \frac{x}{-1} = \frac{y}{-3} = -1$$

$$\text{or, } x = 1, y = 3$$

\therefore Required solution $(x, y) = (1, 3)$

Example 29. Solve: $x^y = y^x, x = 2y$

Solution: $x^y = y^x \dots (1)$ $x = 2y \dots (2)$ here, $x \neq 0, y \neq 0$

Putting the value of x in (1) from (2) we get, $(2y)^y = y^{2y}$ or, $2^y \cdot y^y = y^{2y}$

$$\text{or, } \frac{y^{2y}}{y^y} = 2^y \text{ or, } y^y = 2^y \therefore y = 2$$

From (2), $x = 4$

\therefore Required solution $(x, y) = (4, 2)$

Example 30. Solve: $x^y = y^2, y^{2y} = x^4$, where $x \neq 1$

Solution: $x^y = y^2 \dots (1)$ $y^{2y} = x^4 \dots (2)$

From (1) we get, $(x^y)^y = (y^2)^y$ or, $x^{y^2} = y^{2y} \dots (3)$

From (3) and (2) we get, $x^{y^2} = x^4$

$$\therefore y^2 = 4 \text{ or, } y = \pm 2$$

Now, if $y = 2$, from (1) we get, $x^2 = 2^2 = 4$ or, $x = \pm 2$

Again, if $y = -2$, from (1) we get, $x^{-2} = (-2)^2 = 4$ or, $x^2 = \frac{1}{4}$ or, $x = \pm \frac{1}{2}$

\therefore Required solution $(x, y) = (2, 2), (-2, 2), \left(\frac{1}{2}, -2\right), \left(-\frac{1}{2}, -2\right)$

Example 31. Solve: $8 \cdot 2^{xy} = 4^y, 9^x \cdot 3^{xy} = \frac{1}{27}$

Solution: $8 \cdot 2^{xy} = 4^y \dots (1)$ $9^x \cdot 3^{xy} = \frac{1}{27} \dots (2)$

From (1) we get, $2^3 \cdot 2^{xy} = (2^2)^y$ or, $2^{3+xy} = 2^{2y}$ or, $3 + xy = 2y \dots (3)$

From (2) we get, $(3^2)^x \cdot 3^{xy} = \frac{1}{3^3}$ or, $3^{2x+xy} = 3^{-3}$ or, $2x + xy = -3 \dots (4)$

Subtracting (4) from (3) we get, $3 - 2x = 2y + 3$ or, $-x = y \dots (5)$

Putting the value of y in (3) from (5) we get, $3 - x^2 = -2x$

or, $x^2 - 2x - 3 = 0$ or, $(x + 1)(x - 3) = 0$

$\therefore x = -1$ or $x = 3$

If $x = -1$, from (5) we get, $y = 1$

If $x = 3$, from (5) we get, $y = -3$

\therefore Required solution $(x, y) = (-1, 1), (3, -3)$

Example 32. Solve: $18y^x - y^{2x} = 81, 3^x = y^2$

Solution: $18y^x - y^{2x} = 81 \dots (1)$ $3^x = y^2 \dots (2)$

(1) we get, $y^{2x} - 18y^x + 81 = 0$ or, $(y^x - 9)^2 = 0$

or, $y^x - 9 = 0$ or, $y^x = 3^2 \dots (3)$

From (2) we get, $(3^x)^x = (y^2)^x$ or, $3^{x^2} = y^{2x} \dots (4)$

From (3) we get, $(y^x)^2 = (3^2)^2$ or, $y^{2x} = 3^4 \dots (5)$

From (4) and (5) we get, $3^{x^2} = 3^4$

$\therefore x^2 = 4$ or, $x = \pm 2$

If $x = 2$ from (2) we get, $y^2 = 9$ or, $y = \pm 3$

If $x = -2$ from (3) we get, $y^{-2} = 9$ or, $y^2 = \frac{1}{9}$ or, $y = \pm \frac{1}{3}$

\therefore Required solution $(x, y) = (2, 3), (2, -3), \left(-2, \frac{1}{3}\right), \left(-2, -\frac{1}{3}\right)$

Exercise 5.6

Solve:

1. $2^x + 3^y = 31$

$2^x - 3^y = -23$

2. $3^x = 9^y$

$5^{x+y+1} = 25^{xy}$

$$3. \quad \begin{aligned} 3^x \cdot 9^y &= 81 \\ 2x - y &= 8 \end{aligned}$$

$$4. \quad \begin{aligned} 2^x \cdot 3^y &= 18 \\ 2^{2x} \cdot 3^y &= 36 \end{aligned}$$

$$5. \quad \begin{aligned} a^x \cdot a^{y+1} &= a^7 \\ a^{2y} \cdot a^{3x+5} &= a^{20} \end{aligned}$$

$$6. \quad \begin{aligned} y^x &= x^2 \\ x^{2x} &= y^4 \quad (y \neq 1) \end{aligned}$$

$$7. \quad \begin{aligned} y^x &= 4 \\ y^2 &= 2^x \end{aligned}$$

$$8. \quad \begin{aligned} 4^x &= 2^y \\ (27)^{xy} &= 9^{y+1} \end{aligned}$$

$$9. \quad \begin{aligned} 8y^x - y^{2x} &= 16 \\ 2^x &= y^2 \end{aligned}$$

Solving quadratic equation using graph

We have already solved the quadratic equation $ax^2 + bx + c = 0$ algebraically. Method of solving it using graphs will be discussed now.

Suppose $y = ax^2 + bx + c$. Then the values of x for which $y = 0$ (i.e. the graph of y intersects the X -axis) are the solutions of $ax^2 + bx + c = 0$.

Example 33. Use graph to solve $x^2 - 5x + 4 = 0$.

Solution: Given equation $x^2 - 5x + 4 = 0 \dots (1)$ Suppose, $y = x^2 - 5x + 4 \dots (2)$

For some values of x , we find the corresponding values of y to get the associated points on the graph and put these in the table below.

x	0	1	2	2.5	3	4	5
y	4	0	-2	-2.25	-2	0	4

We draw the graph of equation (2) plotting the points given in the above table.

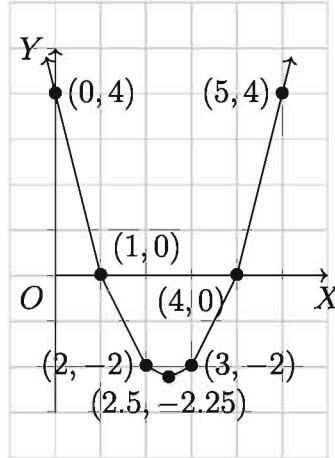

It is seen that the graph intersects the X -axis at $(1, 0)$ and $(4, 0)$.

\therefore the solution of equation (1) is $x = 1, x = 4$.

Example 34. Solve $x^2 - 4x + 4 = 0$ graphically.

Solution: Given equation $x^2 - 4x + 4 = 0 \dots (1)$ Suppose, $y = x^2 - 4x + 4 \dots (2)$

We find the values of y corresponding to some values of x which give the associated points for the graph:

x	0	1	1.5	2	2.5	3	4
y	4	1	0.25	0	0.25	1	4

Now we draw the graph of equation (2) plotting the points given in the above table.

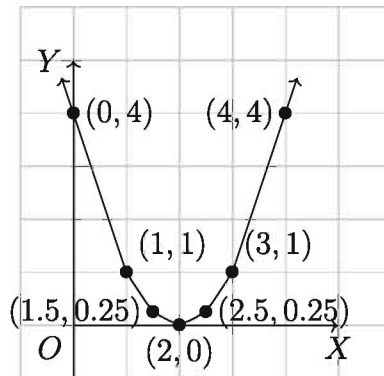

It is seen that the graph intersects the X -axis at $(2, 0)$.

Since a quadratic equation has two roots, the solutions of the equation are $x =$

2, $x = 2$.

Example 35. Solve $x^2 - 2x - 1 = 0$ graphically.

Solution: Given equation $x^2 - 2x - 1 = 0 \dots (1)$ Suppose, $y = x^2 - 2x - 1 \dots (2)$

For some values of x , we find the corresponding values of y that give the associated points on the graph:

x	-1	-0.5	0	0.5	1	1.5	2	2.5	3
y	2	0.25	-1	-1.75	-2	-1.75	-1	0.25	2

We sketch the graph of equation (2) plotting the tabulated points in the graph paper.

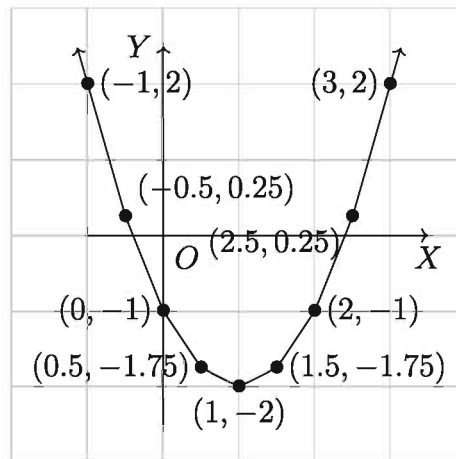

It is observed that the graph intersects the X -axis approximately at $(-0.4, 0)$ and $(2.4, 0)$. Therefore, the solution of equation (1) is $x = -0.4$ (approx.) or $x = 2.4$ (approx.)

Example 36. Find both the roots of $-x^2 + 3x - 2 = 0$ graphically.

Solution: Given equation $-x^2 + 3x - 2 = 0 \dots (1)$ Suppose, $y = -x^2 + 3x - 2 \dots (2)$

For some values of x , we find the associated values of y to get the related points of the graph of the equation and put these in the table given below.

x	0	0.5	1	1.5	2	2.5	3
y	-2	-0.75	0	0.25	0	-0.75	-2

Plotting the points obtained in the graph paper, we get the graph of the equation.

We see that the graph passes through the points $(1, 0)$ and $(2, 0)$ on the X -axis. Therefore, the solution of the equation is $x = 1$ or $x = 2$.

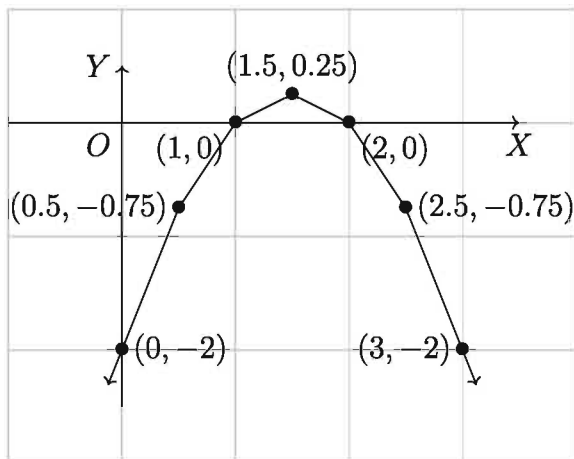

Example 37. $x^2 + 4x = m$

- 1) If $m = -4$, find the value of x .
- 2) If $m = 5$, find the discriminant of the equation and the nature of roots.
- 3) If $\sqrt{m-4} + \sqrt{m-10} = 6$, find the value of x .

Solution:

- 1) Given that, $x^2 + 4x = m$

Now, if $m = -4$ then $x^2 + 4x = -4$

or, $x^2 + 4x + 4 = 0$

or, $(x + 2)^2 = 0$

or, $x + 2 = 0, x + 2 = 0$

$\therefore x = -2, -2$

- 2) Given that, $x^2 + 4x = m$

Now, if $m = 5$, $x^2 + 4x = 5$

or, $x^2 + 4x - 5 = 0$

Discriminant of the equation $= 4^2 - 4 \cdot 1 \cdot (-5) = 16 + 20 = 36$, which is a perfect square.

Since the discriminant is positive, perfect square number, the roots of the equation are real, unequal and rational.

$$\begin{aligned}
3) \quad & \text{Given that, } \sqrt{m-4} + \sqrt{m-10} = 6 \\
& \text{or, } \sqrt{m-4} = 6 - \sqrt{m-10} \\
& \text{or, } (\sqrt{m-4})^2 = (6 - \sqrt{m-10})^2 \\
& \text{or, } m-4 = 6^2 - 2 \cdot 6 \cdot \sqrt{m-10} + m-10 \\
& \text{or, } 12\sqrt{m-10} = 26 + 4 \\
& \text{or, } 12\sqrt{m-10} = 30 \\
& \text{or, } 2\sqrt{m-10} = 5 \\
& \text{or, } (2\sqrt{m-10})^2 = 25 \\
& \text{or, } 4(m-10) = 25 \\
& \text{or, } 4m - 40 - 25 = 0 \\
& \text{or, } 4(x^2 + 4x) - 65 = 0 \\
& \text{or, } 4x^2 + 16x - 65 = 0 \\
& \text{or, } 4x^2 + 26x - 10x - 65 = 0 \\
& \text{or, } 2x(2x + 13) - 5(2x + 13) = 0 \\
& \text{or, } (2x + 13)(2x - 5) = 0 \\
& \therefore 2x + 13 = 0 \text{ or, } 2x - 5 = 0 \\
& \text{or, } 2x = -13 \text{ or, } 2x = 5 \\
& \text{or, } x = -\frac{13}{2} \text{ or, } x = \frac{5}{2} \\
& x = -\frac{13}{2} \text{ or } x = \frac{5}{2} \text{ both values of } x \text{ satisfy the equation.} \\
& \therefore x = -\frac{13}{2}, \frac{5}{2}
\end{aligned}$$

Exercises 5.7

- What is the value of b in equation $ax^2 + bx + c = 0$ while comparing with the equation $x^2 - x - 12 = 0$?
 1) 0 2) 1 3) -1 4) 3
- Which one is the solution of the equation $16^x = 4^{x+1}$?

- 1) 2 2) 1 3) 4 4) 3
3. A root of the equation $x^2 - x - 13 = 0$ is:
- 1) $-\frac{-1 + \sqrt{51}}{2}$ 2) $-\frac{-1 - \sqrt{51}}{2}$
 3) $-\frac{1 + \sqrt{-51}}{2}$ 4) $\frac{1 + \sqrt{53}}{2}$
4. A root of the system of equations $y^x = 9, y^2 = 3^x$ is:
- 1) $(-3, -3)$ 2) $\left(2, \frac{1}{3}\right)$
 3) $\left(-2, \frac{1}{3}\right)$ 4) $(-2, 3)$

According to the information given below answer questions 5 and 6.

The difference of the squares of two positive whole numbers is 11 and the product of the numbers is 30.

5. What are the numbers?
- 1) 1 and 30 2) 2 and 15 3) 5 and 6 4) 5 and -6
6. What is the sum of the squares of the numbers?
- 1) 1 2) 5 3) 61 4) $\sqrt{41}$
7. The sum of a number and its multiplicative inverse is 6. The formation of equation is
- (i) $x + \frac{1}{x} = 6$
 (ii) $x^2 + 1 = 6x$
 (iii) $x^2 - 6x - 1 = 0$
- Which one is true?
- 1) *i* and *ii* 2) *i* and *iii* 3) *ii* and *iii* 4) *i, ii* and *iii*
8. Which one is the solution of $2^{px-1} = 2^{2px-2}$?
- 1) $\frac{p}{2}$ 2) p 3) $-\frac{p}{2}$ 4) $\frac{1}{p}$
9. Solve the following equations graphically:
- 1) $x^2 - 4x + 3 = 0$ 2) $x^2 + 2x - 3 = 0$ 3) $x^2 + 7x = 0$
 4) $2x^2 - 7x + 3 = 0$ 5) $2x^2 - 5x + 2 = 0$ 6) $x^2 + 8x + 16 = 0$
 7) $x^2 + x - 3 = 0$ 8) $x^2 = 8$

10. Twice the square of a number is less by 3 than 5 times of the number. But 5 times of the square of that number is greater by 3 than 2 times of the number.
- 1) Form the equation using the information given by the above stimulus.
 - 2) Solve the first equation using formula.
 - 3) Solve the second equation using graph.
11. The area of a land of Mr. Ashfaque Ali is 0.12 hector. One-half of its perimeter is greater by 20 metres than one of its diagonal. He sells one-third of his land to Mr. Shyam. The length of Shyam's land is greater by 5 metres than its breadth.[1 hector = 10,000 square meter]
- 1) Form two equations in the light of stimulus.
 - 2) Find the length and breadth of the land of Mr. Ashfaque Ali.
 - 3) Find the length of a diagonal and the perimeter of the land of Mr. Shyam.
12. $f(x) = x^2 - 6x + 15$ and $g(x) = x^2 - 6x + 13$
- 1) If $f(x) = 7$, find the value of x .
 - 2) If $\sqrt{f(x)} - \sqrt{g(x)} = \sqrt{10} - \sqrt{8}$, solve the equation.
 - 3) Draw the graph of $g(x)$.
13. If the summation of the digits of five consecutive integers is multiplied by the next five consecutive integers' digits' summation, is it possible that the product might be 120635?
14. The difference between length and breadth of a rectangular region is 1 c.m. If the last digit of its area is 6, then can the length of any of its side be a perfect square?
15. How many times in a day are the hands of a clock in a straight line but in the opposite direction? Find the times.
16. How many times in a day are the hands of a clock perpendicular to each other? Find the times.

17. Interchanging the positions of hour hand and minute hand of a clock may not give a proper time. For example, interchanging their positions at 6 : 00 clock sets the hour hand at exactly 12 and the minute hand at exactly 6—neither 11 : 30 nor 12 : 30. Find such times between 12 : 00 and 1 : 00, which gives mathematically correct times after interchanging the positions of the hands. How many total times are there which gives proper times after interchanging the hand positions?

Chapter 6

Inequality

We have acquired knowledge about equation and equality. But inequality also has an important and significant role in our practical life.

At the end of this chapter, students will be able to-

- ▶ explain the inequality of one and two variables;
- ▶ form and solve simple inequalities of two variables;
- ▶ use inequalities to solve practical mathematical problems;
- ▶ solve inequalities of one and two variables graphically.

Concept of Inequality

Suppose, there are 200 students in a class. Obviously it will be seen that, neither all the students are present in the class, nor all of them are absent always. If the number of present student is x in a particular day we can write $0 < x < 200$. In a similar situation, we see that not all the invited persons are present in a ceremony. Clear conception of inequalities is needed in making dresses and other consumer goods. Essential materials for constructing buildings, printing books and for many other similar works cannot be estimated exactly. So, initially we have to buy or collect those essential materials on the basis of idea. Therefore, it is understood that the knowledge of inequalities is very essential in our everyday life.

In case of real numbers,

$a > b$ if and only if $(a - b)$ is positive therefore $(a - b) > 0$

$a < b$ if and only if $(a - b)$ negative therefore $(a - b) < 0$

Some Laws Regarding Inequality:

1) $a < b \Leftrightarrow b > a$

2) If $a > b$, for any c

$$a + c > b + c \text{ and } a - c > b - c$$

3) If $a > b$, for any c

$$ac > bc \text{ and } \frac{a}{c} > \frac{b}{c} \text{ when } c > 0$$

$$ac < bc \text{ and } \frac{a}{c} < \frac{b}{c} \text{ when } c < 0$$

Example 1. If $x < 2$,

1) $x + 2 < 4$ [Adding 2 in both sides]

2) $x - 2 < 0$ [Subtracting 2 in both sides]

3) $2x < 4$ [Multiplying both sides by 2]

4) $-3x > -6$ [Multiplying both sides by -3]

Here it should be noted that,

$$a \geq b \text{ means } a > b \text{ or } a = b$$

$$a \leq b \text{ means } a < b \text{ or } a = b$$

$$a < b < c \text{ means } a < b \text{ and } b < c \text{ therefore } a < c$$

Example 2. As $3 \geq 1$ is true, $3 > 1$

$$2 \leq 4 \text{ is true since } 2 < 4$$

$$2 < 3 < 4 \text{ is true since } 2 < 3 \text{ and } 3 < 4$$

Activity:

- 1) Express the students in your class whose height is more than 5 feet and lower than 5 feet using inequality.
- 2) If the total number of any examination is 1000, express the marks of an examinee using inequality.

Example 3. Solve and show the solution set on a number line: $4x + 4 > 16$

Solution: Given that, $4x + 4 > 16$

$$\text{or, } 4x + 4 - 4 > 16 - 4 \text{ [Subtracting 4 from both sides]}$$

$$\text{or, } 4x > 12$$

$$\text{or, } \frac{4x}{4} > \frac{12}{4} \text{ [Dividing both sides by 4]}$$

$$\text{or, } x > 3$$

\therefore The required solution $x > 3$

Here the solution set, $S = \{x \in R : x > 3\}$

The solution set is shown on the number line below.

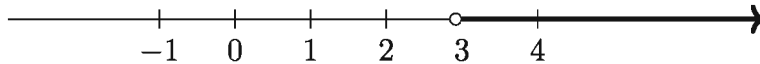

Example 4. Solve and show the solution set on a number line: $x - 9 > 3x + 1$

Solution: Given that, $x - 9 > 3x + 1$

$$\text{or, } x - 9 + 9 > 3x + 1 + 9$$

$$\text{or, } x > 3x + 10$$

$$\text{or, } x - 3x > 3x + 10 - 3x$$

$$\text{or, } -2x > 10$$

$$\text{or, } \frac{-2x}{-2} < \frac{10}{-2} \text{ [the direction of inequality is reversed due to dividing both sides by negative integer } -2\text{]}$$

$$\text{or, } x < -5$$

\therefore The required solution $x < -5$

The solution set is shown on the number line below.

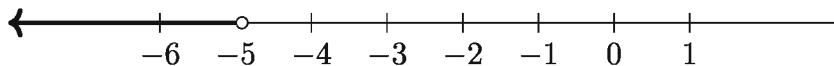

Nota Bene: Just like how the solution of an equation is expressed by an equation (equality), the solution of an inequality are usually expressed by an inequality. The solution set of an inequality is usually an infinite subset of the set of real numbers.

Example 5. Solve: $a(x + b) < c$, $[a \neq 0]$

Solution: If a is positive, $\frac{a(x + b)}{a} < \frac{c}{a}$ [Dividing both sides by a]

$$\text{or, } x + b < \frac{c}{a} \text{ or, } x < \frac{c}{a} - b$$

If a is negative then by the same process we get, $\frac{a(x+b)}{a} > \frac{c}{a}$

or, $x+b > \frac{c}{a}$ or, $x > \frac{c}{a} - b$

\therefore The required solution: (i) $x < \frac{c}{a} - b$ if $a > 0$, (ii) $x > \frac{c}{a} - b$ if $a < 0$.

Nota Bene: If a is zero and c is positive, then the inequality holds for any value of x . But if a is zero and c is negative, then the inequality has no solution.

Exercises 6.1

Solve the inequalities and show the solution set on a number line:

1. $y - 3 < 5$
2. $3(x - 2) < 6$
3. $3x - 2 > 2x - 1$
4. $z \leq \frac{1}{2}z + 3$
5. $8 \geq 2 - 2x$
6. $x \leq \frac{x}{3} + 4$
7. $5(3 - 2t) \leq 3(4 - 3t)$
8. $\frac{x}{3} + \frac{x}{4} + \frac{x}{5} > \frac{47}{60}$

Application of Inequalities

You have learnt to solve problems using equations. Following the same procedure, you will be able to solve problems regarding inequality.

Example 6. In an examination, Roma obtained $5x$ and $6x$ marks and Kumkum obtained $4x$ and 84 marks in Bangla 1st and 2nd paper respectively. None of them secured less than 40 marks in any paper. Kumkum secured the first position and Roma secured the second position in Bangla. Express the possible values of x using inequality.

Solution: The total marks obtained by Roma and Kumkum in Bangla are $5x + 6x$ and $4x + 84$ respectively.

According to the question, $5x + 6x < 4x + 84$

or, $5x + 6x - 4x < 84$ or, $7x < 84$

or, $x < \frac{84}{7}$ or, $x < 12$

But, $4x \geq 40$ [obtained minimum mark is 40] or, $x \geq 10$ or, $10 \leq x$

$\therefore 10 \leq x < 12$

Example 7. A student has bought x pencils at Tk. 5 each and $(x+4)$ notebooks at Tk. 8 each. If the total cost does not exceed Tk. 97, what is the maximum number of pencils he has bought?

Solution: The price of x pencils is Tk. $5x$ and that of $(x + 4)$ notebooks is Tk. $8(x + 4)$.

According to the question, $5x + 8(x + 4) \leq 97$

or, $5x + 8x + 32 \leq 97$

or, $13x \leq 65$

or, $x \leq \frac{65}{13}$

or, $x \leq 5$

\therefore The maximum number of pencils the student has bought is 5.

Activity: Mr. David purchases x kg apples by the rate of Tk 140. He gives the seller a note of 1000 Tk. The seller returns him x number of notes of Tk50. Express the problem in inequalities and find the probable value of x .

Exercises 6.2

Express the problems 1-5 in terms of inequalities and find the possible values of x .

1. A boy walked 3 hours at the rate of x km/hour and ran $\frac{1}{2}$ hour at the rate of $(x + 2)$ km/hour, and the distance covered by him was less than 29 km.
2. A boarding house requires $4x$ kg of rice and $(x-3)$ kg of pulses every day and it does not require more than 40 kg of rice and pulses in total.
3. Mr. Sohrab bought x kg mango at the rate of Tk. 70 per kg. He gave a note of Tk. 500 to the seller. The seller returned him rest of the money with x notes of Tk. 20.
4. A car runs x km. in 4 hours and $(x + 120)$ km in 5 hours. The average speed of the car does not exceed 100 km/hour.
5. The area of a piece of paper is 40 sq cm. A rectangular piece which has a length of x cm. and width of 5 cm is cut off from it.

6. The age of the son is one-third of that of the mother. The father is 6 years older than the mother. The sum of the ages of these three persons is not more than 90 years. Express the age of the father in terms of an inequality.
7. Jeny appeared at the junior scholarship examination at the age of 14 years. She will appear at the S.S.C. examination at the age of 17 years. Express her present age in terms of inequality.
8. The maximum speed of a jet-plane is 300 meters/sec. Express the time required by the plane to cover 15 km in the form of inequality.
9. The air distance of Singapore from Dhaka is 2900 km. The maximum speed of a jet plane is 900 km/hour. But on way from Dhaka to Singapore, it faces air flowing at 100 km/hour from the opposite direction. Express the time required for the nonstop flight from Dhaka to Singapore in terms of an inequality.
10. On the basis of the question above, express the time required for the non-stop flight from Singapore to Dhaka in the form of an inequality.
11. 5 times a positive integer is less than the sum of twice the number and 15. Express the possible value of the number in the form of inequality.

Linear Inequality with Two Variables

We have learned to draw the graph of the linear equations with two variables of the form $y = mx + c$ (whose general form is $ax + by + c = 0$) (in class 8 and class 9-10). We have seen that the graph of each equation of this type is a straight line. In XY plane, co-ordinates of any point on the graph of equation $ax + by + c = 0$ satisfies the equation. That means the left hand side of the equation will be zero if we replace the x and y with the abscissa and ordinate respectively of that point. On the other hand, the co-ordinates of any point outside the graph does not satisfy the equation, in other words for abscissa and ordinate of that point the value of $ax + by + c$ is greater or less than zero. When x and y of the expression $ax + by + c$ are replaced respectively by the abscissa and ordinate of any point P on the plane, the value of the expression is called the value of expression at the point P and that value is generally denoted by $f(P)$. If P is on the graph, $f(P) = 0$, if the point lies outside the graph then $f(P) > 0$ or $f(P) < 0$.

As a matter of fact, in reality all points outside the graph is divided into two half-planes by the graph. For each point P of one half plane, $f(P) > 0$; for each point P of other half plane, $f(P) < 0$. In fact, for each point P on the graph, $f(P) = 0$.

Example 8. Considering the equation $x + y - 3 = 0$.

From the equation we get: $y = 3 - x$

x	0	3	1
y	3	0	2

On the (x, y) plane, taking the length of the side of a small square of the graph paper as unit, the graph of the above equation is shown below:

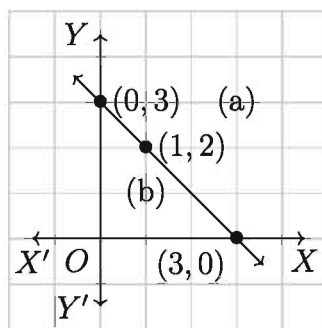

This graph-line divides the plane into three parts. These are:

1. Points on the side marked (a) of the line
2. Points on the side marked (b) of the line and
3. Points which lie on the line

Here the side marked (a) may be called the upper part of the graph-line and the side marked (b) may be called the lower part of the graph-line.

1. Three points $(3, 3)$, $(4, 1)$, $(6, -1)$ are taken on the side marked [(a)]. The values of $x + y - 3$ in these points are 3, 2, 2 respectively, which are all positive.
2. Three points $(0, 0)$, $(1, 1)$, $(-1, -1)$ are taken on the side marked [(b)]. The values of $x + y - 3$ in these points are -3 , -1 , -5 respectively, which are all negative.

Nota Bene: We can determine which side is positive and which side is negative of $ax + by + c = 0$, by taking a point on the one side of the graph of the line and then determining the value of $ax + by + c$ at that point.

Graph of Inequalities with Two Variables

Example 9. Draw the graph of the inequality $x + y - 3 > 0$ or $x + y - 3 < 0$.

Solution: To draw the graph of the above inequalities, we first draw the graph of the equation $x + y - 3 = 0$.

From the equation $x + y - 3 = 0$ we get,

x	0	3	1
y	3	0	2

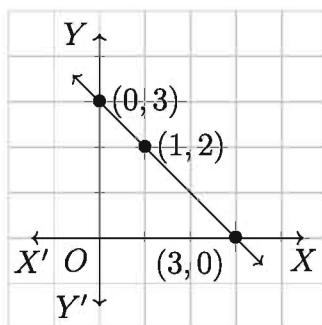

To draw the graph of the inequality $x + y - 3 > 0$, if we put the origin $(0, 0)$ in that equality, we get $-3 > 0$ which is not true. So the graph of the inequality will be on the side of the equation $x + y - 3 = 0$ which is opposite to the side where the origin lies.

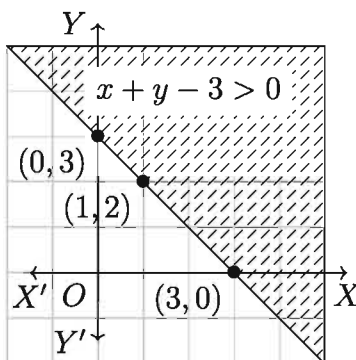

To draw the graph of the inequality $x + y - 3 < 0$, if we put the value of origin $(0, 0)$ in that inequality, we get $-3 < 0$ which satisfies the inequality or true. So the graph of the inequality will be on the same side of the equation $x + y - 3 = 0$ where the origin lies.

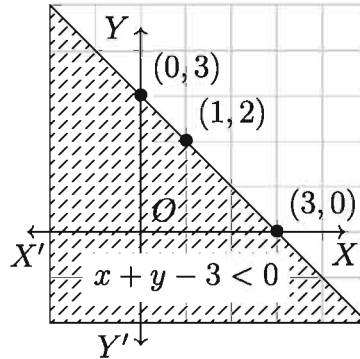

Example 10. Describe the solution set and draw the graph of the inequality $2x - 3y + 6 \geq 0$.

Solution: First we draw the graph of the equation $2x - 3y + 6 = 0$.

From the above equation we have:

$$2x - 3y + 6 = 0 \text{ or, } y = \frac{2x}{3} + 2$$

Co-ordinates of some points on this graph-line are:

x	0	-3	3
y	2	0	4

Now on the squared paper we take length of the side of a small square as unit and then plot the points $(0, 2)$, $(-3, 0)$, $(3, 4)$. Next we draw the graph of the equation by joining these points.

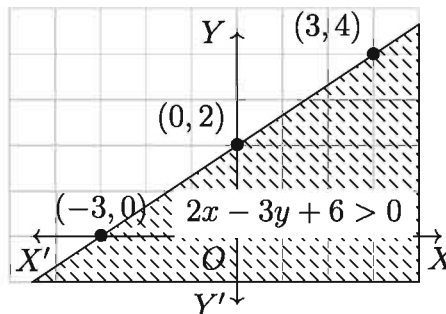

Now at the origin $(0, 0)$, the value of the expression $2x - 3y + 6$ is 6, which is positive. Thus we have $2x - 3y + 6 > 0$ for all points on the origin side of the graph-line.

So, the solution set of the inequality $2x - 3y + 6 \geq 0$ consists of the co-ordinates of all points on the graph line of the equation $2x - 3y + 6 = 0$ and the co-ordinates

of all points on the origin side of the graph line.

The graph of this solution set is the shaded area in the above figure in which the graph-line is also included.

Example 11. In the plane XY , draw the graph of the inequality $-2x < 5$.

Solution: The inequality $-2x < 5$ can be written as.

$$2x + 5 > 0 \text{ or, } 2x > -5 \text{ or, } x > -\frac{5}{2}$$

Now in XY plane we draw the graph of the equation $x = -\frac{5}{2}$. In squared paper, taking the length of two smallest squares as unit we draw the graphline passing through the point $\left(-\frac{5}{2}, 0\right)$ and parallel to the Y axis.

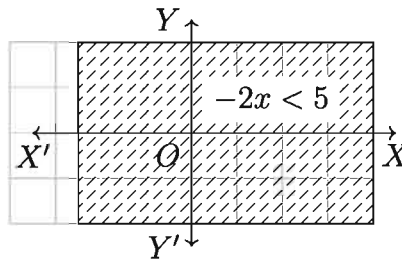

The origin lies at the right side of the graph-line and at origin $x = 0$ which is $> -\frac{5}{2}$.

Therefore, the co-ordinates of all points on the right side of the graph-line are the solutions of the given inequality (points on the graph-line is not considered). The graph of the inequality is the shaded area in the above figure (this does not consist of the graph-line).

Example 12. Draw the graph of the inequality $y \leq 2x$.

Solution: We can write the inequality $y \leq 2x$ in the form of $y - 2x \leq 0$.

Now we draw the graph of the equation $y - 2x = 0$ or $y = 2x$. From the equation we get,

x	0	2	-2
y	0	4	-4

In the graph paper, taking the length of the side of a small square as unit, we plot the points $(0, 0)$, $(2, 4)$, $(-2, -4)$ and by joining them we draw the line.

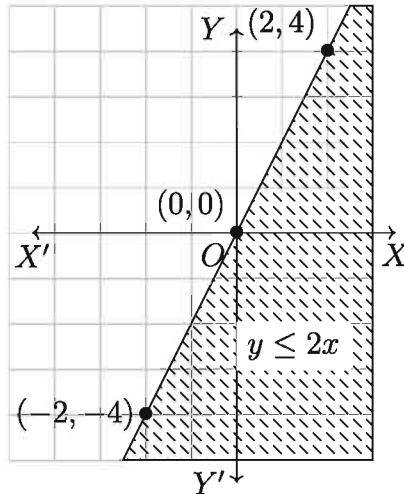

Here, the point $(1, 0)$ lies on the right side of the graph-line. In this point, $y - 2x = 0 - 2 \times 1 = -2 < 0$

Thus the graph of the given inequality consists of the part of the plane which is formed by the graph-line and the part which lies in the right side of it (that is, the part where the point $(1, 0)$ lies).

Exercises 6.3

- Which one is the solution set of the inequality $5x + 5 > 25$?
 - $S = \{x \in R : x > 4\}$
 - $S = \{x \in R : x < 4\}$
 - $S = \{x \in R : x \leq 4\}$
 - $S = \{x \in R : x \geq 4\}$
- For which value of x , it will be $y = 0$ for the equation $x + y = -2$?
 - 2
 - 0
 - 4
 - 2
- Which are the correct co-ordinates of the equation $2xy + y = 3$?
 - $(1, -1), (2, -1)$
 - $(1, 1), (-1, -3)$
 - $(1, 1), (-2, 1)$
 - $(-1, 1), (2, -1)$

Answer the question 4 and 5 from the inequality given below:

$$x \leq \frac{x}{4} + 3$$

- Which one is the solution set of the inequality?
 - $S = \{x \in R : x > 4\}$
 - $S = \{x \in R : x < 4\}$
 - $S = \{x \in R : x \leq 4\}$
 - $S = \{x \in R : x \geq 4\}$

5. Which one is the number line of the solution set of the above inequality?

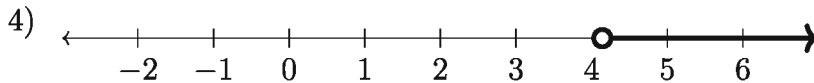
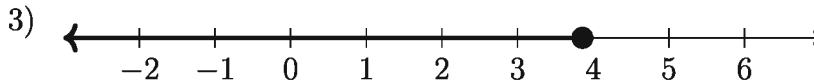
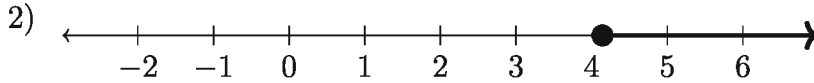
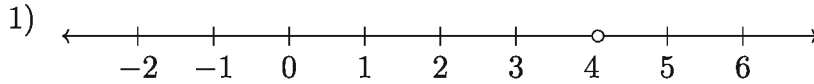

6. For the inequality $3x + 6 > 9$

(i) Dividing both sides by 3, we get $x + 2 > 3$

(ii) Solution set = $\{x \in R : x > 1\}$

(iii) Solution set in the number line:

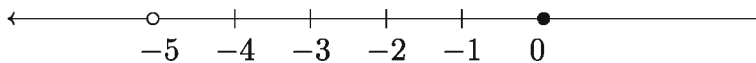

Which of the followings is correct?

1) *i* and *ii* 2) *i* and *iii* 3) *ii* and *iii* 4) *i*, *ii* and *iii*

7. The ages of Rita, Mita and Bithi are x , $2x$ and $3x$ years respectively. If the sum of their age is not more than 60 years

(i) the mathematical expression of the problem is $x + 2x + 3x \leq 60$

(ii) age of Rita is ≤ 10 years

(iii) age of Mita is > 20 years

Which of the followings is correct?

1) *i*, *ii* 2) *i*, *iii* 3) *ii*, *iii* 4) *i*, *ii* and *iii*

8. a , b and c are three real numbers. If $a > b$ and $c \neq 0$

(i) $ac > bc$ when $c > 0$

(ii) $ac < bc$ when $c < 0$

(iii) $\frac{a}{c} > \frac{b}{c}$ when $c > 0$

Which of the following is correct?

- 1) i, ii 2) i, iii 3) ii, iii 4) i, ii and iii
9. Draw the graph of the following inequalities:
- 1) $x - y > -10$ 2) $2x - y < 6$
3) $3x - y \geq 0$ 4) $3x - 2y \leq 12$
5) $y < -2$ 6) $x \geq 4$
7) $y > x + 2$ 8) $y < x + 2$
9) $y \geq 2x$ 10) $x + 3y < 0$
10. The air distance of the Singapore airport from the Hazrat Shahjalal airport is 2900 km. The maximum speed of the Bangladesh Biman is 500 km/hour. But on the way from the Hazrat Shahjalal airport, it faces air flowing at 60 km/hour from the opposite direction.
- 1) Express the problem of stimulus in terms of an inequality taking the required time as t hours.
- 2) Find the required time of non-stop flying from the Hazrat Shahjalal airport to the Singapore airport using the inequality in 10(1) and show it on a number line.
- 3) Take x as time of returning from the Singapore airport to the Hazrat Shahjalal airport and then express the problem in the form of an inequality and solve it graphically.
11. Between two numbers, the result of subtraction of 5 times of the second number from 3 times of the first one is greater than 5. Again, when 3 times of the second number is subtracted from the first one, the result is not more than 9.
- 1) Express the conditions stated by stimulus in the form of inequalities.
- 2) If 5 times of the first number is less than the sum of twice the first number and 15, express the possible values of the number in the form of an inequality.
- 3) Draw the graph of each pair of inequalities obtained in 1).
12. The sum of price of a pen, an eraser and a notebook is Tk. 100. Price of a notebook is more than the price of two pens. Price of three pens is more than the price of four erasers and price of three erasers is more than that of a notebook. If the price of all the commodities are in integers, what are the prices of each commodity?

13. The product of three integers is 720. What can be the maximum value of the smallest number?
14. If an isosceles triangle is divided into two isosceles triangles using the bisector of an angle of that triangle, what can be the maximum value of an angle of the first isosceles triangle? What can be the minimum value of an angle of the first isosceles triangle?
15. 7 tables, all of which have an area of one square meter can be placed in a rectangular room. If the perimeter of the room is 16 meters, what can be the length and the width of the room?
16. Is there any triangle whose height from the vertex can not be more than 1 cm but the area is 100 square?
17. Satej and Sajib are twin brothers. Their velocity in both running and walking are same. One day on the way to school, Satej passed half of the road by walking, while passed the rest by running. But Sajib passed half of the time by walking, while passed the rest by running. Will it take the same time for them to go to school?

Chapter 7

Infinite Series

Sequence and finite series are discussed in detail in the General Mathematics Book of Class IX-X. There is a direct relationship between sequence and infinite series. Infinite series can be obtained after assigning plus signs before the terms of a sequence. Infinite series will be discussed in this chapter.

After completing the chapter, the students will be able to –

- ▶ explain the idea of a sequence;
- ▶ identify the infinite series;
- ▶ explain the condition of existing the sum of an infinite geometric series;
- ▶ sum of an infinite geometric series;
- ▶ transform a recurring decimal number into an infinite geometric series and express in fraction.

Sequences

In the relationships illustrated below, every natural number n is related to its square n^2 ; that is, the set of square numbers $\{1, 4, 9, 16, \dots\}$ is obtained for the set of natural numbers $N = \{1, 2, 3, 4, \dots\}$ under a certain rule. This set of arranged sequence numbers is a sequence. When some numbers are arranged successively under a definite rule such that the relationship between any two successive terms is known, then the set of numbers arranged in this way is called a sequence.

1	2	3	4	...	n	...
↓	↓	↓	↓		↓	
1	4	9	16	...	n^2	...

The relationship shown above is called a function and is written as $f(n) = n^2$. The general term of this sequences is n^2 . The number of terms of any sequence is infinite. The way to write the sequence in terms of the general term is $\{n^2\}$, $n = 1, 2, 3, 4, \dots$ or, $\{n^2\}_{n=1}^{+\infty}$ or just, $\{n^2\}$. The first number of a sequences is called the first term, the second number of a sequences is called the second term and so

on. In the above sequence 1, 4, 9, 16, ..., first term = 1, second term = 4, and so on. Four more examples of sequences are given below:

- 1) $\frac{1}{2}, \frac{1}{2^2}, \frac{1}{2^3}, \frac{1}{2^4}, \dots, \frac{1}{2^n}, \dots$
- 2) $3, 1, -1, -3, \dots, (5 - 2n), \dots$
- 3) $1, \frac{2}{3}, \frac{3}{5}, \frac{4}{7}, \dots, \frac{n}{2n-1}, \dots$
- 4) $\frac{1}{2}, \frac{1}{5}, \frac{1}{10}, \frac{1}{17}, \dots, \frac{1}{n^2+1}, \dots$

Activity:

- 1) Find the general term of the following sequences:
 - (1) $\frac{1}{2}, -\frac{2}{3}, \frac{3}{4}, -\frac{4}{5}, \dots$
 - (2) $\frac{1}{2}, \frac{3}{4}, \frac{5}{6}, \frac{7}{8}, \dots$
 - (3) $\frac{1}{2}, \frac{1}{2}, \frac{3}{2^3}, \frac{4}{2^4}, \dots$
 - (4) $1, \sqrt{2}, \sqrt{3}, 2, \dots$
- 2) Write down the sequences from the given general terms:
 - (1) $1 + (-1)^n$
 - (2) $1 - (-1)^n$
 - (3) $1 + \left(-\frac{1}{2}\right)^n$
 - (4) $\frac{n^2}{\sqrt[3]{\pi}}$
 - (5) $\frac{\ln n}{n}$
 - (6) $\cos\left(\frac{n\pi}{2}\right)$
- 3) Write the general term of a sequence and then write the sequence.

Series

If the terms of a sequences are connected successively by a '+' sign, there a series is formed. As an example, $1 + 4 + 9 + 16 + \dots$ is a series. Then again, $\frac{1}{2} + \frac{1}{4} + \frac{1}{8} + \frac{1}{16} + \dots$ is another series. The ratio between two successive terms of this series is the same. This type of series is called **Geometric Series**. The characteristics of a series depends on the relationship between two consecutive terms of it. For example, in case of **Arithmetic Series**, the difference between two consecutive terms is constant.

Depending on the number of terms, series can be divided into two classes: 1) **Finite series** 2) **Infinite series** . Finite series are discussed in the General Mathematics Book of Class IX-X. Infinite series will be discussed here.

Infinite Series

If $u_1, u_2, u_3, \dots, u_n, \dots$ is a sequence of real numbers, then $u_1 + u_2 + u_3 + \dots + u_n + \dots$ is called an infinite series of real numbers. u_n is called the n -th term of this series.

Partial Sum of Infinite Series

Let $u_1 + u_2 + u_3 + \dots + u_n + \dots$ be an infinite series. Then its:

1st partial sum is $S_1 = u_1$

2nd partial sum is $S_2 = u_1 + u_2$

3rd partial sum is $S_3 = u_1 + u_2 + u_3$

\therefore The n -th partial sum is $S_n = u_1 + u_2 + u_3 + \dots + u_n$

That is, the n -th partial sum of an infinite series is the sum of the first n number of terms of the series, where $n \in N$.

Example 1. Find the partial sum of the following two series:

1) $1 + 2 + 3 + 4 + \dots$

2) $1 - 1 + 1 - 1 + \dots$

Solution:

1) First term of the $a = 1$ and common difference is $d = 1$. Therefore, the given series is an arithmetic progression.

Sum of the first n terms of the arithmetic series is

$$S_n = \frac{n}{2} \{2a + (n-1)d\} = \frac{n}{2} \{2 \cdot 1 + (n-1) \cdot 1\}$$

$$\text{So } S_n = \frac{n}{2} \{2 + n - 1\} = \frac{n(n+1)}{2}$$

In the above equation, putting different values of n we get,

$$S_{10} = \frac{10 \times 11}{2} = 55 \qquad S_{1000} = \frac{1000 \times 1001}{2} = 500500$$

$$S_{100000} = \frac{100000 \times 100001}{2} = 5000050000$$

Here as n increases, the value of S_n becomes larger.

Therefore, the given infinite series has no sum.

2) $1 - 1 + 1 - 1 + \dots$ is the given infinite series. Its

1st partial sum $S_1 = 1$

3rd partial sum $S_3 = 1 - 1 + 1 = 1$

2nd partial sum $S_2 = 1 - 1 = 0$

4th partial sum $S_4 = 1 - 1 + 1 - 1 = 0$

In the above example it can be seen that, for odd n , the n -th partial sum $S_n = 1$ and for even n , the n th partial sum $S_n = 0$.

Therefore, it is observed that there is no specific number which is the sum of this series.

Sum of Infinite Geometric Series

$a + ar + ar^2 + ar^3 + \dots$ is a geometric series. Its first term is a and common ratio is r .

Therefore, the n -th term of the series $= ar^{n-1}$, where $n \in N$

Now, if $r \neq 1$ then the partial sum of this series upto n -th term is

$$S_n = a + ar + ar^2 + ar^3 + \dots + ar^{n-1}$$

$$S_n = a \cdot \frac{r^n - 1}{r - 1} \quad \text{when } r > 1 \quad \text{and} \quad S_n = a \cdot \frac{1 - r^n}{1 - r} \quad \text{when } r < 1$$

We observe:

- 1) In the case of $|r| < 1$, that is $-1 < r < 1$, if the value of n increases (that is, when $n \rightarrow \infty$) then the value of $|r^n|$ decreases. Thus making n sufficiently large, the value can be decreased indefinitely, that is, $|r^n|$ approaches 0. So, the limiting value of $|r^n|$ becomes 0.

Consequently, the limiting value of S_n , $S_n = \frac{a(1 - r^n)}{1 - r} = \frac{a}{1 - r} - \frac{ar^n}{1 - r} = \frac{a}{1 - r}$

Therefore, the sum of the infinite series $S_\infty = \frac{a}{1 - r}$

- 2) In the case of $|r| > 1$, that is $r > 1$ or $r < -1$, if the value of n increases then the value of $|r^n|$ increases and making n sufficiently large the value of $|r^n|$ can be increased indefinitely. From this it is clear that there does not exist a finite number S which can be considered as the limiting value of S_n .

So, in this case, sum of the infinite series does not exist.

- 3) If $r = -1$, then the limiting value of S_n cannot be found. Because, if n is even then $(-1)^n = 1$ and if n is odd, then $(-1)^n = -1$. In this case the series will be, $a - a + a - a + a - a + \dots$

So, sum of this infinite series does not exist.

- 4) In case of $r = 1$, limiting value of S_n cannot be found as well. Because, in that case the series will be $a + a + a + a + \dots$ (n numbered). That means, $S_n = na$ which can be increased with the increasing of n .

So, sum of this infinite series does not exist.

If $|r| < 1$, that is $-1 < r < 1$, then the sum of the infinite series $a + ar + ar^2 + \dots$, $S = \frac{a}{1-r}$. For other values of r , the sum of the series does not exist.

Remark: The sum of the infinite geometric series (if exists) is sometimes denoted by S_∞ and it is called the sum of the series up to infinity. That is, $a + ar + ar^2 + ar^3 + \dots$ up to infinity, $S_\infty = \frac{a}{1-r}$, when $|r| < 1$.

Activity:

- 1) In each case below, the first term a and the common ratio r of an infinite series are given. Write down the series and find the sum if it exists:
- (1) $a = 4, r = \frac{1}{2}$ (2) $a = 2, r = -\frac{1}{3}$ (3) $a = \frac{1}{3}, r = 3$
 (4) $a = 5, r = \frac{1}{10^2}$ (5) $a = 1, r = -\frac{2}{7}$ (6) $a = 81, r = -\frac{1}{3}$
- 2) Every one of you, write an infinite series.

Example 2. Find the sum (if it exists) of each of the following infinite geometric series:

- 1) $\frac{1}{3} + \frac{1}{3^2} + \frac{1}{3^3} + \frac{1}{3^4} + \dots$
 2) $1 + 0.1 + 0.01 + 0.001 + \dots$
 3) $1 + \frac{1}{\sqrt{2}} + \frac{1}{2} + \frac{1}{2\sqrt{2}} + \frac{1}{4} + \dots$

Solution:

- 1) Here, the first term of the series, $a = \frac{1}{3}$ and common ratio, $r = \frac{1}{3^2} \times \frac{3}{1} = \frac{1}{3} < 1$

\therefore The sum to infinity of the series is, $S_\infty = \frac{a}{1-r} = \frac{\frac{1}{3}}{1-\frac{1}{3}} = \frac{1}{3} \times \frac{3}{2} = \frac{1}{2}$

2) The first term of the series, $a = 1$ and common ratio, $r = \frac{0.1}{1} = \frac{1}{10} < 1$

$$\therefore \text{The sum to infinity of the series is, } S_{\infty} = \frac{a}{1-r} = \frac{1}{1-\frac{1}{10}} = \frac{10}{9} = 1\frac{1}{9}$$

3) Here, the first term of the series, $a = 1$ and common ratio, $r = \frac{1}{\sqrt{2}} = \frac{1}{\sqrt{2}} < 1$

$$\therefore \text{The sum to infinity of the series is, } S_{\infty} = \frac{a}{1-r} = \frac{1}{1-\frac{1}{\sqrt{2}}} = \frac{\sqrt{2}}{\sqrt{2}-1} = 3.414 \text{ (approx.)}$$

Transformation of Repeating (or Recurring) Decimals in Rational Fractions

Example 3. Express in rational fractions of the following repeating decimals:

1) $0.\dot{5}$

2) $0.\dot{1}\dot{2}$

3) $1.\dot{2}\dot{3}\dot{1}$

Solution:

1) $0.\dot{5} = 0.555\dots = 0.5 + 0.05 + 0.005 + \dots$

This infinite geometric series goes with the first term, $a = 0.5$ and common ratio, $r = \frac{0.05}{0.5} = 0.1$

$$\therefore 0.\dot{5} = \frac{a}{1-r} = \frac{0.5}{1-(0.1)} = \frac{0.5}{0.9} = \frac{5}{9}$$

2) $0.\dot{1}\dot{2} = 0.121212\dots = 0.12 + 0.0012 + 0.000012 + \dots$

The first term of this infinite geometric series, $a = 0.12$ and common ratio, $r = \frac{0.0012}{0.12} = 0.01$

$$\therefore 0.\dot{1}\dot{2} = \frac{a}{1-r} = \frac{0.12}{1-(0.01)} = \frac{0.12}{0.99} = \frac{4}{33}$$

3) $1.\dot{2}\dot{3}\dot{1} = 1.231231231\dots = 1 + (0.231 + 0.000231 + 0.000000231 + \dots)$

Here, the series in the parentheses is an infinite geometric series.

Its first term, $a = 0.231$ and common ratio, $r = \frac{0.000231}{0.231} = 0.001$

$$\therefore 1.\dot{2}\dot{3}\dot{1} = 1 + \frac{a}{1-r} = 1 + \frac{0.231}{1-(0.001)} = 1 + \frac{231}{999} = \frac{410}{333}$$

Example 4. $\frac{1}{2x+1} + \frac{1}{(2x+1)^2} + \frac{1}{(2x+1)^3} + \dots$ is an infinite geometric series.

- 1) If $x = 1$, then determine the common ratio of the series.
- 2) If $x = \frac{3}{2}$, then determine the 5th term and sum upto the 10th term of the series.
- 3) If the series has sum to infinity, then what condition should be imposed upon x ? Determine that sum.

Solution:

- 1) Given that, $\frac{1}{2x+1} + \frac{1}{(2x+1)^2} + \frac{1}{(2x+1)^3} + \dots$ is an infinite geometric series.

$$\begin{aligned} \text{If } x = 1, \text{ the series} &= \frac{1}{2 \cdot 1 + 1} + \frac{1}{(2 \cdot 1 + 1)^2} + \frac{1}{(2 \cdot 1 + 1)^3} + \dots \\ &= \frac{1}{3} + \frac{1}{3^2} + \frac{1}{3^3} + \dots \end{aligned}$$

$$\text{Its common ratio, } r = \frac{\frac{1}{3^2}}{\frac{1}{3}} = \frac{1}{3}$$

- 2) Given that, $\frac{1}{2x+1} + \frac{1}{(2x+1)^2} + \frac{1}{(2x+1)^3} + \dots$

$$\begin{aligned} \text{If } x = \frac{3}{2}, \text{ the series} &= \frac{1}{2 \cdot \frac{3}{2} + 1} + \frac{1}{(2 \cdot \frac{3}{2} + 1)^2} + \frac{1}{(2 \cdot \frac{3}{2} + 1)^3} + \dots \\ &= \frac{1}{4} + \frac{1}{4^2} + \frac{1}{4^3} + \dots \end{aligned}$$

$$\text{The first term of the series, } a = \frac{1}{4} \text{ common ratio, } r = \frac{\frac{1}{4^2}}{\frac{1}{4}} = \frac{1}{4} < 1$$

$$\therefore \text{5th term of the series} = ar^{5-1} = \frac{1}{4} \cdot \left(\frac{1}{4}\right)^{5-1} = \left(\frac{1}{4}\right)^5 = \frac{1}{4^5}$$

$$\text{Sum of first 10 terms of the series} = \frac{a(1-r^n)}{1-r} \quad [n = 10]$$

$$= \frac{\frac{1}{4} \left\{ 1 - \left(\frac{1}{4} \right)^{10} \right\}}{1 - \frac{1}{4}} = \frac{\frac{1}{4} \left(1 - \frac{1}{4^{10}} \right)}{\frac{3}{4}} = \frac{1}{4} \times \frac{4}{3} \left(1 - \frac{1}{4^{10}} \right) = \frac{1}{3} \left(1 - \frac{1}{4^{10}} \right)$$

3) First term of the series, $a = \frac{1}{2x+1}$, Common ratio, $r = \frac{(2x+1)^2}{1} = \frac{1}{2x+1}$

Here, $\frac{1}{2x+1} \neq 0$, So, $\frac{1}{2x+1} > 0$ or $\frac{1}{2x+1} < 0 \dots (1)$

Now, the series will have sum to infinity if, $|r| < 1$ that is $\left| \frac{1}{2x+1} \right| < 1$
 $\dots (2)$

When condition of (1) $\frac{1}{2x+1} > 0$ is true, that is $2x+1 > 0$ [multiplicative reciprocal has the same sign] then putting it in (2), we get $\frac{1}{2x+1} < 1$

Now, multiplying both sides with positive number $2x+1$ will keep the inequality sign same

$$\text{that is } 1 < 2x+1, \quad \text{or, } 1-1 < 2x, \quad \text{or, } 0 < 2x, \quad \text{or, } 2x > 0 \quad \text{or, } x > 0$$

When condition of $\frac{1}{2x+1} < 0$ is true, that is $2x+1 < 0$ [

then putting it in (2), we get $-\frac{1}{2x+1} < 1$

Now if we multiply both sides with negative number $2x+1$, then the inequality sign will reverse

$$\text{that is } -1 > 2x+1, \quad \text{or, } -1-1 > 2x, \quad \text{or, } -2 > 2x, \quad \text{or, } -1 > x, \\ \text{or, } x < -1$$

\therefore the condition is $x < -1$ or, $x > 0$

$$\text{So the sum to infinity of the series, } S_{\infty} = \frac{a}{1-r} = \frac{\frac{1}{2x+1}}{1 - \frac{1}{2x+1}}$$

$$\text{Multiplying the nominator and denominator by } (2x+1), S_{\infty} = \frac{1}{2x+1-1} = \frac{1}{2x}$$

Exercise 7

- What is the 12th term of the series 1, 3, 5, 7, ...?
 - 12
 - 13
 - 23
 - 25
- What is the 3rd term of a sequence whose n th term = $\frac{1}{n(n+1)}$?
 - $\frac{1}{3}$
 - $\frac{1}{6}$
 - $\frac{1}{12}$
 - $\frac{1}{20}$
- What is the 20th term of a sequence whose n th term = $\frac{1 - (-1)^n}{2}$?
 - 0
 - 1
 - 1
 - 2
- The n th term of a sequence is $u_n = \frac{1}{n}$ and $u_n < 10^{-4}$. The value of n is
 - $n < 10^3$
 - $n < 10^4$
 - $n > 10^4$

Which one is true?

- iii*
 - i, iii*
 - ii, iii*
 - i, ii, iii*
- If the n th term of a sequence is $u_n = 1 - (-1)^n$, then its
 - 10th term is 0
 - 15th term is 2
 - sum of first 12 terms is 12

Which one of the followings is true?

- i, ii*
 - i, iii*
 - ii, iii*
 - i, ii, iii*

Observe the following series and answer the question (6-8)

$$4 + \frac{4}{3} + \frac{4}{9} + \dots$$

- What is the 10th term of the series?
 - $\frac{4}{3^{10}}$
 - $\frac{4}{3^9}$
 - $\frac{4}{3^{11}}$
 - $\frac{4}{3^{12}}$
- What is the sum of first 5 terms of the series?
 - $\frac{160}{27}$
 - $\frac{484}{81}$
 - $\frac{12}{9}$
 - $\frac{20}{9}$
- What is the sum of the series upto infinity?
 - 0
 - 5
 - 6
 - 7
- Find the 10th term, 15th term and r th term of the given sequences:
 - 2, 4, 6, 8, 10, 12, ...

- 2) $\frac{1}{2}, 1, \frac{3}{2}, 2, \frac{5}{2}, \dots$
- 3) The n th term of the sequence $= \frac{1}{n(n+1)}, n \in N$
- 4) $0, 1, 0, 1, 0, 1, \dots$
- 5) $5, \frac{5}{3}, \frac{5}{9}, \frac{5}{27}, \frac{5}{81}, \dots$
- 6) The n th term of the sequence $= \frac{1 - (-1)^{3n}}{2}$
10. The n th term of a sequence is $u_n = \frac{1}{n}$
- 1) If $u_n < 10^{-5}$, what will be the value of n ?
 - 2) If $u_n > 10^{-5}$, what will be the value of n ?
 - 3) What can be said about the limiting value of u_n (when n is sufficiently large)?
11. Find the sum of the given series (up to infinity) if exists:
- 1) $1 + \frac{1}{2} + \frac{1}{4} + \frac{1}{8} + \dots$
 - 2) $\frac{1}{5} - \frac{2}{5^2} + \frac{4}{5^3} - \frac{8}{5^4} + \dots$
 - 3) $8 + 2 + \frac{1}{2} + \frac{1}{8} + \frac{1}{32} + \dots$
 - 4) $1 + 2 + 4 + 8 + 16 + \dots$
 - 5) $\frac{1}{2} + \left(-\frac{1}{4}\right) + \frac{1}{8} + \left(-\frac{1}{16}\right) + \dots$
12. Find the sum of first n terms of the series given below:
- 1) $7 + 77 + 777 + \dots$
 - 2) $5 + 55 + 555 + \dots$
13. Impose a condition on x under which the infinite series $\frac{1}{x+1} + \frac{1}{(x+1)^2} + \frac{1}{(x+1)^3} + \dots$ will have a sum (to infinity) and find that sum.
14. Express each of the given repeating decimals as a rational fraction:
- 1) $0.\dot{2}\dot{7}$
 - 2) $2.\dot{3}0\dot{5}$
 - 3) $0.0\dot{1}2\dot{3}$
 - 4) $3.0\dot{4}0\dot{3}$
15. $a + ab + ab^2 + \dots$ is a geometric series.

- 1) What is the 7th term of the series?
 - 2) If $a = 1$ and $b = \frac{1}{2}$, determine the sum to infinity of the series if exists.
 - 3) Determine the sum of first n terms of the series which is found by placing 3 in stead of a , 33 in stead of ab and 333 in stead of ab^2 .
16. The sum of three consequent terms of a geometric series is $24\frac{4}{5}$ and multiplication is 64.
- 1) Construct two equations based on the given information.
 - 2) Determine the first term and the common ratio.
 - 3) If the common ratio is $\frac{1}{5}$, then determine the sum to infinity of the series.
17. There are four dogs standing in the four corners of a square area, each side of which is 1 km. Now, every dog runs blindly towards the dog on its right in the same velocity, covering half the distance. After opening the eyes, they run similarly to the dog on its right again, covering half the distance.
- 1) If they continue to run like this, what will be the terminal position of the dogs? How much distance each will cross?
 - 2) Answer the previous question if after covering half the distance, without changing direction each dog covers additional $1/k$ times of the distance and then changes direction.
 - 3) Answer both the questions stated above if the area was not a square, rather an equilateral triangle.

Chapter 8

Trigonometry

The word Trigonometry has been derived from the words ‘Trigon’ and ‘Metry’. ‘Trigon’ is a Greek word which means three angles and ‘Metry’ means measure. In general **Trigonometry** means the measurement of three angles of a triangle. For practical purposes, trigonometry was introduced from for the measurement of three angle and three sides of a triangle and from their related ideas. For example, the use of trigonometry in measuring the height of the tree with the help of its shadow, determining the width of a river by standing on its bank, determining the area of a triangular land etc. is very ancient and popular. Besides, trigonometry is extensively used in every branches of mathematics and science. That is why trigonometry is well established as a very important topic in mathematics. Trigonometry has two branches; one is **Plane Trigonometry**, the other is **Spherical Trigonometry**. We are concerned with plane trigonometry only.

After completing the chapter, the students will be able to –

- ▶ explain the concept of radian measurement;
- ▶ determine the relation between radian measurement and degree measurement;
- ▶ indicate trigonometrical ratios and their signs in the quadrant;
- ▶ find the trigonometrical ratios of standard angles and associated angles upto 2π ;
- ▶ find the trigonometrical ratios of angle $-\theta$;
- ▶ find the trigonometrical ratios of angle $\frac{n\pi}{2} \pm \theta$ and apply for integer $n \leq 4$;
- ▶ solve simple trigonometrical equation.

Angles in Geometry and in Trigonometry

For the convenience of discussion of angles in geometry and trigonometry, let us draw a pair of mutually perpendicular straight lines XOX' and YOY' at the plane XY . In the following figure as the lines bisect at the point O , each of the regions included between the four right-angles is called a **Quadrant**. By moving anti-clockwise from the line OX , the first region enclosed by ($\angle XOY$ 1 right angle) is called **First quadrant** and by moving accordingly region enclosed by second ($\angle YOX'$), third ($\angle X'OY'$) and fourth ($\angle XOY'$) right angles are called **second, third and fourth quadrant** (Following figure).

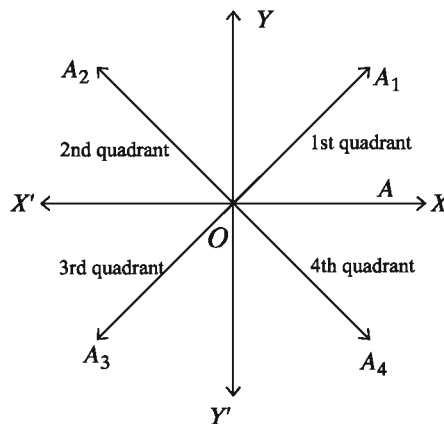

In geometry angle is formed by two rays meeting at a point. In trigonometry an angle is produced by a revolving ray about a fixed ray. Let, OA is a revolving ray and at the beginning it revolve anticlockwise from the fixed ray OX . The ray OA at first form acute angle $\angle XO A_1$ at the position OA_1 and remain in the first quadrant and then when it come to the position perpendicular to OY with OX , the measurement of $\angle XOY$ become 90° or 1 right angle. By more revolving at the same direction when the ray OA comes to the position OA_2 , then it forms an obtuse angle $\angle XO A_2$. By more revolving at same direction when the ray OA comes to the opposite of the ray OX at the position of OX' , then the angle $\angle XO X'$ is formed is a straight angle or 2 right angle. By complete revolving when the ray OA comes to previous position that is merge with OX , then the angle formed is 2 straight angle or 4 right angle.

In geometry angles are limited to 180° , and there is no difference between geometric and trigonometric angles in this case. If we consider that the ray OA revolves further to reach OA_1 after completing a round then the angle formed

XOA_1 becomes greater than 4 right angles. The angle $\angle XOX$ created by the original position of the ray OA is not considered as a geometric angle, but it is considered an angle in trigonometry.

Positive and negative angle

In the above discussion, the ray OA (above figure) has been revolved anticlockwise and the angles formed by OA at different quadrant was considered as positive angles. Therefore, an angle produced by anti-clockwise revolving is considered **positive** and an angle produced by clockwise revolving is considered **negative**.

So, from the above discussion it can be said that, when the positive angle is less than 90° then it remains in first quadrant. Again, the angle will also be in first quadrant if the value is between 360° and 450° . Similarly, if the value of a positive angle is between 180° and 270° then it will remain in the third quadrant, if from 90° to 180° then in the second quadrant and between 270° and 360° then it will be in fourth quadrant. Likewise, if the value of a negative angle is from -90° to 0° then it will remain in the fourth quadrant, from -180° to -90° in the third quadrant, from -270° to -180° in the second quadrant and from -360° to -270° in the first quadrant. 180° and 360° or any integer multiplicand of them coincides with the straight line XOX' and 90° and 270° or any integer multiplicand of them coincides with the straight line YOY' (see the adjacent figure). $\angle AOA_1$ in first quadrant, $\angle AOA_2$ in second quadrant, $\angle AOA_3$ in third quadrant and $\angle AOA_4$ in the fourth quadrant.

Example 1. In which quadrants do the angles 1) 430° and 2) 545° lie ?

- 1) $430^\circ = 360^\circ + 70^\circ = 4 \times 90^\circ + 70^\circ$ 430° is a positive angle and 4 is greater than the right angle but 5 is less than right angle. Therefore, to produce the angle 430° any ray have to rotate 4 right angle or have to revolve one full rotation and 70° more (Following figure at left). So, the angle 430° lies in the first quadrant.

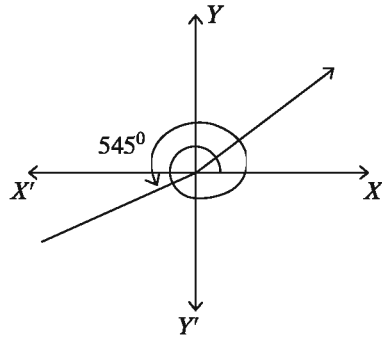
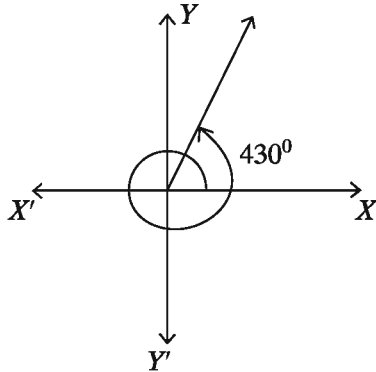

- 2) $545^\circ = 540^\circ + 5^\circ = 6 \times 90^\circ + 5^\circ$ 545° is a positive angle and 6 is greater than right angle but 7 is less than right angle. To produce the angle 545° any ray have to rotate 6 right angle and 5° in the anticlockwise direction or two right angle and 5° after the full rotation (Above figure in left). So, the angle 545° lies in the third quadrant.

Activity: Determine in which quadrant each of the following angle lie: 330° , 535° , 777° and 1045° ; draw pictures.

Example 2. In which quadrants do the angles 1) -520° and 2) -750° lie?

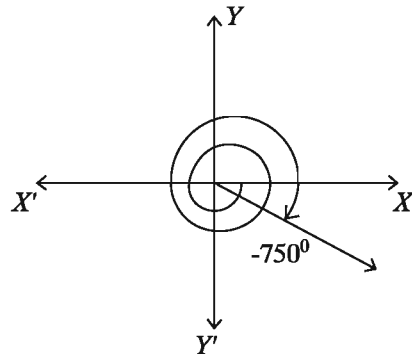
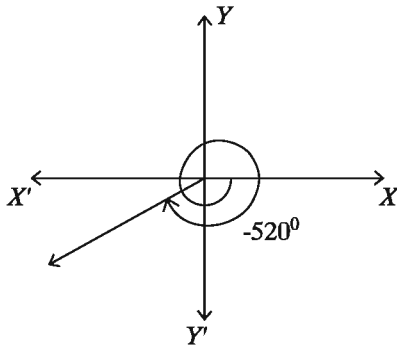

- 1) $-520^\circ = -450^\circ - 70^\circ = -5 \times 90^\circ - 70^\circ$ -520° is a negative angle and to produce the angle -520° any ray have to rotate one right angle or 90° and 70° more in the same direction after the full rotation in clockwise direction to some to the third quadrant (Above figure in left). Therefore, the angle -540° lies in the third quadrant.
- 2) $-750^\circ = -720^\circ - 30^\circ = -8 \times 90^\circ - 30^\circ$ -750° is a negative angle and have to rotate 30° more after the full rotation twice (8 right angle) (Above figure in right). Therefore, the angle -750° lies in the fourth quadrant.

Work: Determine in which quadrant each of the angles below lie: -100° , -365° , -720° and 1320° Draw pictures.

Measurement of Angles

To measure any angle we use two unit systems :

- 1) Sexagesimal System and
- 2) Circular System

Sexagesimal System: In this system right angle is considered as unit of measurement of angle. In this system one degree is one – ninetieth 90 part of a right angle one metre ($1^\circ =$ one degree).

One-minute is one sixtieth 60 part of one degree i.e., ($1' =$ one minute) and that of one-second is one sixtieth 60 part of one minute i.e., ($1'' =$ one second).

That is, $60''$ (second) = $1'$ (minute)

$60'$ (minute) = 1° (degree)

90° (degree) = 1 right angle

Radian system is necessary to know before circular system.

Radian: In any circle the angle which an arc of the circle whose length is equal to the radius of the circle subtends at the centre, is called one radian.

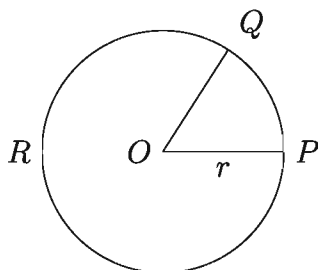

In the figure, the centre of circle PQR is O , radius $OP = r$ and PQ is an arc equal to the radius. Arc PQ produce angle $\angle POQ$ at the centre O . This measurement of that angle is called radian i.e. $\angle POQ$ is a radian.

Circular System: In circular system one radian angle is considered as measurement unit of angle. To determine the relation between radian

measurement and degree measurement the following proposition need to be known.

Proposition 1. In any two circles the ratios of the circumferences and the respective diameters and equal.

Proof: We can assume that the circles have the same centre O and they are concentric. Let p and r denote the circumference and radius of the inner (smaller) circle and P and R denote the circumference and radius of the outer (greater) circle (following figure). We divide the circumference of the outer circle into n equal arcs where ($n > 1$). Joining the dividing points with centre the inner circle also divided into n equal parts. Let us join the dividing points of both the circles. We get consequently (outer circle $ABCD \dots$ and inner circle $abcd \dots$) two n sided regular polygons inscribed in the outer and inner circle, respectively.

Now, $\triangle OAB$ and $\triangle Oab$ are similar, because, $\angle AOB$ and $\angle aOb$ [common angle] and being isosceles triangles, their other two angles are equal.

$$\therefore \frac{AB}{ab} = \frac{OA}{Oa} = \frac{OB}{Ob} = \frac{R}{r}$$

Similarly,

$$\frac{BC}{bc} = \frac{R}{r}, \frac{CD}{cd} = \frac{R}{r} \text{ etc.}$$

$$\therefore \frac{AB}{ab} = \frac{BC}{bc} = \frac{CD}{cd} = \dots = \frac{R}{r}$$

$$\therefore \frac{AB + BC + CD + \dots}{ab + bc + cd + \dots} = \frac{R + R + R + \dots}{r + r + r + \dots} = \frac{nR}{nr} = \frac{R}{r} = \frac{2R}{2r} \dots (1)$$

If n is sufficiently large that is letting ($n \rightarrow \infty$), then AB, BC, CD, \dots will be very small and seems to be minute arcs of the circle.

Therefore, in this case, $AB + BC + CD + \dots \approx$ circumference of the outer circle P and

$ab + bc + cd + \dots \approx$ circumference of the inner circle p

\therefore from equation (1) we get,

$$\frac{P}{p} = \frac{2R}{2r}$$

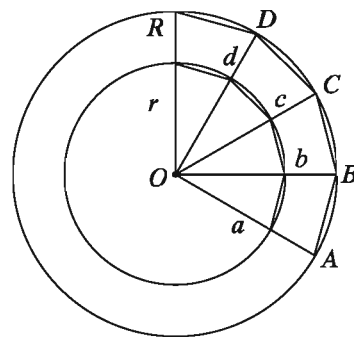

$$\text{i.e., } \frac{P}{2R} = \frac{p}{2r}$$

$$\text{i.e., } \frac{\text{circumference of the outer circle}}{\text{diameter of the outer circle}} = \frac{\text{circumference of the inner circle}}{\text{diameter of the inner circle}}$$

\therefore In any circle the circumference bears a constant ratio to its diameter.

By Corollary 1:

Remark: In any circle the circumference bears a constant ratio to its diameter. This constant ratio is denoted by the Greek letter π (pi). π is an irrational number and expressing in decimal places it will be non-terminating where, ($\pi = 3.1415926535897932\dots$).

Remark: Generally approximate value of π upto four decimal places is used where $\pi = 3.1416$. Using computer the value of π has been determined upto millions and millions of digit in decimal place. As we use approximate value of π , answer must be approximated. That is why it is required to write 'approx' beside the answer. Approximate value of $\pi = 3.1416$ will be used as no direction is mentioned.

Corollary 2. The circumference of any circle of radius r is equal to $2\pi r$.

Proof: By Corollary 1 we know,

$$\frac{\text{Circumference}}{\text{Diameter}} = \pi$$

or, Circumference = $\pi \times$ Diameter

$$= \pi \times 2r \text{ [Diameter} = 2r\text{]}$$

$$= 2\pi r$$

\therefore Circumference of any circle of radius r is $2\pi r$.

Proposition 3. The centred angle produced by any arc of a circle is proportional to its arc.

Let O be the centre and OB is radius of the circle ABC . P is another point on the circle. So BP is an arc and $\angle POB$ is the centred angle of the circle. So centred angle $\angle POB$ is proportional to arc BP .

i.e. centred angle $\angle POB \propto$ arc BP .

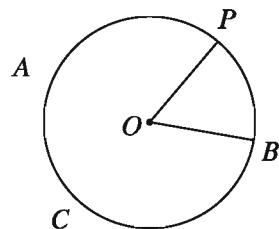

Proposition 4. Radian is a constant angle.

Particular Enunciation : Suppose in the circle ABC with the centre O , $\angle P, B$ is a radian angle. Prove that $\angle POB$ is a constant angle.

Construction : Draw perpendicular OA upon the segment OB (radius).

Proof:

OA intersect the circumference at A .

Arc AB = one-fourth of the circumference = $\frac{1}{4} \times$

$$2\pi r = \frac{\pi r}{2}$$

And arc PB = radius r [$\angle POB = 1$ radian]

From corollary 3,

$$\frac{\angle POB}{\angle AOB} = \frac{\text{Arc}PB}{\text{Arc}AB}$$

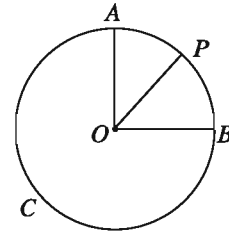

$$\therefore \angle POB = \frac{\text{Arc}PB}{\text{Arc}AB} \times \angle AOB = \frac{r}{\frac{\pi r}{2}} \times 1 \text{ right angle [Radius } OA \text{ is perpendicular}$$

to OB]

$$= \frac{2}{\pi} \text{ right angle.}$$

As the right angle and π are constant, $\angle POB$ is a constant angle.

Circular measurement of angle

Definition 1. By circular system i.e., The measure of an angle in the radian unit is called its radian measure or circular measure.

Suppose $\angle MON$ is a given angle. With centre O we draw a circle of suitable radius $OA = r$. Suppose the circle intersects the sides OM and ON of the angle at A and B , respectively. So constructed angle $\angle AOB$ is a centred angle produced by arc AB . Taking an arc AP equal to radius r (arc and radius should have same unit).

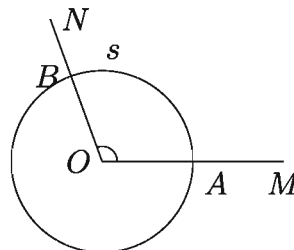
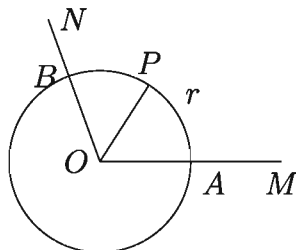

Then $\angle AOP = 1$ radian

Suppose arc $AB = s$.

From proposition 3,

$$\frac{\angle MON}{\angle AOP} = \frac{\text{Arc}AB}{\text{Arc}AP} = \frac{\text{Arc}AB}{\text{Radius}OA} = \frac{s}{r}$$

$$\begin{aligned} \therefore \angle MON &= \frac{s}{r} \times \angle AOP \\ &= \frac{s}{r} \times 1 \text{ radian} = \frac{s}{r} \text{ radian} \end{aligned}$$

\therefore Circular measure of $\angle MON$ is $\frac{s}{r}$, where the angle cut arc s centring its vertex and taking r as radius of the circle.

Proposition 5. Any arc of length s produces an angle θ in the centre of the circle of radius r then $s = r\theta$.

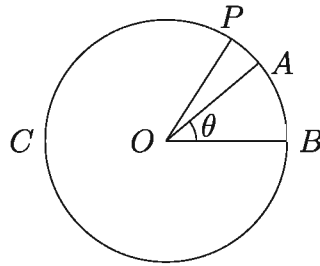

Particular enunciation : Let O is the centre and $OB = r$ unit is the radius of the circle ABC , arc $AB = s$ unit and centred angle $\angle AOB = \theta^c$ produced by the arc AB . It is to prove that, $s = r\theta$.

Construction : Draw the arc BP equal to radius OB at the point B so that it intersects the circle ABC at P . Join O, P .

Proof: By construction $\angle POB = 1^c$

We know, centred angle produced by any arc is proportional to arc.

$$\frac{\text{Arc } AB}{\text{Arc } PB} = \frac{\angle AOB}{\angle POB}$$

$$\text{or, } \frac{s \text{ unit}}{r \text{ unit}} = \frac{\theta^c}{1^c}$$

$$\text{or, } \frac{s}{r} = \theta$$

$\therefore s = r\theta$ (Proved)

Relation between the degree and radian (circular) measure

We know from proposition 4,

$$1 \text{ radian} = \frac{2}{\pi} \text{ right angle}$$

$$\text{i.e., } 1^c = \frac{2}{\pi} \text{ right angle. [1 radian} = 1^c]$$

$$\therefore 1 \text{ right angle} = \left(\frac{\pi}{2}\right)^c$$

$$\text{or, } 90^\circ = \left(\frac{\pi}{2}\right)^c$$

$$\therefore 1^\circ = \left(\frac{\pi}{180}\right)^c \text{ and } 1^c = \left(\frac{180}{\pi}\right)^\circ$$

Proposition 6. $1^\circ = \left(\frac{\pi}{180}\right)^c$ and $1^c = \left(\frac{180}{\pi}\right)^\circ$

Observation :

$$(i) 90^\circ = 1 \text{ right angle} = \frac{\pi}{2} \text{ radian} = \left(\frac{\pi}{2}\right)^c$$

$$\text{i.e., } 180^\circ = 2 \text{ right angle} = \pi \text{ radian} = \pi^c.$$

(ii) If D° and R^c be the measurement of an angle in sexagesimal and circular system then

$$D^\circ = \left(D \times \frac{\pi}{180}\right)^c = R^c$$

$$\text{i.e., } D \times \frac{\pi}{180} = R$$

$$\text{or, } \frac{D}{180} = \frac{R}{\pi}.$$

From the above discussion the widely use of the relation between degree and radian measures are given below:

$$(i) 1^\circ = \left(\frac{\pi}{180}\right)^c$$

$$(ii) 30^\circ = \left(30 \times \frac{\pi}{180}\right)^c = \left(\frac{\pi}{6}\right)^c$$

$$(iii) 45^\circ = \left(45 \times \frac{\pi}{180}\right)^c = \left(\frac{\pi}{4}\right)^c$$

$$(iv) 60^\circ = \left(60 \times \frac{\pi}{180}\right)^c = \left(\frac{\pi}{3}\right)^c$$

$$(v) 90^\circ = \left(90 \times \frac{\pi}{180}\right)^c = \left(\frac{\pi}{2}\right)^c$$

$$(vi) 180^\circ = \left(180 \times \frac{\pi}{180}\right)^c = \pi^c$$

$$(vii) 360^\circ = \left(360 \times \frac{\pi}{180}\right)^c = (2\pi)^c$$

In all practical purposes the radian symbol (c) is silent.

$$1^\circ = \frac{\pi}{180}, 30^\circ = \frac{\pi}{6}, 45^\circ = \frac{\pi}{4}, 60^\circ = \frac{\pi}{3}, 90^\circ = \frac{\pi}{2}, 180^\circ = \pi, 360^\circ = 2\pi \text{ etc.}$$

Note: $1^\circ = \left(\frac{\pi}{180}\right)^c = 0.01745^c$ (nearly)

$$1^c = \left(\frac{180}{\pi}\right)^\circ = 57.29578^\circ \text{ (nearly)} = 57^\circ 17' 44.81''.$$

Here the approximate value of π is 3.1416

Note: We shall use this approximate value of π ($\pi = 3.1416$) in all examples and exercises. When ever an approximate value of π is used the word 'nearly' must be affixed to the result.

Example 3. 1) Express $30^\circ 12' 36''$ in radians. 2) Express $\frac{3\pi}{13}$ in degree, minute and seconds.

Solution:

$$1) 30^\circ 12' 36'' = 30^\circ \left(12 \frac{36}{60}\right)' = 30^\circ \left(12 \frac{3}{5}\right)' = 30^\circ \left(\frac{63}{5}\right)'$$

$$= \left(30 \frac{63}{5 \times 60}\right)^\circ = \left(30 \frac{21}{100}\right)^\circ = \left(\frac{3021}{100}\right)^\circ$$

$$= \frac{3021}{100} \times \frac{\pi}{180} \text{ radian } [\because 1^\circ = \frac{\pi^c}{180}]$$

$$= \frac{3021\pi}{18000} = .5273 \text{ radian (nearly)}$$

$$\therefore 30^\circ 12' 36'' = .5273^c \text{ (nearly)}$$

$$2) \frac{3\pi}{13} = \frac{3\pi}{13} \times \frac{180}{\pi} \text{ degree } [\because 1^c = \left(\frac{180}{\pi}\right)^\circ]$$

$$= \frac{540}{13} \text{ degree} = 41^\circ 32' 18.46''.$$

$$\therefore \frac{3\pi}{13} \text{ radian} = 41^\circ 32' 18.46''$$

Example 4. The measures of the three angles of a triangle are in the ratio 3 : 4 : 5, Find the circular measures of the angles.

Solution: Suppose the angles are $3x^c$, $4x^c$ and $5x^c$, respectively.

In the circular measure, $3x^c + 4x^c + 5x^c = \pi^c$ [The sum of the three angles of any triangle 2 right angles = π^c]

$$\text{or, } 12x^c = \pi^c$$

$$\text{or, } x = \frac{\pi}{12}$$

\therefore the three angles are :

$$3x^c = \left(\frac{3\pi}{12}\right)^c = \left(\frac{\pi}{4}\right)^c = \frac{\pi}{4}$$

$$4x^c = \left(\frac{4\pi}{12}\right)^c = \left(\frac{\pi}{3}\right)^c = \frac{\pi}{3}$$

$$5x^c = \left(\frac{5\pi}{12}\right)^c = \frac{5\pi}{12}$$

So, the circular value of the three angles are: $\frac{\pi}{4}$, $\frac{\pi}{3}$ and $\frac{5\pi}{12}$

Example 5. A giant wheel makes 40 revolutions to cover a distance of 1.75 kilometer. What is the radius of the wheel ?

Solution: Suppose the radius of the wheel is r metre.

\therefore the circumference of the wheel = $2\pi r$ metre [$\pi = 3.1416$]

We know in one revolution the wheel covers a distance equal to its circumference.

\therefore In 40 revolutions the wheel covers = $40 \times 2\pi r$ m. = $80\pi r$ metre

As per the question, $80\pi r = 1750$ [1 kilometre = 1000 metre]

$$\text{or, } r = \frac{1750}{80\pi} = \frac{1750}{80 \times 3.1416} \text{ metre.}$$

$$= 6.963 \text{ metre (nearly).}$$

\therefore the radius of the wheel is 6.963 metre (nearly).

Example 6. Radius of the earth is 6440 kilometre. If the arc on the surface of the earth joining Dhaka with Jamalpur subtends an angle of 2° at the centre of the earth, find the distance between Dhaka and Jamalpur.

Solution: Radius = $r = 6440$ k.m.

The angle made in the centre of the earth $\theta = 2^\circ = 2 \times \frac{\pi^c}{180} = \frac{\pi}{90}$ radian.

$\therefore s =$ length of the arc = distance between Dhaka and Jamalpur = $r\theta = 6440 \times \frac{\pi}{90}$ k.m.

$$= \frac{644\pi}{9} \text{ k.m.}$$

$$= 224.8 \text{ k.m. (nearly)}$$

Determinable distance: 224.8 k.m. (nearly).

Example 7. Find the circular measure of the angle subtended by an arc of length 11 c.m. at the centre of a circle radius 7 c.m.

Solution: Suppose the radius $OB = 7$ c.m. and arc $AB = 11$ c.m. of the circle ABC . It is to determine the value of the angle θ that makes the circular angle with the arc AB .

We know, $s = r\theta$

$$\text{or, } \theta = \frac{s}{r} = \frac{11 \text{ c.m.}}{7 \text{ c.m.}}$$

$$= 1.57 \text{ radian (nearly)}$$

The value of the determinable angle : 1.57 radian (nearly).

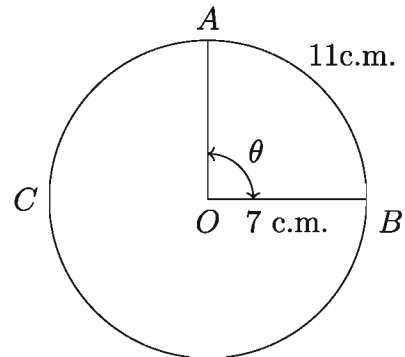

Example 8. Ehsan traverses the arc in 10 seconds by riding a cycle. If an arc of the circular path subtends an angle of 28° at the centre and the diameter of the circular path is 180 metre, then find the speed of Ehsan.

Solution: Let us assume that starting at B of circle ABC Ehsan reaches the point A of the circle in 10 minutes.

So angle of centre produced by the arc AB is

$$\angle AOB = 28^\circ$$

$$OB = \text{radius} = \frac{180}{2} \text{ metre} = 90 \text{ metre}$$

Suppose arc $AB = s$ metre

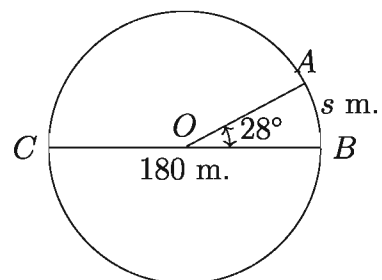

We know,

$$s = r\theta$$

$$= 90 \times 28 \times \frac{\pi}{180} \text{ metre}$$

$$= 14\pi \text{ metre}$$

$$= 14 \times 3.1416 \text{ metre (nearly)}$$

$$= 43.98 \text{ metre (nearly)}$$

\therefore Ehsan's speed = $\frac{43.98}{10}$ metre/second = 4.398 metre/second = 4.4 metre/second (nearly).

Determinable speed: 4.4 metre/second (nearly).

Example 9. A hill subtends an angle of $7'$ at a point 540 kilometre from the foot of the hill. Find the height of the hill.

Solution: Let foot A of the hill AB makes angle $7'$ with the point O 540 km. away from A . So, $AO = r = \text{radius} = 540 \text{ k.m.}$

Circular angle $\angle AOB = 7' = \left(\frac{7}{60}\right)^\circ = \frac{7\pi}{60 \times 180}$ radian.

Height of the hill \approx arc $AB = s \text{ k.m.}$

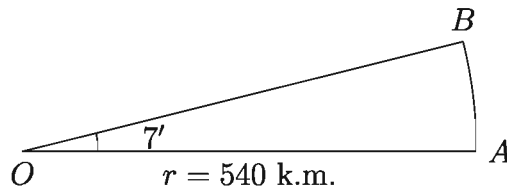

We know,

$$s = r\theta = 540 \times \frac{7\pi}{60 \times 180} \text{ k.m.}$$

$$= \frac{7 \times 3.1416}{20} \text{ k.m. (nearly)}$$

$$= 1.1 \text{ k.m. (nearly)}$$

\therefore Height of the hill is 1.1 k.m. (nearly) or 1100 m. (nearly).

Exercise 8.1

Use calculator to solve the following problems. Use ($\pi = 3.1416$) as the approximate value of π in every case where necessary.

1. 1) Express in radians :

(i) $75^\circ 30'$	(ii) $55^\circ 54' 53''$	(iii) $33^\circ 22' 11''$
--------------------	--------------------------	---------------------------
- 2) Express in degrees :

(i) $\frac{8\pi}{13}$ radian	(ii) 1.3177 radian	(iii) 0.9759 radian
------------------------------	--------------------	---------------------
2. If we express an angle by D° and R^c in radian and circular system then prove that, $\frac{D}{180} = \frac{R}{\pi}$.
3. The radius of a wheel is 2 metre 3 c.m. Find approximate value of its circumference to four places of decimals.
4. The diameter of the wheel of a car is 0.84 metre and the wheel makes 6 revolutions per second. Find the speed of the car.
5. The angle of a triangle are in the ratio 2 : 5 : 3; what are the circular measures of the smallest and the largest angles ?
6. The angles of a triangle are in arithmetical progression and the largest angle is twice the smallest angle. What are the radian measures of the angles ?
7. The arc joining Dhaka with Chittagong subtends an angle of 5° at the centre of the earth. Taking the earth to be a sphere of radius of 6440 k.m. find the distance of Chittagong from Dhaka.
8. The arc joining Teknaf with Tetulia subtends an angle of $10^\circ 6' 3''$ at the centre of the earth. Taking the earth to be a sphere of radius 6440 k.m., find the distance of Tetulia and Teknaf.
9. Riding a bicycle Shahed traverses a segment of a circular path in 11 seconds. The diameter of the circular path is 201 metre and the angle subtended by the segment at the centre is 30° ; find Shahed's speed.
10. Given that the radius of the earth is 6440 k.m, what is the distance between the two places on the surface of the earth which subtend an angle of $32''$ at the centre of the earth?

11. Express in radian the angle between the minute hand and hour hand of a clock when it is 9 : 30 a.m. [Hint. One spacing on the dial subtends $\frac{360^\circ}{60} = 6^\circ$ degree angle at the centre. At 9 : 30 A.M.(or P.M.) the hour and minute hands of the clock are $\left(15 + 2\frac{1}{2}\right)$ or $17\frac{1}{2}$ spacing a part]
12. A person jogging on a circular track at 6 k.m. per hour, traverses a segment of the path in 36 seconds which subtends angle of 60° at the centre. Find the diameter of the circular track.
13. A hill subtends an angle of $8'$ at a point at a distance of 750 kilometre from the foot of the hill. Find the height of the hill.

Trigonometric Ratios (Trigonometric Ratios)

We discuss about trigonometrical ratios (sine, cosine, tangent, secant, cosecant, cotangent) of acute angle in this section. By the ratios of acute angle, we can determine the technique of any trigonometrical angle. Relation among the ratios and its sign in different quadrant can be explained. Some identity about trigonometric ratios are to be conceptualized. Trigonometrical ratios and the maximum or minimum values of trigonometric ratios of standard angle $\left(0, \frac{\pi}{6}, \frac{\pi}{4}, \frac{\pi}{3}, \frac{\pi}{2}\right)$ are also included here.

(a) Trigonometrical Ratios of Acute Angle (Trigonometric Ratios of Acute Angles):

We consider a right angle triangle $\triangle OPQ$ to discuss the trigonometrical ratios of acute angle. In $\triangle OPQ$, $\angle OQP$ is the right angle, OP is the hypotenuse of the triangle, OQ is the adjacent side, PQ is the opposite side and $\angle POQ = \theta$ is an acute angle subjected to $\angle POQ$. In OPQ the trigonometrical ratios of acute angle θ (sine, cosine, tangent, secant, cosecant, cotangent) are defined below:

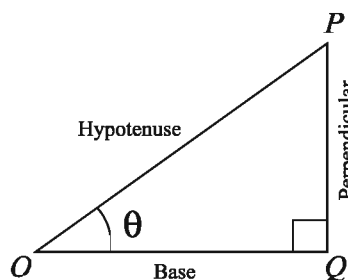

$$\sin\theta = \frac{PQ}{OP} = \frac{\text{Perpendicular}}{\text{Hypotenuse}}$$

$$\operatorname{cosec}\theta = \frac{OP}{PQ} = \frac{\text{Hypotenuse}}{\text{Perpendicular}}$$

$$\cos\theta = \frac{OQ}{OP} = \frac{\text{Base}}{\text{Hypotenuse}}$$

$$\sec\theta = \frac{OP}{OQ} = \frac{\text{Hypotenuse}}{\text{Base}}$$

$$\tan\theta = \frac{PQ}{OQ} = \frac{\text{Perpendicular}}{\text{Base}} \qquad \cot\theta = \frac{OQ}{PQ} = \frac{\text{Base}}{\text{Perpendicular}}$$

Example 10. In a right angle triangle $\tan\theta = 3$ then find the other trigonometrical ratios of θ

Solution: Let ABC is a right angle triangle where, hypotenuse = AC , base = AB , perpendicular = BC and $\angle BAC = \theta$

Here $\tan\theta = 3$

$$\text{or, } \tan\theta = \frac{\text{Perpendicular}}{\text{Base}} = \frac{3}{1}$$

\therefore Perpendicular $BC = 3$ unit and Base $AB = 1$ unit.

By Pythagoras

$$\text{Hypotenuse } AC = \sqrt{AB^2 + BC^2} = \sqrt{1^2 + 3^2} = \sqrt{10} \text{ unit}$$

\therefore other trigonometrical ratios are

$$\sin\theta = \frac{\text{Perpendicular}}{\text{Hypotenuse}} = \frac{3}{\sqrt{10}} \qquad \text{cosec}\theta = \frac{\text{Hypotenuse}}{\text{Perpendicular}} = \frac{\sqrt{10}}{3}$$

$$\cos\theta = \frac{\text{Base}}{\text{Hypotenuse}} = \frac{1}{\sqrt{10}} \qquad \sec\theta = \frac{\text{Hypotenuse}}{\text{Base}} = \frac{\sqrt{10}}{1} = \sqrt{10}$$

$$\text{and } \cot\theta = \frac{\text{Base}}{\text{Perpendicular}} = \frac{1}{3}$$

Observation : The trigonometrical ratios sine, cosine, tangent, secant, cosecant and cotangent have no unit as ratios are unit base.

Activity: ABC is a right angle triangle and $\sin\theta = \frac{2}{\sqrt{5}}$. Find the other trigonometrical ratios of θ .

Note: Trigonometric ratios are written in brief. e.g.

$$\text{sine}\theta = \sin\theta, \quad \text{cosine}\theta = \cos\theta, \quad \text{tangent}\theta = \tan\theta,$$

$$\text{secant}\theta = \sec\theta, \quad \text{cosecant}\theta = \text{cosec}\theta, \quad \text{cotangent}\theta = \cot\theta$$

(b) Trigonometric ratio of any angle: Here we find the trigonometric ratios of any angle. For this we need to know the standard position of the angle. In Cartesian plane right side from origin that is considering the positive direction of

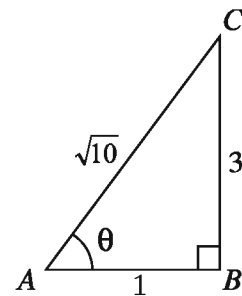

x -axis as initial ray be obtained the position of the angle. Here we consider θ as trigonometric angle and the limit of θ is boundless.

In Cartesian plane suppose $X'OX$ as x -axis, $Y'OY$ as y -axis and O as origin. Angle θ is the product by revolving a ray OA in the anticlock-wise direction from x -axis i.e. OX is the initial side and OA is the terminal side. (Following figure)

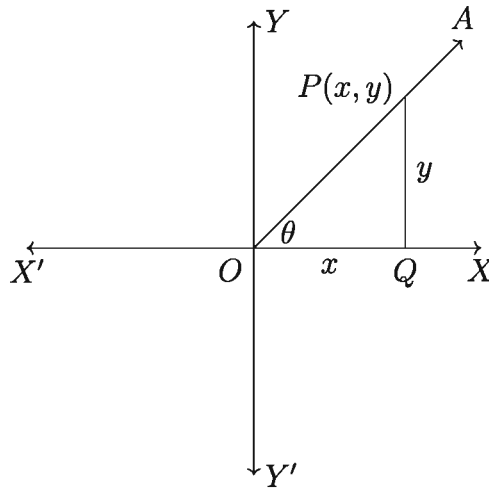

OX is called the initial side of the angle θ and OA is called the terminal side. Take a point $P(x, y)$ different from O on the terminal side OA . So perpendicular distance of the point from OX is y , from OY is x and $\angle OQP$ is a right angle (see the above figure).

Therefore, by Pythagoras, hypotenuse $|OP| = r = \sqrt{x^2 + y^2}$. So for any angle θ the trigonometric ratios will be :

$$\sin\theta = \frac{\text{Perpendicular}}{\text{Hypotenuse}} = \frac{y}{r}$$

$$\cos\theta = \frac{\text{Base}}{\text{Hypotenuse}} = \frac{x}{r}$$

$$\tan\theta = \frac{\text{Perpendicular}}{\text{Base}} = \frac{y}{x} \quad [x \neq 0]$$

$$\sec\theta = \frac{\text{Hypotenuse}}{\text{Base}} = \frac{r}{x} \quad [x \neq 0]$$

$$\operatorname{cosec}\theta = \frac{\text{Hypotenuse}}{\text{Perpendicular}} = \frac{r}{y} \quad [y \neq 0]$$

$$\cot\theta = \frac{\text{Base}}{\text{Perpendicular}} = \frac{x}{y} \quad [y \neq 0]$$

Observation 1. As the point P and O are different so $r = |OP| > 0$ and $\sin\theta$ and $\cos\theta$ significant. The terminal side OA lie in x -axis then $y = 0$ and in that case $\operatorname{cosec}\theta$ and $\cot\theta$ is not defined.

Similarly terminal side OA lie in y -axis then $x = 0$ and in that case $\sec\theta$ and $\tan\theta$ is not defined.

Observation 2. Take another point $P_1(x_1, y_1)$ different from $P(x, y)$ (Following left and right figure) on the terminal side OA . Draw perpendicular PM and P_1M_1 from $P(x, y)$ and $P_1(x_1, y_1)$ on x -axis. So, $\triangle OPM$ and $\triangle OP_1M_1$ are similar.

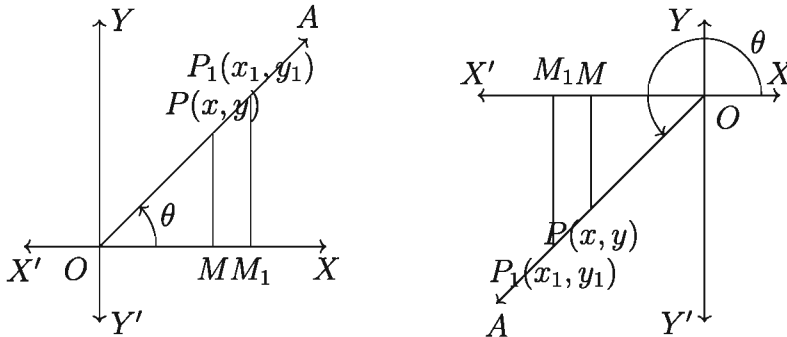

$$\text{i.e., } \frac{|x|}{|x_1|} = \frac{|y|}{|y_1|} = \frac{|OP|}{|OP_1|} = \frac{r}{r_1}$$

Here $OP = r$, $OP_1 = r_1$, x and x_1 and y and y_1 are of the same sign.

$$\therefore \frac{x}{x_1} = \frac{y}{y_1} = \frac{r}{r_1} \quad \text{That is, } \frac{x}{r} = \frac{x_1}{r_1} \quad \text{and} \quad \frac{y}{r} = \frac{y_1}{r_1}$$

$$\text{Therefore, } \sin\theta = \frac{y}{r} = \frac{y_1}{r_1}$$

$$\cos\theta = \frac{x}{r} = \frac{x_1}{r_1} \quad \tan\theta = \frac{y}{x} = \frac{y_1}{x_1} \text{ etc.}$$

Decision : Value of trigonometric ratios are not dependent upon the point P on OA .

Observation 3. If θ is an acute angle, the standard position of OA lies in the first quadrant and $\theta = \angle XOA$ (Figure beside). Take any point $P(x, y)$ on OA and draw perpendicular PM on OX so that we can find the value of ratios θ from the discussion by (a) and (b) $OM = x$, $PM = y$ and $OP = r$.

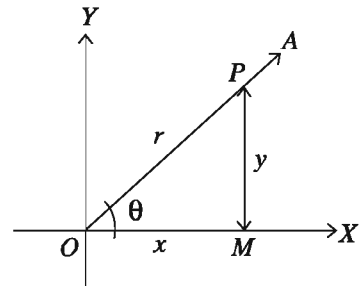

(c) **Relations of the trigonometric ratios:**

From the definitions of

trigonometric ratios we see that,

$$\sin\theta = \frac{\text{Perpendicular}}{\text{Hypotenuse}}, \text{ cosec}\theta = \frac{\text{Hypotenuse}}{\text{Perpendicular}} = \frac{1}{\frac{\text{Perpendicular}}{\text{Hypotenuse}}} = \frac{1}{\sin\theta}$$

$$\therefore \sin\theta = \frac{1}{\text{cosec}\theta} \text{ and } \text{cosec}\theta = \frac{1}{\sin\theta}$$

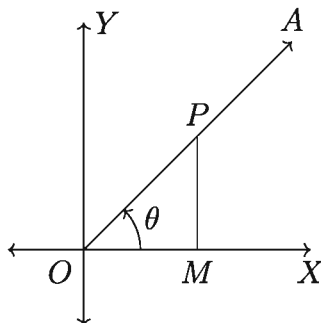

$$\text{Similarly, } \cos\theta = \frac{\text{Base}}{\text{Hypotenuse}}, \text{ sec}\theta = \frac{\text{Hypotenuse}}{\text{Base}} = \frac{1}{\frac{\text{Base}}{\text{Hypotenuse}}} = \frac{1}{\cos\theta}$$

$$\text{i.e. } \cos\theta = \frac{1}{\text{sec}\theta} \text{ and } \text{sec}\theta = \frac{1}{\cos\theta}$$

$$\text{Similarly, } \tan\theta = \frac{1}{\cot\theta} \text{ and } \cot\theta = \frac{1}{\tan\theta}$$

Some easy identities concerning about trigonometrical ratios (Identities):

$$(i) \sin^2\theta + \cos^2\theta = 1$$

Proof: From the figure we see that,

$$\cos\theta = \frac{\text{Base}}{\text{Hypotenuse}} = \frac{x}{r}$$

$$\sin\theta = \frac{\text{Perpendicular}}{\text{Hypotenuse}} = \frac{y}{r}$$

$$\text{and } r^2 = x^2 + y^2$$

$$\therefore \sin^2\theta + \cos^2\theta = \frac{x^2}{r^2} + \frac{y^2}{r^2} = \frac{x^2 + y^2}{r^2} = \frac{r^2}{r^2} = 1$$

$$\therefore \sin^2\theta + \cos^2\theta = 1 \text{ (Proved).}$$

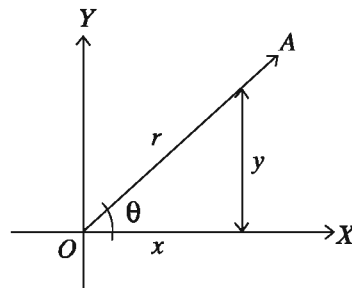

From (i) we have, $\sin^2\theta = 1 - \cos^2\theta$ or, $\cos^2\theta = 1 - \sin^2\theta$

Similarly it can be proved that,

$$(ii) 1 + \tan^2\theta = \sec^2\theta \text{ or, } \sec^2\theta - 1 = \tan^2\theta$$

$$(iii) 1 + \cot^2\theta = \operatorname{cosec}^2\theta \text{ or, } \operatorname{cosec}^2\theta - 1 = \cot^2\theta$$

Activity: Prove that (with the help of figure):

$$1) \sec^2\theta - \tan^2\theta = 1$$

$$2) \operatorname{cosec}^2\theta - \cot^2\theta = 1$$

Sign of trigonometric ratios in different quadrants

In the following figure the Cartesian plane are divided into four quadrant by the axis $X'OX$ and $Y'OY$. Namely XOY (1st quadrant), YOX' (2nd quadrant), $X'OY'$ (3rd quadrant) and $Y'OX$ (4th quadrant) respectively.

The ray OA rotating in the anticlock-wise direction produces different angles depending on the terminal position of OA from the initial position OX . Take any point $P(x, y)$ on the rotating ray OA . So $|OP| = r$. Sign of x and y will be changed depending upon the position of P and the terminal ray OA but r always remains positive.

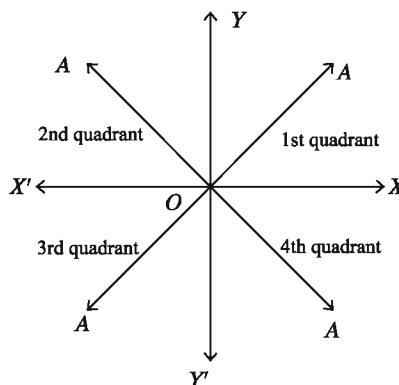

When OA lie in the first quadrant then both x and y are positive. So, all trigonometric ratios in the first quadrant is positive. When OA lie in the second quadrant abscissa x is negative ordinate and y is positive. So in the 2nd quadrant $\sin\left(\sin\theta = \frac{y}{r}\right)$ and $\operatorname{cosec}\left(\operatorname{cosec}\theta = \frac{r}{y}\right)$ are positive and the other ratios are negative. Similarly in the

3rd quadrant abscissa x and y both are negative and $\tan\left(\tan\theta = \frac{-y}{-x} = \frac{y}{x}\right)$ and $\cot\left(\cot\theta = \frac{-x}{-y} = \frac{x}{y}\right)$ are positive and the ratios are negative. When OA lies in the

4th quadrant abscissa x is positive, ordinate y is negative, and so $\cos\left(\cos\theta = \frac{x}{r}\right)$ and $\sec\left(\sec\theta = \frac{r}{x}\right)$ are positive and the other ratios are negative.

Again, in x -axis the value of y is zero, so $\operatorname{cosec}\left(\operatorname{cosec}\theta = \frac{r}{y}\right)$ and $\cot\left(\cot\theta = \frac{x}{y}\right)$ are not defined.

Similarly in y -axis the value of x is zero, so on y -axis $\sec\left(\sec\theta = \frac{r}{x}\right)$ and $\tan\left(\tan\theta = \frac{y}{x}\right)$ is not defined. In any position of the point P the ratios

$\sin\left(\sin\theta = \frac{y}{r}\right)$ and $\cos\left(\cos\theta = \frac{x}{r}\right)$ are defined and has real value.

The precise of the above discussion can be shown below with the help of the figure. With the help of the figure determining all signs of trigonometric ratios of the angle, depending on the terminal ray of the angle, will be easier.

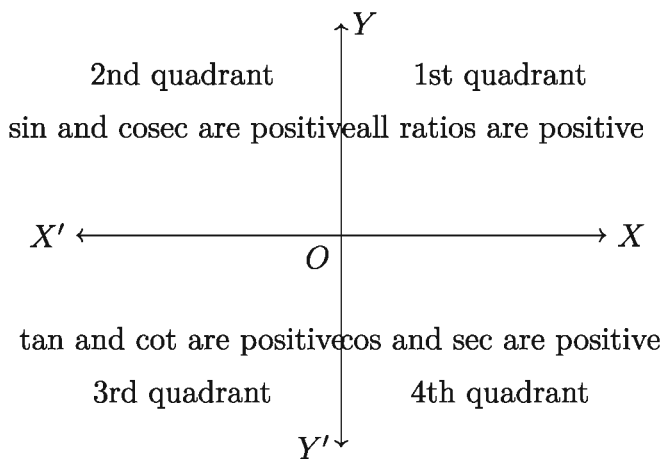

Trigonometric ratios

In class 9 and 10 the trigonometric ratio of acute angle was discussed. Now we shall describe the trigonometric ratio of any angle.

Standard Position of angle: In the main point O of Cartesian plane if an angle is drawn considering x -axis as original ray, standard position of angle can be obtained.

Definition of ratios

Take a point $P(x, y)$ on a rotating ray OZ of standard position of any angle θ where $OP = r(> 0)$. then in angle θ

$$\text{sine ratio, } \sin\theta = \frac{y}{r}$$

$$\text{cosine ratio, } \cos\theta = \frac{x}{r}$$

$$\text{tangent ratio, } \tan\theta = \frac{y}{x} \quad [\text{When } x \neq 0]$$

$$\text{cotangent ratio, } \cot\theta = \frac{x}{y} \quad [\text{When } y \neq 0]$$

$$\text{secant ratio, } \sec\theta = \frac{r}{x} \quad [\text{When } x \neq 0]$$

$$\text{cosecant ratio, } \operatorname{cosec}\theta = \frac{r}{y} \quad [\text{When } y \neq 0]$$

It is to be observed that, $P(x, y)$, $P'(x', y')$ are two points on the ray OZ where $OP = r(> 0)$, $OP' = r'(> 0)$; x , x' and y , y' have same signs.

So from $\triangle OPM$ and $\triangle OP'M'$,

$$\frac{x}{r} = \frac{x'}{r'}, \quad \frac{y}{r} = \frac{y'}{r'} \text{ etc.}$$

So, the value of the ratios of the angle θ do not depend on the position of the point P on the ray OZ .

If θ is an acute angle, then in the right angled triangle $\triangle OPM$ hypotenuse $OP = r$, adjoining side $OM = x$, opposite side $PM = y$. Therefore,

$$\sin\theta = \frac{y}{r} = \frac{\text{opposite side}}{\text{hypotenuse}}$$

$$\cos\theta = \frac{x}{r} = \frac{\text{adjoining side}}{\text{hypotenuse}}$$

$$\tan\theta = \frac{y}{x} = \frac{\text{opposite side}}{\text{adjoining side}}, \text{ etc.}$$

Therefore, in case of acute angle the definition of trigonometric ratio based on coordinate and in class 9 and 10 definition based on right angled triangle are same.

Ratios of the angles 0° and 90° : The rotating ray lies on the segment OX in case of 0° . Therefore, $P(x, 0)$ and $r = OP = x$. So,

$$\sin 0^\circ = \frac{y}{r} = \frac{0}{x} = 0$$

$$\cos 0^\circ = \frac{x}{r} = \frac{x}{x} = 1$$

The rotating ray lies on the segment OY in case of 90° . Therefore, $P(0, y)$ and $r = OP = y$.

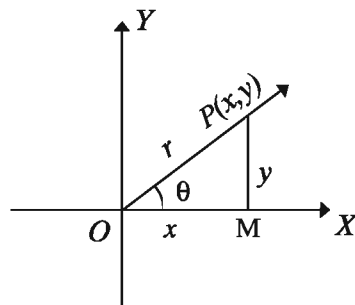
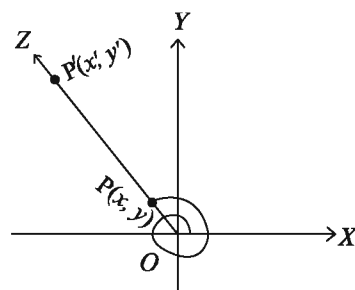
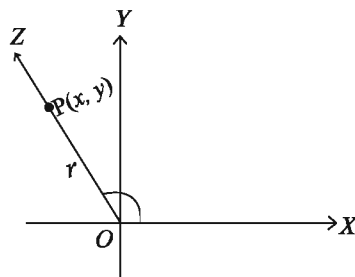

$$\sin 90^\circ = \frac{y}{r} = \frac{y}{y} = 1$$

$$\cos 90^\circ = \frac{x}{r} = \frac{0}{r} = 0$$

From the definition it is seen that, for any angle θ the following rules are applicable for trigonometric ratios.

$$1. \quad \sin^2\theta + \cos^2\theta = 1$$

Proof: $\sin\theta = \frac{y}{r}$, $\cos\theta = \frac{x}{r}$, $r^2 = x^2 + y^2$

$$\therefore \sin^2\theta + \cos^2\theta = \frac{x^2 + y^2}{r^2} = \frac{r^2}{r^2} = 1$$

$$2. \quad \tan\theta = \frac{\sin\theta}{\cos\theta}, \quad \cot\theta = \frac{\cos\theta}{\sin\theta}$$

$$\sec\theta = \frac{1}{\cos\theta}, \quad \operatorname{cosec}\theta = \frac{1}{\sin\theta}$$

where the ratios are defined.

II (-, +)	I(+, +)
III (-, -)	IV (+, -)

3. Considering the signs of different coordinates in the above figure,

II sin, cosec positive	I All ratios positive
III tan, cot positive	IV cos, sec positive

$$4. \quad |\sin\theta| \leq 1, |\cos\theta| \leq 1$$

Proof: $\sin^2\theta + \cos^2\theta = 1$

$$\sin^2\theta \leq 1, \cos^2\theta \leq 1$$

i.e., $|\sin\theta| \leq 1, |\cos\theta| \leq 1$

5. The values of $\sin\theta$, $\cos\theta$ and $\tan\theta$ for different values of θ are following:

	0°	$\frac{\pi}{6} = 30^\circ$	$\frac{\pi}{4} = 45^\circ$	$\frac{\pi}{3} = 60^\circ$	$\frac{\pi}{2} = 90^\circ$
$\sin\theta$	0	$\frac{1}{2}$	$\frac{1}{\sqrt{2}}$	$\frac{\sqrt{3}}{2}$	1
$\cos\theta$	1	$\frac{\sqrt{3}}{2}$	$\frac{1}{\sqrt{2}}$	$\frac{1}{2}$	0
$\tan\theta$	0	$\frac{1}{\sqrt{3}}$	1	$\sqrt{3}$	undefined

Example 11. Find the other trigonometric ratios of acute angle θ ($0 < \theta < \frac{\pi}{2}$) and $\cos\theta = \frac{4}{5}$.

Solution: With the help of trigonometric identities,

We know, $\sin^2\theta + \cos^2\theta = 1$

$$\text{or, } \sin^2\theta = 1 - \cos^2\theta = 1 - \left(\frac{4}{5}\right)^2 = 1 - \frac{16}{25} = \frac{25 - 16}{25} = \frac{9}{25}$$

$$\therefore \sin\theta = \pm\sqrt{\frac{9}{25}} = \pm\frac{3}{5}$$

As θ is an acute angle, so θ is in first quadrant and all its trigonometric ratios are positive.

$$\therefore \sin\theta = \frac{3}{5}$$

$$\text{Now, } \sec\theta = \frac{1}{\cos\theta} = \frac{1}{\frac{4}{5}} = \frac{5}{4}$$

$$\text{cosec}\theta = \frac{1}{\sin\theta} = \frac{1}{\frac{3}{5}} = \frac{5}{3}$$

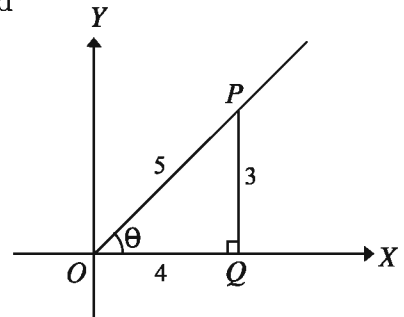

Now from the right angled triangle $\triangle POQ$ we get,

$$\tan\theta = \frac{\text{Perpendicular}}{\text{Base}} = \frac{\text{Perpendicular/Hypotenuse}}{\text{Base/Hypotenuse}} = \frac{PQ/OP}{OQ/OP}$$

$$= \frac{\sin\theta}{\cos\theta} = \frac{3/5}{4/5} = \frac{3}{4}$$

$$\cot\theta = \frac{\text{Base}}{\text{Perpendicular}} = \frac{\text{Base/Hypotenuse}}{\text{Perpendicular/Hypotenuse}} = \frac{OQ/OP}{PQ/OP}$$

$$= \frac{\cos\theta}{\sin\theta} = \frac{4/5}{3/5} = \frac{4}{3}$$

$$\text{N.B. : } \tan\theta = \frac{\sin\theta}{\cos\theta}, \cot\theta = \frac{\cos\theta}{\sin\theta}$$

By trigonometric identities, $\sec^2\theta - \tan^2\theta = 1$

$$\text{or, } \tan^2\theta = \sec^2\theta - 1 = \left(\frac{5}{4}\right)^2 - 1 = \frac{25}{16} - 1 = \frac{9}{16}$$

$$\therefore \tan\theta = \sqrt{\frac{9}{16}} = \frac{3}{4}$$

Again, $\operatorname{cosec}^2\theta - \cot^2\theta = 1$

$$\text{or, } \cot^2\theta = \operatorname{cosec}^2\theta - 1 = \left(\frac{5}{3}\right)^2 - 1 = \frac{25}{9} - 1 = \frac{16}{9}$$

$$\therefore \cot\theta = \sqrt{\frac{16}{9}} = \frac{4}{3}$$

Alternative: We know, $\cos\theta = \frac{\text{Base}}{\text{Hypotenuse}} = \frac{4}{5}$

[Given]

In the figure beside, from the right angled triangle POQ , we get,

$$PQ = \sqrt{OP^2 - OQ^2} = \sqrt{5^2 - 4^2}$$

$$= \sqrt{25 - 16} = \sqrt{9} = 3 \text{ unit}$$

$$\sin\theta = \frac{\text{Perpendicular}}{\text{Hypotenuse}} = \frac{PQ}{OP} = \frac{3}{5}$$

$$\tan\theta = \frac{\text{Perpendicular}}{\text{Base}} = \frac{PQ}{OQ} = \frac{3}{4}$$

$$\sec\theta = \frac{\text{Hypotenuse}}{\text{Base}} = \frac{OP}{OQ} = \frac{5}{4}$$

$$\operatorname{cosec}\theta = \frac{\text{Hypotenuse}}{\text{Perpendicular}} = \frac{OP}{PQ} = \frac{5}{3}$$

$$\cot\theta = \frac{\text{Base}}{\text{Perpendicular}} = \frac{OQ}{PQ} = \frac{4}{3}$$

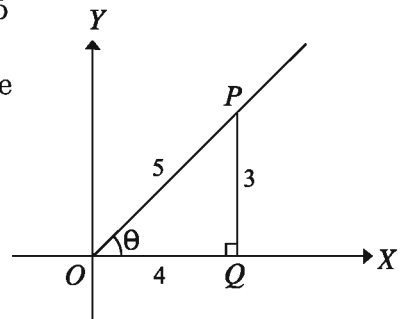

Activity: Find the trigonometric ratios of the obtuse angle θ ($\frac{\pi}{2} < \theta < \pi$) where $\tan\theta = -\frac{1}{2}$ with the help of right angled triangle and trigonometric identities.

Example 12. If $\cos A = \frac{4}{5}$, $\sin B = \frac{12}{13}$ and A and B are both acute angles, the find the values of $\frac{\tan B - \tan A}{1 + \tan B \cdot \tan A}$.

Solution: Given, $\cos A = \frac{4}{5}$

We know, $\sin^2 A + \cos^2 A = 1$

$$\text{or, } \sin^2 A = 1 - \cos^2 A = 1 - \frac{16}{25} = \frac{9}{25}$$

$$\therefore \sin A = \sqrt{\frac{9}{25}} = \frac{3}{5} \text{ [A is an acute angle]}$$

$$\tan A = \frac{\sin A}{\cos A} = \frac{\frac{3}{5}}{\frac{4}{5}} = \frac{3}{4}$$

Again, $\sin B = \frac{12}{13}$

$$\therefore \cos B = \sqrt{1 - \sin^2 B} = \sqrt{1 - \frac{144}{169}} = \sqrt{\frac{25}{169}}$$

$$\therefore \cos B = \frac{5}{13}$$

$$\therefore \tan B = \frac{\sin B}{\cos B} = \frac{12/13}{5/13} = \frac{12}{5}$$

$$\text{Now, } \frac{\tan B - \tan A}{1 + \tan B \cdot \tan A} = \frac{\frac{12}{5} - \frac{3}{4}}{1 + \frac{12}{5} \cdot \frac{3}{4}}$$

$$= \frac{\frac{48 - 15}{20}}{1 + \frac{36}{20}} = \frac{\frac{33}{20}}{\frac{20 + 36}{20}} = \frac{33}{56}$$

$$\therefore \frac{\tan B - \tan A}{1 + \tan B \cdot \tan A} = \frac{33}{56}$$

Example 13. Find the values: $\sin^2 \frac{\pi}{6} + \cos^2 \frac{\pi}{4} + \tan^2 \frac{\pi}{3} + \cot^2 \frac{\pi}{2}$

Solution: We know, $\sin \frac{\pi}{6} = \frac{1}{2}$, $\cos \frac{\pi}{4} = \frac{1}{\sqrt{2}}$, $\tan \frac{\pi}{3} = \sqrt{3}$ and $\cot \frac{\pi}{2} = 0$

$$\therefore \sin^2 \frac{\pi}{6} + \cos^2 \frac{\pi}{4} + \tan^2 \frac{\pi}{3} + \cot^2 \frac{\pi}{2}$$

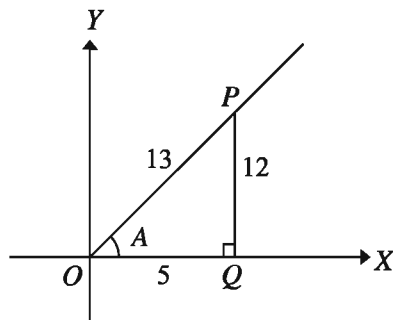
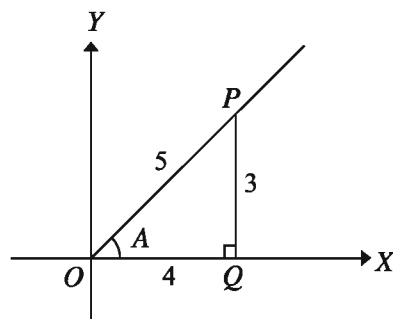

$$\begin{aligned}
 &= \left(\frac{1}{2}\right)^2 + \left(\frac{1}{\sqrt{2}}\right)^2 + (\sqrt{3})^2 + (0)^2 \\
 &= \frac{1}{4} + \frac{1}{2} + 3 = 3\frac{3}{4}
 \end{aligned}$$

Activity:

1) Find the value of $\sin^2\frac{\pi}{4}\cos^2\frac{\pi}{3} + \tan^2\frac{\pi}{6}\sec^2\frac{\pi}{3} + \cot^2\frac{\pi}{3}\operatorname{cosec}^2\frac{\pi}{4}$.

2) Simplify:
$$\frac{\sin^2\frac{\pi}{3} + \sin\frac{\pi}{3}\cos\frac{\pi}{3} + \cos^2\frac{\pi}{3}}{\sin\frac{\pi}{3} + \cos\frac{\pi}{3}} - \frac{\sin^2\frac{\pi}{3} - \sin\frac{\pi}{3}\cos\frac{\pi}{3} + \cos^2\frac{\pi}{3}}{\sin\frac{\pi}{3} - \cos\frac{\pi}{3}}$$

Example 14. If $7\sin^2\theta + 3\cos^2\theta = 4$, prove that, $\tan\theta = \pm\frac{1}{\sqrt{3}}$

Solution: Given, $7\sin^2\theta + 3\cos^2\theta = 4$

or, $7\sin^2\theta + 3(1 - \sin^2\theta) = 4$ [$\because \sin^2\theta + \cos^2\theta = 1$]

or, $7\sin^2\theta + 3 - 3\sin^2\theta = 4 \implies 4\sin^2\theta = 1 \implies \sin^2\theta = \frac{1}{4}$

Again, $\cos^2\theta = 1 - \sin^2\theta = 1 - \frac{1}{4} = \frac{3}{4}$

$$\therefore \tan^2\theta = \frac{\sin^2\theta}{\cos^2\theta} = \frac{\frac{1}{4}}{\frac{3}{4}} = \frac{1}{3}$$

$$\therefore \tan\theta = \pm\frac{1}{\sqrt{3}} \text{ (Proved)}$$

Example 15. If $15\cos^2\theta + 2\sin\theta = 7$ and $-\frac{\pi}{2} < \theta < \frac{\pi}{2}$, Find the value of $\cot\theta$.

Solution: Given, $15\cos^2\theta + 2\sin\theta = 7$

or, $15(1 - \sin^2\theta) + 2\sin\theta = 7$ [$\because \sin^2\theta + \cos^2\theta = 1$]

or, $15 - 15\sin^2\theta + 2\sin\theta = 7 \implies 15\sin^2\theta - 2\sin\theta - 8 = 0$

or, $15\sin^2\theta - 12\sin\theta + 10\sin\theta - 8 = 0 \implies (3\sin\theta + 2)(5\sin\theta - 4) = 0$

$$\therefore \sin\theta = -\frac{2}{3} \text{ or, } \sin\theta = \frac{4}{5}$$

Both value of $\sin\theta$ are acceptable as $-\frac{\pi}{2} < \theta < \frac{\pi}{2}$

$$\text{If } \sin\theta = -\frac{2}{3}, \text{ then } \cos\theta = \sqrt{1 - \sin^2\theta} = \sqrt{1 - \frac{4}{9}} = \frac{\sqrt{5}}{3}$$

$$\text{If } \sin\theta = \frac{4}{5}, \text{ then } \cos\theta = \sqrt{1 - \sin^2\theta} = \sqrt{1 - \frac{16}{25}} = \frac{3}{5}$$

$$\therefore \cot\theta = \frac{\cos\theta}{\sin\theta} = \frac{\frac{\sqrt{5}}{3}}{-\frac{2}{3}} = -\frac{\sqrt{5}}{2} \quad [\text{When } \sin\theta = -\frac{2}{3}]$$

$$\text{Or, } \cot\theta = \frac{\cos\theta}{\sin\theta} = \frac{\frac{3}{5}}{\frac{4}{5}} = \frac{3}{4} \quad [\text{when } \sin\theta = \frac{4}{5}]$$

$$\text{Determinable value } -\frac{\sqrt{5}}{2} \text{ or, } \frac{3}{4}$$

Example 16. If $A = \frac{\pi}{3}$ and $B = \frac{\pi}{6}$, prove that,

$$1) \sin(A + B) = \sin A \cos B + \cos A \sin B$$

$$2) \tan(A - B) = \frac{\tan A - \tan B}{1 + \tan A \tan B}$$

Solution:

$$1) \text{ L.H.S.} = \sin(A + B) = \sin\left(\frac{\pi}{3} + \frac{\pi}{6}\right) = \sin\frac{\pi}{2} = 1$$

$$\text{R.H.S.} = \sin A \cos B + \cos A \sin B = \sin\frac{\pi}{3} \cos\frac{\pi}{6} + \cos\frac{\pi}{3} \sin\frac{\pi}{6}$$

$$= \frac{\sqrt{3}}{2} \cdot \frac{\sqrt{3}}{2} + \frac{1}{2} \cdot \frac{1}{2} = \frac{3}{4} + \frac{1}{4} = 1$$

\therefore L.H.S. = R.H.S. (Proved).

$$2) \text{ L.H.S.} = \tan(A - B) = \tan\left(\frac{\pi}{3} - \frac{\pi}{6}\right) = \tan\frac{\pi}{6} = \frac{1}{\sqrt{3}}$$

$$\text{R.H.S.} = \frac{\tan A - \tan B}{1 + \tan A \tan B} = \frac{\tan\frac{\pi}{3} - \tan\frac{\pi}{6}}{1 + \tan\frac{\pi}{3} \tan\frac{\pi}{6}}$$

$$= \frac{\sqrt{3} - \frac{1}{\sqrt{3}}}{1 + \sqrt{3} \cdot \frac{1}{\sqrt{3}}} = \frac{2}{\sqrt{3}} \times \frac{1}{2} = \frac{1}{\sqrt{3}}$$

\therefore L.H.S. = R.H.S. (Proved).

Activity: If $A = \frac{\pi}{3}$ and $B = \frac{\pi}{6}$ then prove the identification :

$$1) \sin(A - B) = \sin A \cos B - \cos A \sin B$$

$$2) \cos(A + B) = \cos A \cos B - \sin A \sin B$$

$$3) \cos(A - B) = \cos A \cos B + \sin A \sin B$$

$$4) \tan 2B = \frac{2 \tan B}{1 - \tan^2 B}$$

Exercise 8.2

1. Find the value of the followings without using calculator :

$$1) \frac{\cos \frac{\pi}{4}}{\cos \frac{\pi}{6} + \sin \frac{\pi}{3}}$$

$$2) \tan \frac{\pi}{4} + \tan \frac{\pi}{6} \cdot \tan \frac{\pi}{3}$$

2. If $\cos \theta = -\frac{4}{5}$ and $\pi < \theta < \frac{3\pi}{2}$ then, find the value of $\tan \theta$ and $\sin \theta$.

3. If $\sin A = \frac{2}{\sqrt{5}}$ and $\frac{\pi}{2} < A < \pi$ then, what is the value of $\cos A$ and $\tan A$?

4. Given, $\cos A = \frac{1}{2}$ and $\cos A$ and $\sin A$ have the same sign, find the value of $\sin A$ and $\tan A$.

5. Given, $\tan A = -\frac{5}{12}$ and $\tan A$ and $\cos A$ have opposite signs, find the values of $\sin A$ and $\cos A$.

6. Prove the following identities :

$$1) \tan A + \cot A = \sec A \operatorname{cosec} A$$

$$2) \sqrt{\frac{1 + \cos \theta}{1 - \cos \theta}} = \operatorname{cosec} \theta + \cot \theta = \sqrt{\frac{\sec \theta + 1}{\sec \theta - 1}}$$

$$3) \sqrt{\frac{1 - \sin A}{1 + \sin A}} = \sec A - \tan A$$

$$4) \sec^4 \theta - \sec^2 \theta = \tan^4 \theta + \tan^2 \theta$$

$$5) (\sec \theta - \cos \theta)(\operatorname{cosec} \theta - \sin \theta)(\tan \theta + \cot \theta) = 1$$

- 6) $\frac{\tan\theta + \sec\theta - 1}{\tan\theta - \sec\theta + 1} = \tan\theta + \sec\theta$
7. If $\operatorname{cosec}A = \frac{a}{b}$ where $a > b > 0$, then prove that, $\tan A = \frac{\pm b}{\sqrt{a^2 - b^2}}$
8. If $\cos\theta - \sin\theta = \sqrt{2}\sin\theta$, then prove that, $\cos\theta + \sin\theta = \sqrt{2}\cos\theta$
9. If $\tan\theta = \frac{x}{y}$, $x \neq y$, then find the value of $\frac{x\sin\theta + y\cos\theta}{x\sin\theta - y\cos\theta}$.
10. If $\tan\theta + \sec\theta = x$, then show that, $\sin\theta = \frac{x^2 - 1}{x^2 + 1}$
11. If $a\cos\theta - b\sin\theta = c$, then prove that, $a\sin\theta + b\cos\theta = \pm\sqrt{a^2 + b^2 - c^2}$
12. Find the value of :
- 1) $\sin^2\frac{\pi}{6} + \cos^2\frac{\pi}{4} + \tan^2\frac{\pi}{3} + \cot^2\frac{\pi}{6}$
 - 2) $3\tan^2\frac{\pi}{4} - \sin^2\frac{\pi}{3} - \frac{1}{2}\cot^2\frac{\pi}{6} + \frac{1}{3}\sec^2\frac{\pi}{4}$
 - 3) $\tan^2\frac{\pi}{4} - \sin^2\frac{\pi}{3}\tan^2\frac{\pi}{6}\tan^2\frac{\pi}{3}\cos^2\frac{\pi}{4}$
 - 4) $\frac{\tan\frac{\pi}{3} - \tan\frac{\pi}{6}}{1 + \tan\frac{\pi}{3}\tan\frac{\pi}{6}} + \cos\frac{\pi}{3}\cos\frac{\pi}{6} + \sin\frac{\pi}{3}\sin\frac{\pi}{6}$
13. Simplify :
- $$\frac{1 - \sin^2\frac{\pi}{6}}{1 + \sin^2\frac{\pi}{4}} \times \frac{\cos^2\frac{\pi}{3} + \cos^2\frac{\pi}{6}}{\operatorname{cosec}^2\frac{\pi}{2} - \cot^2\frac{\pi}{2}} \div \left(\sin\frac{\pi}{3}\tan\frac{\pi}{6} \right) + \left(\sec^2\frac{\pi}{6} - \tan^2\frac{\pi}{6} \right)$$

Trigonometric ratios of many angles

We discussed the technique about determining the ratios of an acute angle $\left(0 < \theta < \frac{\pi}{2}\right)$ in the second part of trigonometry. Some easy identities are proved concerning relations of ratios. Sign of ratios in different quadrants, trigonometrical ratios of standard angles, idea of maximum and minimum values of ratios are conceptualized. Now we shall determine the ratios of negative angle $(-\theta)$ first. Based on them we will discuss the trigonometrical ratios of the angles $\frac{\pi}{2} - \theta$,

$\frac{\pi}{2} + \theta$, $\pi + \theta$, $\pi - \theta$, $\frac{3\pi}{2} + \theta$, $\frac{3\pi}{2} - \theta$, $2\pi + \theta$, $2\pi - \theta$ and $\frac{n\pi}{2} + \theta$ and $\frac{n\pi}{2} - \theta$ [where n is positive integer and $0 < \theta < \frac{\pi}{2}$]

Trigonometric ratios of $(-\theta)$ where $(0 < \theta < \frac{\pi}{2})$

Suppose the revolving ray OA from its initial position OX produces $\angle XO A = \theta$ in anticlockwise direction in the 1st quadrant and in the same distance produces $\angle XO A' = -\theta$ in clockwise direction (Figure below). Take a point $P(x, y)$ on OA . Draw perpendicular PN on OX from $P(x, y)$. By extending PN it intersects OA' on Q . So QN is the perpendicular on OX . As $P(x, y)$ is in the 1st quadrant then $x > 0$, $y > 0$ and $ON = x$, $PN = y$.

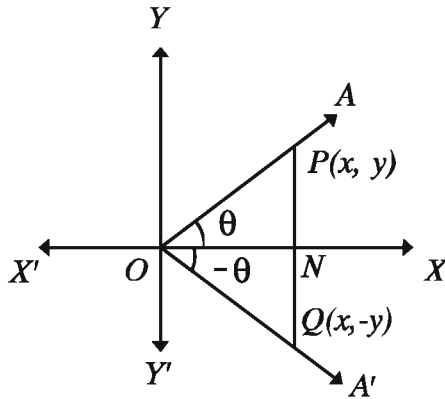

Now form the right angled triangle $\triangle OPN$ and $\triangle OQN$, $\angle PON = \angle QON$, $\angle ONP = \angle ONQ$ and ON is common. So the triangles are equal.

$\therefore PN = QN$ and $OP = OQ$.

As the point Q is in the 4th quadrant, so the ordinate is negative. So the co-ordinates of Q is $Q(x, -y)$. In the right angled triangle OQN , $ON =$ base, $QN =$ perpendicular and $OQ =$ hypotenuse $= r$ (suppose).

So from the previous discussion we get,

$$\sin(-\theta) = \frac{\text{Perpendicular}}{\text{Hypotenuse}} = \frac{QN}{OQ} = \frac{-y}{r} = -\frac{PN}{OP} = -\sin\theta$$

$$\cos(-\theta) = \frac{\text{Base}}{\text{Hypotenuse}} = \frac{ON}{OQ} = \frac{x}{r} = \frac{ON}{OP} = \cos\theta$$

$$\tan(-\theta) = \frac{\text{Perpendicular}}{\text{Base}} = \frac{QN}{ON} = \frac{-y}{x} = -\frac{PN}{ON} = -\tan\theta$$

Similarly, $\operatorname{cosec}(-\theta) = -\operatorname{cosec}\theta$, $\sec(-\theta) = \sec\theta$, $\cot(-\theta) = -\cot\theta$

Remark: Above mentioned relations are applicable for any angle θ .

Example 17.

$$\sin\left(-\frac{\pi}{6}\right) = -\sin\left(\frac{\pi}{6}\right), \quad \cos\left(-\frac{\pi}{4}\right) = \cos\left(\frac{\pi}{4}\right), \quad \tan\left(-\frac{\pi}{4}\right) = -\tan\left(\frac{\pi}{4}\right),$$

$$\operatorname{cosec}\left(-\frac{\pi}{3}\right) = -\operatorname{cosec}\left(\frac{\pi}{3}\right), \quad \sec\left(-\frac{\pi}{3}\right) = \sec\left(\frac{\pi}{3}\right), \quad \cot\left(-\frac{\pi}{6}\right) = -\cot\left(\frac{\pi}{6}\right).$$

Angle or complimentary angle of $\left(\frac{\pi}{2} - \theta\right)$ where $\left(0 < \theta < \frac{\pi}{2}\right)$:

Suppose a revolving ray OA from its initial position OX produces $\angle XOA = \theta$ in the 1st quadrant in anticlock-wise direction. Again another ray OA' from its initial position OX produces $\angle XOY = \frac{\pi}{2}$ in the same direction and then produce $\angle YOA' = -\theta$ in clock-wise direction from the position OY (Figure below).

$$\text{So, } \angle XOA' = \frac{\pi}{2} + (-\theta) = \frac{\pi}{2} - \theta$$

Draw perpendiculars PM and QN from P and Q on OX triangle equal the distance OP and OQ . Now, from right angled triangle $\triangle POM$ and $\triangle QON$, $\angle OMP = \angle ONQ$, $\angle POM = \angle OQN$ and $OP = OQ$.

\therefore The triangles are congruent.

$\therefore ON = PM$ and $QN = OM$

If the co-ordinates of P is (x, y) , then

$$OM = x, \quad PM = y$$

$$\therefore ON = y, \quad QN = x$$

\therefore The co-ordinates of Q is (y, x)

Now, from the triangle $\triangle NOQ$ we get,

$$\sin\left(\frac{\pi}{2} - \theta\right) = \frac{x}{r} = \cos\theta, \quad \cos\left(\frac{\pi}{2} - \theta\right) = \frac{y}{r} = \sin\theta$$

$$\tan\left(\frac{\pi}{2} - \theta\right) = \frac{x}{y} = \cot\theta$$

$$\text{Similarly, } \operatorname{cosec}\left(\frac{\pi}{2} - \theta\right) = \sec\theta, \quad \sec\left(\frac{\pi}{2} - \theta\right) = \operatorname{cosec}\theta$$

$$\cot\left(\frac{\pi}{2} - \theta\right) = \tan\theta$$

Remark: Above mentioned relations are applicable for any angle θ .

Example 18. $\sin\left(\frac{\pi}{3}\right) = \sin\left(\frac{\pi}{2} - \frac{\pi}{6}\right) = \cos\frac{\pi}{6}$

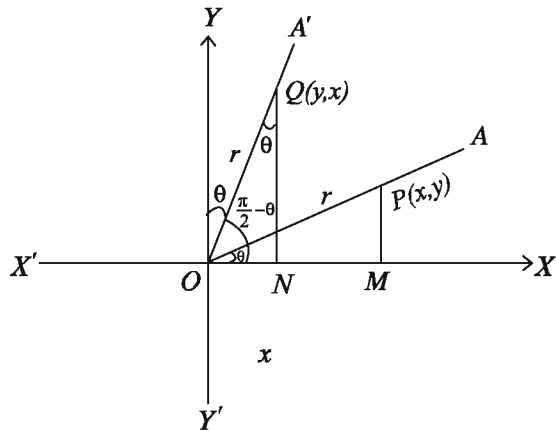

$$\tan\left(\frac{\pi}{6}\right) = \tan\left(\frac{\pi}{2} - \frac{\pi}{3}\right) = \cot\frac{\pi}{3}, \quad \sec\left(\frac{\pi}{4}\right) = \sec\left(\frac{\pi}{2} - \frac{\pi}{4}\right) = \operatorname{cosec}\frac{\pi}{4}$$

Observation : θ and $\left(\frac{\pi}{2} - \theta\right)$ are complement Angle. Complement of sine, tangent and cotangent are cosine, secant and cotangent.

Trigonometric ratios of $\left(\frac{\pi}{2} + \theta\right)$ where $\left(0 < \theta < \frac{\pi}{2}\right)$:

Suppose revolving ray OA from its initial position OX produces $\angle XOA = \theta$ in the 1st quadrant in anticlock-wise direction and then produces $\angle AOA' = \frac{\pi}{2}$ in the same direction (Figure below).

So, $\angle XOA = \angle YOA' = \theta$ and $\angle XOA' = \frac{\pi}{2} + \theta$.

Let any point $P(x, y)$ on OA . Take a point Q on OA' so that $OP = OQ$. Draw perpendicular PM and QN from P and Q on x -axis.

$$\therefore \angle POM = \angle NQO = \angle YOQ = \theta$$

Now from right angled triangle $\triangle POM$ and $\triangle QON$,

$$\angle POM = \angle NQO, \angle PMO = \angle QNO \text{ and } OP = OQ = r$$

$\therefore \triangle POM$ and $\triangle QON$ congruent.

$$\therefore ON = PM, QN = OM$$

Now, if the co-ordinates of P is (x, y) , then $ON = -PM = -y$ and $QN = OM = x$

\therefore Co-ordinate of Q is $Q(-y, x)$

We get,

$$\sin\left(\frac{\pi}{2} + \theta\right) = \frac{x}{r} = \cos\theta, \quad \cos\left(\frac{\pi}{2} + \theta\right) = \frac{-y}{r} = -\frac{y}{r} = -\sin\theta$$

$$\tan\left(\frac{\pi}{2} + \theta\right) = \frac{x}{-y} = -\frac{x}{y} = -\cot\theta$$

$$\text{Similarly, } \operatorname{cosec}\left(\frac{\pi}{2} + \theta\right) = \sec\theta, \quad \sec\left(\frac{\pi}{2} + \theta\right) = -\operatorname{cosec}\theta$$

$$\cot\left(\frac{\pi}{2} + \theta\right) = -\tan\theta$$

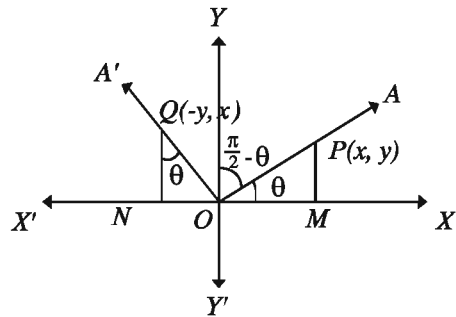

Remark: Above mentioned relations are applicable for any angle θ .

$$\text{Example 19. } \sin\left(\frac{2\pi}{3}\right) = \sin\left(\frac{\pi}{2} + \frac{\pi}{6}\right) = \cos\frac{\pi}{6} = \frac{\sqrt{3}}{2}$$

$$\cos\left(\frac{3\pi}{4}\right) = \cos\left(\frac{\pi}{2} + \frac{\pi}{4}\right) = -\sin\frac{\pi}{4} = -\frac{1}{\sqrt{2}}$$

$$\tan\left(\frac{5\pi}{6}\right) = \tan\left(\frac{\pi}{2} + \frac{\pi}{3}\right) = -\cot\frac{\pi}{3} = -\frac{1}{\sqrt{3}}$$

Activity: Find the value of $\sec\left(\frac{3\pi}{4}\right)$, $\operatorname{cosec}\left(\frac{5\pi}{6}\right)$ and $\cot\left(\frac{2\pi}{3}\right)$.

Trigonometric ratios of $(\pi + \theta)$ where $(0 < \theta < \frac{\pi}{2})$:

Let the revolving ray OA from its initial position OX produces $\angle XOA = \theta$ in the 1st quadrant in anticlock-wise direction and then produces $\angle AOA' = \pi$ revolving in the same direction (Figure below). So, $\angle XOA' = (\pi + \theta)$.

Now take any point P on OA and Q on OA' so that, $OP = OQ = r$. Draw perpendicular PM and QN from P and Q on x -axis.

Now from the right angled triangles $\triangle POM$ and $\triangle QON$, $\angle OMP = \angle ONQ$, $\angle POM = \angle QON$ and $OP = OQ = r$. Therefore, triangles are similar.

$\therefore PM = QN$ and $OM = ON$

Now if the co-ordinate of P is (x, y) , then $ON = -x$, $NQ = -y$

\therefore Co-ordinates of Q is $(-x, -y)$

$$\text{i.e., } \sin(\pi + \theta) = \frac{-y}{r} = -\frac{y}{r} = -\sin\theta$$

$$\cos(\pi + \theta) = \frac{-x}{r} = -\frac{x}{r} = -\cos\theta, \quad \tan(\pi + \theta) = \frac{-y}{-x} = \frac{y}{x} = \tan\theta$$

Similarly, $\operatorname{cosec}(\pi + \theta) = -\operatorname{cosec}\theta$

$\sec(\pi + \theta) = -\sec\theta$, $\cot(\pi + \theta) = \cot\theta$

Remark: Above mentioned relations are applicable for any angle θ .

$$\text{Example 20. } \sin\left(\frac{4\pi}{3}\right) = \sin\left(\pi + \frac{\pi}{3}\right) = -\sin\left(\frac{\pi}{3}\right) = -\frac{\sqrt{3}}{2}$$

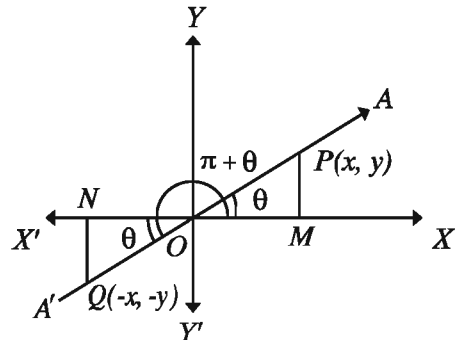

$$\cos\left(\frac{5\pi}{4}\right) = \cos\left(\pi + \frac{\pi}{4}\right) = -\cos\left(\frac{\pi}{4}\right) = -\frac{1}{\sqrt{2}}$$

$$\tan\left(\frac{7\pi}{6}\right) = \tan\left(\pi + \frac{\pi}{6}\right) = \tan\left(\frac{\pi}{6}\right) = \frac{1}{\sqrt{3}}$$

Activity: Find the value of $\sec\left(\frac{4\pi}{3}\right)$, $\operatorname{cosec}\left(\frac{5\pi}{4}\right)$, $\cot\left(\frac{7\pi}{6}\right)$.

Trigonometric ratios of $(\pi - \theta)$ where $(0 < \theta < \frac{\pi}{2})$:

Let the revolving ray OA from the initial line OX produces $\angle XOA = \theta$ in the 1st quadrant in anticlockwise direction and then after producing $\angle XOX' = \pi$ in the same direction, OX' revolves in the clockwise direction to produce $\angle X'OA' = -\theta$ (Figure below). So, $\angle XOA' = \pi + (-\theta) = \pi - \theta$.

Now take a point P on OA and Q on OA' so that, $OP = OQ = r$.

Now in the right angled triangle $\triangle OMP$ and $\triangle ONQ$, $\angle OMP = \angle ONQ$, $\angle POM = \angle QON$ and $OP = OQ = r$. Therefore the triangles are congruent and $ON = OM$, $QN = PM$.

If the co-ordinate of P is (x, y) , then $OM = x$, $PM = y$

$$\therefore ON = -x, NQ = y$$

$$\therefore \text{Co-ordinate of } Q \text{ is } Q(-x, y)$$

$$\text{So, } \sin(\pi - \theta) = \frac{y}{r} = \sin\theta, \quad \cos(\pi - \theta) = \frac{-x}{r} = -\frac{x}{r} = -\cos\theta$$

$$\tan(\pi - \theta) = \frac{y}{-x} = -\frac{y}{x} = -\tan\theta$$

$$\text{Similarly, } \operatorname{cosec}(\pi - \theta) = \operatorname{cosec}\theta$$

$$\sec(\pi - \theta) = -\sec\theta, \quad \cot(\pi - \theta) = -\cot\theta$$

Remark: Above mentioned relations are applicable for any angle θ .

Example 21. $\sin\left(\frac{2\pi}{3}\right) = \sin\left(\pi - \frac{\pi}{3}\right) = \sin\left(\frac{\pi}{3}\right) = \frac{\sqrt{3}}{2}$

$$\cos\left(\frac{3\pi}{4}\right) = \cos\left(\pi - \frac{\pi}{4}\right) = -\cos\left(\frac{\pi}{4}\right) = -\frac{1}{\sqrt{2}}$$

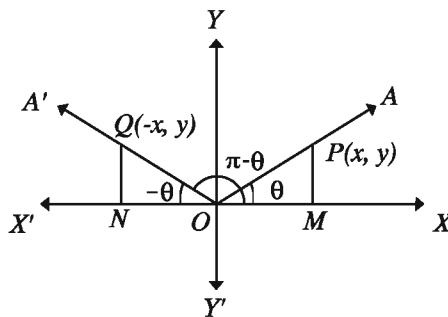

$$\tan\left(\frac{5\pi}{6}\right) = \tan\left(\pi - \frac{\pi}{6}\right) = -\tan\left(\frac{\pi}{6}\right) = -\frac{1}{\sqrt{3}}$$

Activity: Find the value of $\operatorname{cosec}\left(\frac{3\pi}{4}\right)$, $\sec\left(\frac{5\pi}{6}\right)$, $\cot\left(\frac{2\pi}{3}\right)$.

Observation: θ and $(\pi - \theta)$ are supplementary angles. Sine and cosecant is supplementary angles are equal and of same in sign. But cosine, secant, tangent and cotangent are equal and of opposite sign.

Trigonometric ratios of $\left(\frac{3\pi}{2} - \theta\right)$ where $(0 < \theta < \frac{\pi}{2})$:

From preceding discussion we get,

$$\sin\left(\frac{3\pi}{2} - \theta\right) = \sin\left\{\pi + \left(\frac{\pi}{2} - \theta\right)\right\} = -\sin\left(\frac{\pi}{2} - \theta\right) = -\cos\theta$$

$$\cos\left(\frac{3\pi}{2} - \theta\right) = \cos\left\{\pi + \left(\frac{\pi}{2} - \theta\right)\right\} = -\cos\left(\frac{\pi}{2} - \theta\right) = -\sin\theta$$

$$\tan\left(\frac{3\pi}{2} - \theta\right) = \tan\left\{\pi + \left(\frac{\pi}{2} - \theta\right)\right\} = \tan\left(\frac{\pi}{2} - \theta\right) = \cot\theta$$

$$\text{Similarly, } \operatorname{cosec}\left(\frac{3\pi}{2} - \theta\right) = -\sec\theta$$

$$\sec\left(\frac{3\pi}{2} - \theta\right) = -\operatorname{cosec}\theta, \cot\left(\frac{3\pi}{2} - \theta\right) = \tan\theta.$$

Remark: Above mentioned relations are applicable for any angle θ .

Trigonometric ratios of $(2\pi - \theta)$ where $(0 < \theta < \frac{\pi}{2})$

Standard position of $(2\pi - \theta)$ is in 4th quadrant and similar to $(-\theta)$. So trigonometric ratios of $(-\theta)$ and $(2\pi - \theta)$ are equal.

$$\therefore \sin(2\pi - \theta) = \sin(-\theta) = -\sin\theta, \cos(2\pi - \theta) = \cos(-\theta) = \cos\theta$$

$$\tan(2\pi - \theta) = \tan(-\theta) = -\tan\theta, \operatorname{cosec}(2\pi - \theta) = \operatorname{cosec}(-\theta) = -\operatorname{cosec}\theta$$

$$\sec(2\pi - \theta) = \sec(-\theta) = \sec\theta \text{ and } \cot(2\pi - \theta) = \cot(-\theta) = -\cot\theta$$

Remark: Above mentioned relations are applicable for any angle θ .

Trigonometrical ratios of $(2\pi + \theta)$ where $(0 < \theta < \frac{\pi}{2})$:

Standard position of $(2\pi + \theta)$ is in the 1st quadrant and so the trigonometric ratios of θ and $(2\pi + \theta)$ are same and equal.

$$\therefore \sin(2\pi + \theta) = \sin\theta, \cos(2\pi + \theta) = \cos\theta$$

$$\tan(2\pi + \theta) = \tan\theta, \operatorname{cosec}(2\pi + \theta) = \operatorname{cosec}\theta$$

$$\sec(2\pi + \theta) = \sec\theta, \cot(2\pi + \theta) = \cot\theta.$$

Remark: Above mentioned relations are applicable for any angle θ .

Trigonometric ratios of $\left(\frac{3\pi}{2} + \theta\right)$ where $\left(0 < \theta < \frac{\pi}{2}\right)$:

$$\text{For } \left(\frac{3\pi}{2} + \theta\right), \frac{3\pi}{2} + \theta = 2\pi - \left(\frac{\pi}{2} - \theta\right)$$

$$\therefore \sin\left(\frac{3\pi}{2} + \theta\right) = \sin\left\{2\pi - \left(\frac{\pi}{2} - \theta\right)\right\} = -\sin\left(\frac{\pi}{2} - \theta\right) = -\cos\theta$$

$$\cos\left(\frac{3\pi}{2} + \theta\right) = \cos\left(\frac{\pi}{2} - \theta\right) = \sin\theta$$

$$\tan\left(\frac{3\pi}{2} + \theta\right) = -\tan\left(\frac{\pi}{2} - \theta\right) = -\cot\theta$$

$$\text{Similarly, } \operatorname{cosec}\left(\frac{3\pi}{2} + \theta\right) = -\sec\theta$$

$$\sec\left(\frac{3\pi}{2} + \theta\right) = \operatorname{cosec}\theta, \cot\left(\frac{3\pi}{2} + \theta\right) = -\tan\theta$$

Remark: Above mentioned relations are applicable for any angle θ .

Method of determining the trigonometric ratios of $\left(n \times \frac{\pi}{2} \pm \theta\right)$ where $\left(0 < \theta < \frac{\pi}{2}\right)$:

Trigonometric ratios can be determined by the following steps.

Step 1. We are to divide the given angle into two parts whose one part is n multiple of $\frac{\pi}{2}$ or $\frac{\pi}{2}$ and the other part is an acute angle. i.e., we are to express the given angle in the form $\left(n \times \frac{\pi}{2} \pm \theta\right)$.

Step 2. If n is even the ratio remains the same, that is, sine remains sine, cosine remains cosine etc.

If n is odd the ratio will be changed, that is, sine, tangent and sec will be changed into cosine, cotangent and cosecant, cosine, cotangent.

Step 3. After knowing the position in the quadrant of $\left(n \times \frac{\pi}{2} \pm \theta\right)$ we have to put the sign of ratio determined in step 2

Nota Bene: To determine the ratios students are advised to follow the method discussed here.

Example 22. $\sin\left(\frac{9\pi}{2} + \theta\right)$ here $n = 9$ odd number. So the ratio of sin will be changed into cos. Again, $\left(\frac{9\pi}{2} + \theta\right)$ lie in the 10th or 2nd quadrant. So the sign of sin is positive.

$$\therefore \sin\left(\frac{9\pi}{2} + \theta\right) = \cos\theta$$

$\sin\left(\frac{9\pi}{2} - \theta\right)$ here $n = 9$ odd number and $\left(\frac{9\pi}{2} - \theta\right)$ lies in 9th or 1st quadrant, so sign of sin is positive.

$$\therefore \sin\left(\frac{9\pi}{2} - \theta\right) = \cos\theta$$

In the case of $\tan\left(\frac{9\pi}{2} + \theta\right)$, $n = 9$ is odd, tan will be cot and $\left(\frac{9\pi}{2} + \theta\right)$ lies in the 10th or 2nd quadrant, so the sign of tan is negative.

$$\therefore \tan\left(\frac{9\pi}{2} + \theta\right) = -\cot\theta$$

$$\text{Similarly, } \tan\left(\frac{9\pi}{2} - \theta\right) = \cot\theta$$

Activity: Express the angle θ of the ratios $\sin\left(\frac{11\pi}{2} \pm \theta\right)$, $\cos(11\pi \pm \theta)$, $\tan\left(\frac{17\pi}{2} \pm \theta\right)$, $\cot(18\pi \pm \theta)$, $\sec\left(\frac{19\pi}{2} \pm \theta\right)$ and $\operatorname{cosec}(8\pi \pm \theta)$

Example 23. Find the values of

1) $\sin(10\pi + \theta)$

2) $\cos\left(\frac{19\pi}{3}\right)$

3) $\tan\left(\frac{11\pi}{6}\right)$

4) $\cot\left(\theta - \frac{9\pi}{2}\right)$

5) $\sec\left(-\frac{17\pi}{2}\right)$

Solution:

$$1) \sin(10\pi + \theta) = \sin\left(20 \times \frac{\pi}{2} + \theta\right)$$

Here, $n = 20$ and $\sin\left(20 \times \frac{\pi}{2} + \theta\right)$ is in the 21th quadrant or in the first quadrant.

$$\therefore \sin(10\pi + \theta) = \sin\theta$$

$$2) \cos\left(\frac{19\pi}{3}\right) = \cos\left(6\pi + \frac{\pi}{3}\right) = \cos\left(12 \times \frac{\pi}{2} + \frac{\pi}{3}\right)$$

Here, $n = 12$ and $\frac{19\pi}{3}$ is in the first quadrant.

$$\therefore \cos\left(\frac{19\pi}{3}\right) = \cos\frac{\pi}{3} = \frac{1}{2}$$

$$3) \tan\left(\frac{11\pi}{6}\right) = \tan\left(2\pi - \frac{\pi}{6}\right) = \tan\left(4 \times \frac{\pi}{2} - \frac{\pi}{6}\right)$$

Here, $n = 4$ and $\frac{11\pi}{6}$ is in the fourth quadrant.

$$\therefore \tan\left(\frac{11\pi}{6}\right) = -\tan\frac{\pi}{6} = -\frac{1}{\sqrt{3}}$$

$$4) \cot\left(\theta - \frac{9\pi}{2}\right) = \cot\left\{-\left(\frac{9\pi}{2} - \theta\right)\right\} = -\cot\left(9 \times \frac{\pi}{2} - \theta\right)$$

Here, $n = 9$ and $\frac{9\pi}{2} - \theta$ is in the first quadrant.

$$\therefore \cot\left(\theta - \frac{9\pi}{2}\right) = -(\tan\theta) = -\tan\theta$$

$$5) \sec\left(-\frac{17\pi}{2}\right) = \sec\left(\frac{17\pi}{2}\right) \quad [:\sec(-\theta) = \sec\theta]$$

$$= \sec\left(17 \times \frac{\pi}{2} + 0\right)$$

Here, $n = 17$ and $\frac{17\pi}{2}$, on y axis.

$$\therefore \sec\left(-\frac{17\pi}{2}\right) = \operatorname{cosec}0, \text{undefined.}$$

Example 24. Find the value of:

$$\sin\frac{11}{90}\pi + \cos\frac{1}{30}\pi + \sin\frac{101}{90}\pi + \cos\frac{31}{30}\pi + \cos\frac{5}{3}\pi$$

Solution:

$$\begin{aligned}
 & \sin \frac{11}{90} \pi + \cos \frac{1}{30} \pi + \sin \frac{101}{90} \pi + \cos \frac{31}{30} \pi + \cos \frac{5}{3} \pi \\
 &= \sin \frac{22}{180} \pi + \cos \frac{6}{180} \pi + \sin \frac{202}{180} \pi + \cos \frac{186}{180} \pi + \cos \frac{300}{180} \pi \\
 &= \sin \frac{22}{180} \pi + \cos \frac{6}{180} \pi + \sin \left(\pi + \frac{22}{180} \pi \right) + \cos \left(\pi + \frac{6}{180} \pi \right) + \cos \left(2\pi - \frac{60}{180} \pi \right) \\
 &= \sin \frac{22}{180} \pi + \cos \frac{6}{180} \pi - \sin \frac{22}{180} \pi - \cos \frac{6}{180} \pi + \cos \frac{60}{180} \pi \\
 &= \cos \frac{\pi}{3} \\
 &= \frac{1}{2}
 \end{aligned}$$

Activity: Find the value of:

$$\cos^2 \frac{\pi}{15} + \cos^2 \frac{13\pi}{30} + \cos^2 \frac{16\pi}{15} + \cos^2 \frac{47\pi}{30}$$

Example 25. If $\tan \theta = \frac{5}{12}$ and $\cos \theta$ is negative then prove that,

$$\frac{\sin \theta + \cos(-\theta)}{\sec(-\theta) + \tan \theta} = \frac{51}{26}$$

Solution: $\tan \theta = \frac{5}{12}$ and $\cos \theta$ is negative, so angle θ lie in the third quadrant.

$$\text{i.e., } \tan \theta = \frac{5}{12} = \frac{y}{x}$$

$$\therefore x = 12, y = 5$$

$$\therefore r = \sqrt{(12)^2 + (5)^2} = \sqrt{144 + 25} = \sqrt{169} = 13$$

$$\therefore \sin \theta = \frac{-y}{r} = -\frac{5}{13}, \cos \theta = \frac{-x}{r} = -\frac{12}{13} \text{ and } \sec \theta = \frac{1}{\cos \theta} = -\frac{13}{12}$$

$$\therefore \frac{\sin \theta + \cos(-\theta)}{\sec(-\theta) + \tan \theta} = \frac{\sin \theta + \cos \theta}{\sec \theta + \tan \theta} \quad [\because \cos(-\theta) = \cos \theta, \sec(-\theta) = \sec \theta]$$

$$\begin{aligned}
 &= \frac{-\frac{5}{13} - \frac{12}{13}}{-\frac{13}{12} + \frac{12}{12}} = \frac{-\frac{17}{13}}{-\frac{1}{12}} = \frac{17}{13} \times \frac{12}{8} = \frac{51}{26} \quad [\text{Proved}]
 \end{aligned}$$

Example 26. If $\tan \theta = -\sqrt{3}$, $\frac{\pi}{2} < \theta < 2\pi$, find the value of θ .

Solution: $\tan\theta$ is negative, so the angle θ lies in the second and fourth quadrant

$$\text{In the 2nd quadrant, } \tan\theta = -\sqrt{3} = \tan\left(\pi - \frac{\pi}{3}\right) = \tan\frac{2\pi}{3}$$

$$\therefore \theta = \frac{2\pi}{3}$$

It is acceptable because $\frac{\pi}{2} < \theta < 2\pi$

$$\text{Again, in the 4th quadrant, } \tan\theta = -\sqrt{3} = \tan\left(2\pi - \frac{\pi}{3}\right) = \tan\frac{5\pi}{3}$$

$$\therefore \theta = \frac{5\pi}{3}$$

It is also acceptable because $\frac{\pi}{2} < \theta < 2\pi$

$$\therefore \text{the value of } \theta \text{ is } \frac{2\pi}{3} \text{ and } \frac{5\pi}{3}$$

Example 27. Solve $0 < \theta < \frac{\pi}{2} : \sin\theta + \cos\theta = \sqrt{2}$

$$\text{Solution: } \sin\theta + \cos\theta = \sqrt{2}$$

$$\text{or, } \sin\theta = \sqrt{2} - \cos\theta \implies \sin^2\theta = 2 - 2\sqrt{2}\cos\theta + \cos^2\theta$$

$$\text{or, } 1 - \cos^2\theta = 2 - 2\sqrt{2}\cos\theta + \cos^2\theta$$

$$\text{or, } 2\cos^2\theta - 2\sqrt{2}\cos\theta + 1 = 0 \implies (\sqrt{2}\cos\theta - 1)^2 = 0$$

$$\text{or, } \sqrt{2}\cos\theta - 1 = 0$$

$$\text{or, } \cos\theta = \frac{1}{\sqrt{2}} = \cos\frac{\pi}{4}$$

$$\therefore \theta = \frac{\pi}{4}$$

The required solution is $\theta = \frac{\pi}{4}$

Example 28. $0 < \theta < 2\pi$ then find the solution of the following equation:
 $\sin^2\theta - \cos^2\theta = \cos\theta$

$$\text{Solution: } \sin^2\theta - \cos^2\theta = \cos\theta$$

$$\text{or, } 1 - \cos^2\theta - \cos^2\theta = \cos\theta$$

$$\text{or, } 1 - 2\cos^2\theta - \cos\theta = 0 \implies 2\cos^2\theta + \cos\theta - 1 = 0$$

$$\text{or, } (2\cos\theta - 1)(\cos\theta + 1) = 0$$

$$\therefore 2\cos\theta - 1 = 0 \text{ or } \cos\theta + 1 = 0$$

$$\text{i.e., } \cos\theta = \frac{1}{2} \text{ or } \cos\theta = -1$$

$$\text{i.e., } \cos\theta = \cos\frac{\pi}{3} \text{ or } \cos\theta = \cos\pi$$

$$\therefore \theta = \frac{\pi}{3}, \pi, \frac{5\pi}{3}$$

$$\text{The required solution : } \theta = \frac{\pi}{3}, \pi, \frac{5\pi}{3}$$

Activity: $2(\sin\theta\cos\theta + \sqrt{3}) = \sqrt{3}\cos\theta + 4\sin\theta$ then find the solution of the equation, where $0 < \theta < 2\pi$

Example 29. $A = \frac{\cot\theta + \operatorname{cosec}\theta - 1}{\cot\theta - \operatorname{cosec}\theta + 1}$ and $B = \cot\theta + \operatorname{cosec}\theta$

1) If $\theta = \frac{\pi}{3}$, show that, $B = \sqrt{3}$

2) Prove that, $A^2 - B^2 = 0$

3) If $B = \frac{1}{\sqrt{3}}$ and $0 < \theta \leq 2\pi$, find the approximate value of θ .

Solution:

1) $B = \cot\theta + \operatorname{cosec}\theta = \cot\frac{\pi}{3} + \operatorname{cosec}\frac{\pi}{3} \quad [\because \theta = \frac{\pi}{3}]$

$$= \frac{1}{\sqrt{3}} + \frac{2}{\sqrt{3}} = \frac{3}{\sqrt{3}} = \sqrt{3}$$

2) $A = \frac{\cot\theta + \operatorname{cosec}\theta - 1}{\cot\theta - \operatorname{cosec}\theta + 1}$

$$= \frac{\cot\theta + \operatorname{cosec}\theta - (\operatorname{cosec}^2\theta - \cot^2\theta)}{\cot\theta - \operatorname{cosec}\theta + 1} \quad [\because \operatorname{cosec}^2\theta - \cot^2\theta = 1]$$

$$= \frac{\cot\theta + \operatorname{cosec}\theta - (\operatorname{cosec}\theta + \cot\theta)(\operatorname{cosec}\theta - \cot\theta)}{\cot\theta - \operatorname{cosec}\theta + 1}$$

$$= \frac{(\cot\theta + \operatorname{cosec}\theta)(1 - \operatorname{cosec}\theta + \cot\theta)}{\cot\theta - \operatorname{cosec}\theta + 1} = \cot\theta + \operatorname{cosec}\theta = B$$

$$\therefore A^2 = B^2$$

$$\therefore A^2 - B^2 = 0$$

$$3) B = \frac{1}{\sqrt{3}}$$

$$\text{or, } \cot\theta + \operatorname{cosec}\theta = \frac{1}{\sqrt{3}} \implies \frac{\cos\theta}{\sin\theta} + \frac{1}{\sin\theta} = \frac{1}{\sqrt{3}}$$

$$\text{or, } \frac{\cos\theta + 1}{\sin\theta} = \frac{1}{\sqrt{3}} \implies \sqrt{3}(\cos\theta + 1) = \sin\theta$$

$$\text{or, } 3(\cos^2\theta + 2\cos\theta + 1) = \sin^2\theta \text{ [by square]}$$

$$\text{or, } 3\cos^2\theta + 6\cos\theta + 3 = 1 - \cos^2\theta$$

$$\text{or, } 4\cos^2\theta + 6\cos\theta + 2 = 0 \implies 2\cos^2\theta + 3\cos\theta + 1 = 0$$

$$\text{or, } 2\cos^2\theta + 2\cos\theta + \cos\theta + 1 = 0$$

$$\text{or, } 2\cos\theta(\cos\theta + 1) + 1(\cos\theta + 1) = 0 \implies (\cos\theta + 1)(2\cos\theta + 1) = 0$$

$$\therefore \cos\theta + 1 = 0 \text{ or, } 2\cos\theta + 1 = 0$$

$$\text{i.e., } \cos\theta = -1 \text{ or, } \cos\theta = -\frac{1}{2}$$

$$\text{i.e., } \cos\theta = \cos\pi \text{ or, } \cos\theta = \cos\left(\pi - \frac{\pi}{3}\right), \cos\left(\pi + \frac{\pi}{3}\right)$$

$$\text{i.e., } \theta = \pi \text{ or, } \theta = \frac{2\pi}{3}, \frac{4\pi}{3}. \text{ But } \cot\theta + \operatorname{cosec}\theta = \frac{1}{\sqrt{3}} \text{ is not satisfied by } \theta = \pi, \frac{4\pi}{3}$$

$$\therefore \theta = \frac{2\pi}{3}$$

$$\text{The required solution: } \theta = \frac{2\pi}{3}$$

Exercise 8.3

- If $\sin A = \frac{1}{\sqrt{2}}$, then find the value of $\sin 2A$.
 1) $\frac{1}{\sqrt{2}}$ 2) $\frac{1}{2}$ 3) 1 4) $\sqrt{2}$
- In which quadrant the angle -300° lies?
 1) First 2) Second 3) Third 4) Fourth
- If $\sin\theta + \cos\theta = 1$, then the value of θ is
 (i) 0° (ii) 30° (iii) 90°

Which one of the followings is correct?

- 1) i 2) ii 3) i and ii 4) i and iii

4.

From the figure –

(i) $\tan\theta = \frac{4}{3}$

(ii) $\sin\theta = \frac{5}{3}$

(iii) $\cos^2\theta = \frac{9}{25}$

Which one of the following is correct?

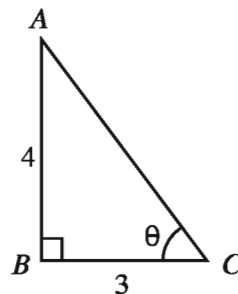

- 1) i and ii 2) i and iii 3) ii and iii 4) i , ii and iii

Answer no. 5 and 6 in accordance with the following figure:

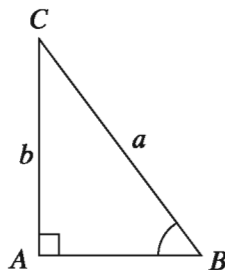
5. $\sin B + \cos C = ?$

- 1) $\frac{2b}{a}$ 2) $\frac{2a}{b}$ 3) $\frac{a^2 + b^2}{ab}$ 4) $\frac{ab}{a^2 + b^2}$

6. What is the value of $\tan B$?

- 1) $\frac{a}{a^2 - b^2}$ 2) $\frac{b}{a^2 - b^2}$
 3) $\frac{a}{\sqrt{a^2 - b^2}}$ 4) $\frac{b}{\sqrt{a^2 - b^2}}$

7. Find the value of

- 1) $\sin 7\pi$ 2) $\cos \frac{11\pi}{2}$ 3) $\cot 11\pi$
 4) $\tan \left(-\frac{23\pi}{6} \right)$ 5) $\operatorname{cosec} \frac{19\pi}{3}$ 6) $\sec \left(-\frac{25\pi}{2} \right)$
 7) $\sin \frac{31\pi}{6}$ 8) $\cos \left(-\frac{25\pi}{6} \right)$

8. Prove that,

1) $\cos \frac{17\pi}{10} + \cos \frac{13\pi}{10} + \cos \frac{9\pi}{10} + \cos \frac{\pi}{10} = 0$

2) $\tan \frac{\pi}{12} \tan \frac{5\pi}{12} \tan \frac{7\pi}{12} \tan \frac{11\pi}{12} = 1$

$$3) \sin^2 \frac{\pi}{7} + \sin^2 \frac{5\pi}{14} + \sin^2 \frac{8\pi}{7} + \sin^2 \frac{9\pi}{14} = 2$$

$$4) \sin \frac{7\pi}{3} \cos \frac{13\pi}{6} - \cos \frac{5\pi}{3} \sin \frac{11\pi}{6} = 1$$

$$5) \sin \frac{13\pi}{3} \cos \frac{13\pi}{6} - \sin \frac{11\pi}{6} \cos \left(-\frac{5\pi}{3} \right) = 1$$

$$6) \text{ If } \tan \theta = \frac{3}{4} \text{ and } \sin \theta \text{ are negative, show that } \frac{\sin \theta + \cos \theta}{\sec \theta + \tan \theta} = \frac{14}{5}$$

9. Find the value of

$$1) \cos \frac{9\pi}{4} + \cos \frac{5\pi}{4} + \sin \frac{31\pi}{36} - \sin \frac{5\pi}{36}$$

$$2) \cot \frac{\pi}{20} \cot \frac{3\pi}{20} \cot \frac{5\pi}{20} \cot \frac{7\pi}{20} \cot \frac{9\pi}{20}$$

$$3) \sin^2 \frac{\pi}{4} + \sin^2 \frac{3\pi}{4} + \sin^2 \frac{5\pi}{4} + \sin^2 \frac{7\pi}{4}$$

$$4) \cos^2 \frac{\pi}{8} + \cos^2 \frac{3\pi}{8} + \cos^2 \frac{5\pi}{8} + \cos^2 \frac{7\pi}{8}$$

$$5) \sin^2 \frac{17\pi}{18} + \sin^2 \frac{5\pi}{8} + \cos^2 \frac{37\pi}{18} + \cos^2 \frac{3\pi}{8}$$

10. If $\theta = \frac{\pi}{3}$ then prove the following identities :

$$1) \sin 2\theta = 2\sin \theta \cos \theta = \frac{2\tan \theta}{1 + \tan^2 \theta} \quad 2) \sin 3\theta = 3\sin \theta - 4\sin^3 \theta$$

$$3) \cos 3\theta = 4\cos^3 \theta - 3\cos \theta \quad 4) \tan 2\theta = \frac{2\tan \theta}{1 - \tan^2 \theta}$$

11. Find the value of α satisfying the given conditions :

$$1) \cot \alpha = -\sqrt{3}, \frac{3\pi}{2} < \alpha < 2\pi \quad 2) \cos \alpha = -\frac{1}{2}, \frac{\pi}{2} < \alpha < \frac{3\pi}{2}$$

$$3) \sin \alpha = -\frac{\sqrt{3}}{2}, \frac{\pi}{2} < \alpha < \frac{3\pi}{2} \quad 4) \cot \alpha = -1, \pi < \alpha < 2\pi$$

12. Solve : (where $0 < \theta < \frac{\pi}{2}$)

$$1) 2\cos^2 \theta = 1 + 2\sin^2 \theta \quad 2) 2\sin^2 \theta - 3\cos \theta = \frac{7}{4}$$

$$3) 6\sin^2 \theta - 11\sin \theta + 4 = 0 \quad 4) \tan \theta + \cot \theta = \frac{1}{\sqrt{3}}$$

$$5) 2\sin^2 \theta + 3\cos \theta = 3$$

13. Solve : (where $0 < \theta < 2\pi$)

$$1) 2\sin^2 \theta + 3\cos \theta = 0 \quad 2) 4(\cos^2 \theta + \sin \theta) = 5$$

$$3) \cot^2 \theta + \operatorname{cosec}^2 \theta = 3 \quad 4) \tan^2 \theta + \cot^2 \theta = 2$$

5) $\sec^2\theta + \tan^2\theta = \frac{5}{3}$

6) $5\operatorname{cosec}^2\theta - 7\cot\theta\operatorname{cosec}\theta - 2 = 0$

7) $2\sin x \cos x = \sin x \quad (0 \leq x \leq 2\pi)$

14. Radius of the Earth is 6440 km. Dhaka and Panchagar make 3.5° angle at the centre of the Earth. A person wants to enjoy scenic natural beauty of Panchagar in the winter. He reached Panchagar with a vehicle having a wheel of diameter 0.84 m.

- 1) What is the angle in radians Dhaka and Panchagar make at the centre of the Earth?
- 2) What is the distance between Dhaka and Panchagar?
- 3) How many revolutions will the wheel make while travelling to Panchagar from Dhaka?

15.

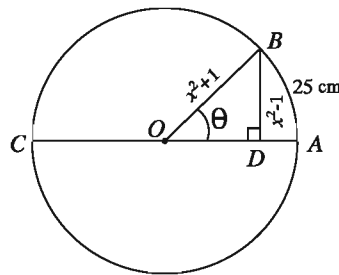

- 1) In figure ABC is a circular wheel and length of the arc AB is 25 c.m. Find the value of θ . What distance will the wheel cover in a single rotation?
 - 2) What is the speed of the wheel ABC if it revolves 5 times in a second.
 - 3) In the figure find the value of $\sin\theta$ from $\triangle BOD$, to prove that, $\tan\theta + \sec\theta = x$
16. In a right angled triangle if the length of smallest side is 7c.m. and the smallest angle is 15° , then what is the length of hypotenuse?

Chapter 9

Exponential and Logarithmic Function

Exponential and logarithmic functions retain their place and importance in the theory and applications of mathematics as well as real life applications. For example: population growth, compound interest calculation etc.

After completing the chapter, the student will be able to –

- ▶ explain rational and irrational exponents;
- ▶ prove and apply the laws concerning rational and irrational exponents;
- ▶ explain the relation between exponents and logarithms;
- ▶ explain, prove and apply the laws of logarithms;
- ▶ explain the concept of exponential, logarithmic and absolute value functions and solve mathematical problem;
- ▶ sketch the graph of functions;
- ▶ represent exponential, logarithmic and absolute value Function by graphs;
- ▶ find logarithms and antilogarithms using calculators.

Rational and Irrational Exponents

We recall some notations : R denotes the set of real numbers

N denotes the set of natural numbers

Z denotes the set of integers

Q denotes the set of rational numbers

If a is any real number and n is any natural number, when a is multiplied n times, the product is written as $a^n = a \cdot a \cdot a \cdots$ (n times) and a^n is called n th power of a . In such cases, a is called the base and n is called the exponent or index.

\therefore in 3^4 the base is 3 and exponent is 4.

Again, in $\left(\frac{2}{3}\right)^4$, the base is $\frac{2}{3}$ and exponent is 4.

Definition: For all $a \in R$

1. $a^1 = a$
2. $a^n = a \cdot a \cdot a \cdots a$ (n times factor of a), where $n \in N, n > 1$

Irrational Exponent

When an exponent x is irrational, we fix the value of a^x ($a > 0$) so that for some rational value p approximate to x , the value of a^p is close to the value of a^x . For example, we consider the number $3^{\sqrt{5}}$. We know, $\sqrt{5}$ is an irrational number and $\sqrt{5} = 2.236067977 \cdots$ (We have obtained this value using calculator and \cdots indicates that the decimal expression is infinite).

As the approximate values of $\sqrt{5}$ considering

$$\begin{array}{cccccc} p_1 = 2.23 & p_2 = 2.236 & p_3 = 2.2360 & p_4 = 2.23606 & p_5 = 2.236067 \\ p_6 = 2.2360679 & p_7 = 2.23606797 & & & \end{array}$$

we obtain the following approximate values of $3^{\sqrt{5}}$.

$$\begin{array}{l} q_1 = 3^{2.23} = 11.5872505 \quad q_2 = 3^{2.236} = 11.6638822 \quad q_3 = 3^{2.2360} = 11.6638822 \\ q_4 = 3^{2.23606} = 11.66465109 \quad q_5 = 3^{2.236067} = 11.6647407 \\ q_6 = 3^{2.2360679} = 11.6647523 \quad q_7 = 3^{2.23606797} = 11.6647532 \end{array}$$

This values have also been obtained using calculator.

Actually, $3^{\sqrt{5}} = 11.6647533 \cdots$

Laws of Exponents

Formula 1. If $a \in R$ and $n \in N$, $a^1 = a$, $a^{n+1} = a^n \cdot a$.

Proof: By definition $a^1 = a$ and for all $n \in N$: $a^{n+1} = \underbrace{a \cdot a \cdot a \cdots a \cdot a}_{n \text{ times}} = a^n \cdot a$

Note: N is the set of all natural numbers.

Formula 2. For every $a \in R$ and $m, n \in N$, $a^m \cdot a^n = a^{m+n}$

Proof:

Let us consider the statement $a^m \cdot a^n = a^{m+n} \dots (1)$ fixing some value for $m \in N$ and taking n as the variable.

Putting $n = 1$ in (1) we get,

$$\text{L.H.S} = a^m \cdot a^1 = a^m \cdot a = a^{m+1} = \text{R.H.S} \text{ [Formula 1]}$$

\therefore (1) is true for $n = 1$.

Now, let (1) is true for $n = k$. i.e. $a^m \cdot a^k = a^{m+k}$

Then, $a^m \cdot a^{k+1} = a^m(a^k \cdot a)$ [Formula 1]

$$= (a^m \cdot a^k) \cdot a$$

$$= a^{m+k} \cdot a$$

$$= a^{m+k+1} \text{ [Formula 1]}$$

i.e. (1) is true for $n = k + 1$.

Hence, by mathematical induction for all $n \in N$ (1) is true.

\therefore for every $m, n \in N$ $a^m \cdot a^n = a^{m+n}$

$$\boxed{a^m \cdot a^n = a^{m+n}}$$

This is the functional law of exponents.

□

Formula 3. For every $a \in R, a \neq 0$ and $m, n \in N, m \neq n$,

$$\frac{a^m}{a^n} = \begin{cases} a^{m-n}, & \text{when } m > n \\ \frac{1}{a^{n-m}}, & \text{when } m < n \end{cases}$$

Proof:

1. Suppose, $m > n$. Then $m - n \in N$.

$$\therefore a^{m-n} \cdot a^n = a^{(m-n)+n} = a^m \text{ [Formula 2]}$$

$$\therefore \frac{a^m}{a^n} = a^{m-n} \text{ [definition of division]}$$

2. Suppose, $m < n$. Then $n - m \in N$

$$\therefore a^{n-m} \cdot a^m = a^{(n-m)+m} = a^n \text{ [Formula 2]}$$

$$\therefore \frac{a^m}{a^n} = \frac{1}{a^{n-m}} \text{ [definition of division]}$$

Note: Prove the above formula by mathematical induction. [like formula 2]

Formula 4. If $a \in R$ and $m, n \in N$, then $(a^m)^n = a^{mn}$

Formula 5. For all $a, b \in R$ and $n \in N$, $(a \cdot b)^n = a^n \cdot b^n$

[Prove the above formulae by mathematical induction]

Zero and negative integer exponents:

Definition: For some $a \in R$, if $a \neq 0$,

$$3. a^0 = 1$$

$$4. a^{-n} = \frac{1}{a^n}, \text{ where } n \in N$$

Remark: While expanding the concept of exponent, the validity of the functional law of exponents $a^m \cdot a^n = a^{m+n}$ is assured carefully.

If the formula is true for $m = 0$, then $a^0 \cdot a^n = a^{0+n}$ i.e, $a^0 = \frac{a^n}{a^n} = 1$ must be held.

if the formula is true for $m = 0$, then $a^0 \cdot a^n = a^{0+n}$ i.e, $a^0 = \frac{a^n}{a^n} = 1$ must be held.

Similarly, if the formula needs to be true for $m = -n$ ($n \in N$), then

$a^{-n} \cdot a^n = a^{-n+n} = a^0 = 1$ i.e, $a^{-n} = \frac{1}{a^n}$ must be held. Above definitions have been defined considering these cases.

Example 1. 1) $2^5 \cdot 2^6 = 2^{5+6} = 2^{11}$

$$2) \frac{3^5}{3^3} = 3^{5-3} = 3^2$$

$$3) \frac{3^3}{3^5} = \frac{1}{3^{5-3}} = \frac{1}{3^2}$$

$$4) \left(\frac{5}{4}\right)^3 = \frac{5}{4} \times \frac{5}{4} \times \frac{5}{4} = \frac{5 \times 5 \times 5}{4 \times 4 \times 4} = \frac{5^3}{4^3}$$

$$5) (4^2)^7 = 4^{2 \times 7} = 4^{14}$$

$$6) (a^2 b^3)^5 = (a^2)^5 \cdot (b^3)^5 = a^{2 \times 5} \cdot b^{3 \times 5} = a^{10} b^{15}$$

Example 2. 1) $6^0 = 1$

2) $(-6)^0 = 1$

3) $7^{-1} = \frac{1}{7}$

4) $7^{-2} = \frac{1}{7^2} = \frac{1}{49}$

5) $10^{-1} = \frac{1}{10} = 0.1$

6) $10^{-2} = \frac{1}{10^2} = \frac{1}{100}$

Example 3. If $m, n \in N$, assuming the validity of the law $(a^m)^n = a^{mn}$ show that, $(a^m)^n = a^{mn}$ where $a \neq 0$ and $m \in N$ and $n \in Z$

Solution: Prove that, $(a^m)^n = a^{mn} \dots (1)$

where, $a \neq 0$ and $m \in N$ and $n \in Z$

Step 1. First assume that, $n > 0$, in this case the validity of (1) has been ascertained.

Step 2. Now let, $n = 0$ so here $(a^m)^n = (a^m)^0 = 1$

and, $a^{mn} = a^0 = 1 [\because n = 0]$

\therefore (1) is true.

Step 3. Last suppose, $n < 0$ and $n = -k$, where $k \in N$

Here $(a^m)^n = (a^m)^{-k} = \frac{1}{(a^m)^k} = a^{-mk} = a^{m(-k)} = a^{mn}$

Example 4. Show that, for all $m, n \in N$, $\frac{a^m}{a^n} = a^{m-n}$, where $a \neq 0$

Solution: If $m > n$, $\frac{a^m}{a^n} = a^{m-n}$ [Formula 3]

If $m < n$, $\frac{a^m}{a^n} = \frac{1}{a^{n-m}}$ [Formula 3]

$\therefore \frac{a^m}{a^n} = a^{-(n-m)}$ [Definition 4]

$= a^{m-n}$

If $m = n$, $\frac{a^m}{a^n} = \frac{a^n}{a^n} = 1 = a^0$ [Definition 3]

$= a^{m-m} = a^{m-n}$

Note: From the definitions of exponents described above, for any $m \in Z$ we can get the explanation of a^m , where $a \neq 0$. Considering exponents as positive or zero or negative, we can prove the formula below for all integer exponents.

Formula 6. If $a \neq 0$, $b \neq 0$ and $m, n \in Z$,

$$1. \quad a^m \cdot a^n = a^{m+n}$$

$$2. \quad \frac{a^m}{a^n} = a^{m-n}$$

$$3. \quad (a^m)^n = a^{mn}$$

$$4. \quad (ab)^n = a^n b^n$$

$$5. \quad \left(\frac{a}{b}\right)^n = \frac{a^n}{b^n}$$

Activity:

- 1) Use mathematical induction method to show that, $(a^m)^n = a^{mn}$, where $a \in R$ and $n \in N$
- 2) Use mathematical induction method to show that, $(a \cdot b)^n = a^n \cdot b^n$, where $a, b \in R$ and $n \in N$
- 3) Use mathematical induction to show that, $\left(\frac{1}{a}\right)^n = \frac{1}{a^n}$ where, $a > 0$ and $n \in N$

Next using the formula $(ab)^n = a^n b^n$, show that, $\left(\frac{a}{b}\right)^n = \frac{a^n}{b^n}$, where $a, b \in R, b > 0$ and $n \in N$

- 4) $a \neq 0$ and for positive integer exponent $m, n \in Z$, justify the formula $a^m \cdot a^n = a^{m+n}$ and show that, $a^m \cdot a^n = a^{m+n}$ when (1) $m > 0$ and $n < 0$ (2) $m < 0$ and $n < 0$.

Explanation of the Root

Definition: If $n \in N, n > 1$ and $a \in R$, if there is such $x \in R$ that $x^n = a$, then this x is called a n -th root of a . If $n = 2$ this root is called square root and for $n = 3$ it is called cube root.

Example 5. 1) 2 and -2 both are the fourth root of 16, as $(2)^4 = 16$ and $(-2)^4 = 16$

- 2) -3 is cube root of -27 , because $(-3)^3 = -27$
- 3) $\forall n \in N, 0$ is the n -th root of 0 . For $n > 1, 0^n = 0$
- 4) -9 has no square root, because square of any real number is non-negative.

It is important to know and remember the following facts,

- (i) If $a > 0$ and $n \in N, n > 1$, then a has a unique positive n -th root. This unique positive root is denoted as $\sqrt[n]{a}$ ($\sqrt[n]{a}$ is replaced with \sqrt{a}) and it is called the principal n -th root of a . If n is an even number, a has another n -th root and that is $-\sqrt[n]{a}$
- (ii) If $a < 0$ and $n \in N, n > 1$ is odd number, then a has only one n -th root which is negative. This root is denoted as $-\sqrt[n]{|a|}$. If n is even and a is negative, a does not have any n -th root.
- (iii) n -th root of 0 is $\sqrt[n]{0} = 0$

Note:

1. If $a > 0, \sqrt[n]{a} > 0$
2. if $a < 0$ and n is odd, $\sqrt[n]{a} = -\sqrt[n]{|a|} < 0$ [where $|a|$ is the absolute value of a]

Example 6. $\sqrt{4} = 2, (\sqrt{4} \neq -2), \sqrt[3]{-8} = -2 = -\sqrt[3]{8},$

$$\sqrt{a^2} = |a| = \begin{cases} a, & \text{when } a \geq 0 \\ -a, & \text{when } a < 0 \end{cases}$$

Formula 7. If $a < 0, n \in N, n > 1$ and n is odd then show that, $\sqrt[n]{a} = -\sqrt[n]{|a|}$

Proof:

$$\begin{aligned} \sqrt[n]{a} &= \sqrt[n]{-|a|} \quad [\because a < 0] \\ &= \sqrt[n]{(-1)^n |a|} \quad [\because n \text{ is odd}] \\ &= -\sqrt[n]{|a|} \end{aligned}$$

$$\text{So, } \sqrt[n]{a} = -\sqrt[n]{|a|}$$

Example 7. Find the value of $-\sqrt[3]{27}$.

Solution: $-\sqrt[3]{27} = -\sqrt[3]{(3)^3} = -3$

Formula 8. If $a > 0, m \in Z$ and $n \in N, n > 1, (\sqrt[n]{a})^m = \sqrt[n]{a^m}$

Proof: Let, $\sqrt[n]{a} = x$ and $\sqrt[n]{a^m} = y$

Then, $x^n = a$ and $y^n = a^m$

or, $y^n = a^m = (x^n)^m = (x^m)^n$

Since $y > 0, x^m > 0$, therefore considering the unique n -th root we get, $y = x^m$

or, $\sqrt[n]{a^m} = (\sqrt[n]{a})^m$

i.e, $(\sqrt[n]{a})^m = \sqrt[n]{a^m}$

Formula 9. If $a > 0$ and $\frac{m}{n} = \frac{p}{q}$, where $m, p \in Z$ and $n, q \in N, n > 1, q > 1$ then, $\sqrt[n]{a^m} = \sqrt[q]{a^p}$

Proof: Here, $qm = pn$

Let, $\sqrt[n]{a^m} = x$ then, $x^n = a^m$

or, $(x^n)^q = (a^m)^q$

or, $x^{nq} = a^{mq} = a^{pn}$

or, $(x^q)^n = (a^p)^n$

or, $x^q = a^p$ [considering the unique n -th root]

or, $x = \sqrt[q]{a^p}$

i.e, $\sqrt[n]{a^m} = \sqrt[q]{a^p}$

Corollary 1. If $a > 0$ and $n, k \in N, n > 1$, then, $\sqrt[n]{a} = \sqrt[nk]{a^k}$

Rational Fractional Exponents

Definition 5: If $a \in R$ and $n \in N, n > 1, a^{\frac{1}{n}} = \sqrt[n]{a}$ when $a > 0$ or $a < 0$ and n are odd.

Remark: Exponent Rule $(a^m)^n = a^{mn}$ [Formula 6]

If it is true in all cases, then $\left(a^{\frac{1}{n}}\right)^n = a^{\frac{n}{n}} = a^1 = a$ needs to happen, i.e n -th root of $a^{\frac{1}{n}}$ needs to happen. So the definition mentioned above is explained to prevent ambiguity for more than one number of roots.

Remark: If $a < 0$ and $n \in N, n > 1$ odd then from formula 7 it is seen that

$$a^{\frac{1}{n}} = \sqrt[n]{a} = -\sqrt[n]{|a|} = -|a|^{\frac{1}{n}}$$

In these cases using this formula, the value of $a^{\frac{1}{n}}$ is determined.

Remark: If a is a rational number, then in most of the cases $a^{\frac{1}{n}}$ will be a rational number too. In these cases, the approximate value of $a^{\frac{1}{n}}$ is used.

Definition 6: If $a > 0, m \in Z$ and $n \in N, n > 1$ $a^{\frac{m}{n}} = (a^{\frac{1}{n}})^m$

Note: From definition 5 and 6 and formula 8 we see that,

$$a^{\frac{m}{n}} = (\sqrt[n]{a})^m = \sqrt[n]{a^m} \text{ where, } a > 0, m \in Z \text{ and, } n \in N, n > 1$$

So, $p \in Z$ and $q \in Z, n > 1$ if such that, $\frac{m}{n} = \frac{p}{q}$ happens, then we can see from formula 9 that, $a^{\frac{m}{n}} = a^{\frac{p}{q}}$

Note: From the definitions of integer exponents and rational fractional exponents, we can get the explanation of a^r , where $a > 0$ and $r \in Q$. From the above discussion we see that if $a > 0$, then if r is divided into equal fractional value, the value of a^r does not change.

Note: The rules explained in formula 6 is generally true for all exponents.

Formula 10. If $a > 0, b > 0$ and $r, s \in Q$

$$1) a^r \cdot a^s = a^{r+s}$$

$$2) \frac{a^r}{a^s} = a^{r-s}$$

$$3) (a^r)^s = a^{rs}$$

$$4) (ab)^r = a^r b^r$$

$$5) \left(\frac{a}{b}\right)^r = \frac{a^r}{b^r}$$

From repeated applications of (a) and (d) we see that,

Corollary 2. If

$$1) a > 0 \text{ and } r_1, r_2, \dots, r_k \in Q,$$

$$a^{r_1} \cdot a^{r_2} \cdot a^{r_3} \dots a^{r_k} = a^{r_1+r_2+r_3+\dots+r_k}.$$

$$2) \text{ If } a_1 > 0, a_2 > 0, \dots, a_n > 0 \text{ and } r \in Q \text{ then } (a_1 \cdot a_2 \dots a_n)^r = a_1^r \cdot a_2^r \dots a_n^r.$$

Example 8. Show that, $a^{\frac{m}{n}} \cdot a^{\frac{p}{q}} = a^{\frac{m}{n} + \frac{p}{q}}$

where, $a > 0; m, p \in Z; n, q \in N, n > 1, q > 1$.

Solution: Transforming $\frac{m}{n}$ and $\frac{p}{q}$ into fractions with same denominator we can see that,

$$\begin{aligned} a^{\frac{m}{n}} \cdot a^{\frac{p}{q}} &= a^{\frac{mq}{nq}} \cdot a^{\frac{np}{nq}} = (a^{\frac{1}{nq}})^{mq} (a^{\frac{1}{nq}})^{np} \text{ [Using definition 6]} \\ &= (a^{\frac{1}{nq}})^{mq+np} \text{ [Formula 6]} \\ &= a^{\frac{mq+np}{nq}} \\ &= a^{\frac{mq}{nq} + \frac{np}{nq}} \\ &= a^{\frac{m}{n} + \frac{p}{q}} \end{aligned}$$

Some Important Facts:

- (i) If $a^x = 1$, where $a > 0$ and $a \neq 1$, then $x = 0$
- (ii) If $a^x = 1$, where $a > 0$ and $x \neq 0$, then $a = 1$
- (iii) If $a^x = a^y$, where $a > 0$ and $a \neq 1$, then $x = y$
- (iv) If $a^x = b^x$, where $\frac{a}{b} > 0$ and $x \neq 0$, then $a = b$

Example 9. If $a^x = b$, $b^y = c$ and $c^z = a$, then show that, $xyz = 1$.

Solution: From the given condition, $b = a^x$, $c = b^y$ and $a = c^z$

$$\text{Now, } b = a^x = (c^z)^x = c^{zx} = (b^y)^{zx} = b^{xyz}$$

$$\text{or, } b = b^{xyz} \text{ or, } b^1 = b^{xyz}$$

$$\therefore xyz = 1$$

Example 10. If $a^b = b^a$, then show that, $\left(\frac{a}{b}\right)^{\frac{a}{b}} = a^{\frac{a}{b}-1}$ and from this prove that, if $a = 2b$, then $b = 2$

Solution: Given that, $a^b = b^a$

$$\therefore b = (a^b)^{\frac{1}{a}} = (a)^{\frac{b}{a}}$$

$$\text{L.H.S.} = \left(\frac{a}{b}\right)^{\frac{a}{b}} = \left(\frac{a}{a^{\frac{b}{a}}}\right)^{\frac{a}{b}} = \left(a^1 \cdot a^{-\frac{b}{a}}\right)^{\frac{a}{b}}$$

$$= a^{\frac{a}{b}} \cdot a^{-1} = a^{\frac{a}{b}-1} = \text{R.H.S. (proved)}$$

Again, if $a = 2b$

$$\left(\frac{2b}{b}\right)^{\frac{2b}{b}} = (2b)^{\frac{2b}{b}-1}$$

$$\text{or, } (2)^2 = (2b)^{2-1} \text{ or, } 4 = 2b$$

$$\therefore b = 2 \text{ (proved)}$$

Example 11. If $x^{x\sqrt{x}} = (x\sqrt{x})^x$, then find the value of x .

Solution: Given that, $x^{x\sqrt{x}} = (x\sqrt{x})^x$

$$\text{or, } (x^x)^{\sqrt{x}} = \left(x \cdot x^{\frac{1}{2}}\right)^x = \left(x^{1+\frac{1}{2}}\right)^x = \left(x^{\frac{3}{2}}\right)^x = (x^x)^{\frac{3}{2}}$$

$$\therefore (x^x)^{\sqrt{x}} = (x^x)^{\frac{3}{2}}$$

$$\text{or, } \sqrt{x} = \frac{3}{2} \text{ or, } x = \left(\frac{3}{2}\right)^2 = \frac{9}{4}$$

$$\therefore x = \frac{9}{4}$$

Example 12. If $a^x = b^y = c^z$ and $b^2 = ac$, then prove that, $\frac{1}{x} + \frac{1}{z} = \frac{2}{y}$.

Solution: Given that, $a^x = b^y$ or, $a = b^{\frac{y}{x}}$

Again, $c^z = b^y$ or, $c = b^{\frac{y}{z}}$

Now, $b^2 = ac$ or, $b^2 = b^{\frac{y}{x}} \cdot b^{\frac{y}{z}} = b^{\frac{y}{x} + \frac{y}{z}}$

$$\text{or, } 2 = \frac{y}{x} + \frac{y}{z}$$

$$\text{or, } \frac{2}{y} = \frac{1}{x} + \frac{1}{z} \text{ [Dividing both sides by } y\text{]}$$

$$\therefore \frac{1}{x} + \frac{1}{z} = \frac{2}{y} \text{ (proved)}$$

Example 13. Prove that, $\left(\frac{x^b}{x^c}\right)^{b+c} \times \left(\frac{x^c}{x^a}\right)^{c+a} \times \left(\frac{x^a}{x^b}\right)^{a+b} = 1$.

$$\text{Solution: L.H.S.} = \left(\frac{x^b}{x^c}\right)^{b+c} \times \left(\frac{x^c}{x^a}\right)^{c+a} \times \left(\frac{x^a}{x^b}\right)^{a+b}$$

$$= (x^{b-c})^{b+c} \times (x^{c-a})^{c+a} \times (x^{a-b})^{a+b}$$

$$= x^{b^2-c^2} \times x^{c^2-a^2} \times x^{a^2-b^2}$$

$$= x^{b^2-c^2+c^2-a^2+a^2-b^2}$$

$$= x^0 = 1 = \text{R.H.S.}$$

Example 14. If $a^{\frac{1}{x}} = b^{\frac{1}{y}} = c^{\frac{1}{z}}$ and $abc = 1$, then show that, $x + y + z = 0$.

Solution: Let, $a^{\frac{1}{x}} = b^{\frac{1}{y}} = c^{\frac{1}{z}} = k$

then we get, $a = k^x, b = k^y, c = k^z$

$$\therefore abc = k^x \cdot k^y \cdot k^z = k^{x+y+z}$$

Given that, $abc = 1$

$$\therefore k^{x+y+z} = 1 = k^0$$

$$\therefore x + y + z = 0$$

Example 15. Simplify $\frac{1}{1 + a^{y-z} + a^{y-x}} + \frac{1}{1 + a^{z-x} + a^{z-y}} + \frac{1}{1 + a^{x-y} + a^{x-z}}$

Solution:

Here,

$$\frac{1}{1 + a^{y-z} + a^{y-x}} = \frac{a^{-y}}{a^{-y}(1 + a^{y-z} + a^{y-x})} = \frac{a^{-y}}{a^{-y} + a^{-z} + a^{-x}}$$

$$\text{Similarly, } \frac{1}{1 + a^{z-x} + a^{z-y}} = \frac{a^{-z}}{a^{-z}(1 + a^{z-x} + a^{z-y})} = \frac{a^{-z}}{a^{-z} + a^{-x} + a^{-y}}$$

$$\text{and } \frac{1}{1 + a^{x-y} + a^{x-z}} = \frac{a^{-x}}{a^{-x} + a^{-y} + a^{-z}}$$

$$\begin{aligned} \text{Hence given quantity} &= \frac{1}{1 + a^{y-z} + a^{y-x}} + \frac{1}{1 + a^{z-x} + a^{z-y}} + \frac{1}{1 + a^{x-y} + a^{x-z}} \\ &= \frac{a^{-y}}{a^{-y} + a^{-z} + a^{-x}} + \frac{a^{-z}}{a^{-z} + a^{-x} + a^{-y}} + \frac{a^{-x}}{a^{-x} + a^{-y} + a^{-z}} \\ &= \frac{a^{-x} + a^{-y} + a^{-z}}{a^{-x} + a^{-y} + a^{-z}} = 1 \end{aligned}$$

Example 16. If $a = 2 + 2^{\frac{2}{3}} + 2^{\frac{1}{3}}$, then show that, $a^3 - 6a^2 + 6a - 2 = 0$

Solution: Given that, $a = 2 + 2^{\frac{2}{3}} + 2^{\frac{1}{3}}$

$$\therefore a - 2 = 2^{\frac{2}{3}} + 2^{\frac{1}{3}}$$

$$\text{or, } (a - 2)^3 = (2^{\frac{2}{3}} + 2^{\frac{1}{3}})^3 = 2^2 + 2 + 3 \cdot 2^{\frac{2}{3}} \cdot 2^{\frac{1}{3}} (2^{\frac{2}{3}} + 2^{\frac{1}{3}}) = 6 + 6(a - 2) [\because 2^{\frac{2}{3}} + 2^{\frac{1}{3}} = a - 2]$$

$$\text{or, } a^3 - 3a^2 \cdot 2 + 3a \cdot 2^2 - 2^3 = 6 + 6a - 12$$

$$\text{or, } a^3 - 6a^2 + 12a - 8 = 6a - 6$$

$$\therefore a^3 - 6a^2 + 6a - 2 = 0$$

Example 17. Solve: $4^x - 3 \cdot 2^{x+2} + 2^5 = 0$

Solution: $4^x - 3 \cdot 2^{x+2} + 2^5 = 0$

$$\text{or, } (2^2)^x - 3 \cdot 2^x \cdot 2^2 + 32 = 0$$

$$\text{or, } (2^x)^2 - 12 \cdot 2^x + 32 = 0$$

$$\text{or, } y^2 - 12y + 32 = 0 \text{ [suppose } 2^x = y]$$

$$\text{or, } y^2 - 4y - 8y + 32 = 0 \text{ or, } y(y - 4) - 8(y - 4) = 0$$

$$\text{or, } (y - 4)(y - 8) = 0$$

$$\text{So, } y - 4 = 0 \text{ or, } y - 8 = 0$$

$$\text{or, } 2^x - 4 = 0 \text{ [}\because 2^x = y] \text{ or, } 2^x - 8 = 0 \text{ [}\because 2^x = y]$$

$$\text{or, } 2^x = 4 = 2^2 \text{ or, } 2^x = 8 = 2^3$$

$$\therefore x = 2 \text{ or, } x = 3$$

$$\therefore \text{ Required solution, } x = 2, 3$$

Activity:

1) Find the value:

$$(1) \frac{5^{n+2} + 35 \times 5^{n-1}}{4 \times 5^n} \qquad (2) \frac{3^4 \cdot 3^8}{3^{14}}$$

2) Show that, $\left(\frac{p^a}{p^b}\right)^{a^2+ab+b^2} \times \left(\frac{p^b}{p^c}\right)^{b^2+bc+c^2} \times \left(\frac{p^c}{p^a}\right)^{c^2+ca+a^2} = 1$.

3) If $a = xy^{p-1}$, $b = xy^{q-1}$ and $c = xy^{r-1}$, then show that

$$a^{q-r} \cdot b^{r-p} \cdot c^{p-a} = 1$$

4) Solve:

$$(1) 4^x - 3^{x-\frac{1}{2}} = 3^{x+\frac{1}{2}} - 2^{2x-1}$$

$$(2) 9^{2x} = 3^{x+1}$$

$$(3) 2^{x+3} + 2^{x+1} = 320$$

5) Simplify:

$$(1) \sqrt[12]{(a^8)\sqrt{(a^6)\sqrt{a^4}}}$$

$$(2) \left[1 - 1\{1 - (1 - x^3)^{-1}\}^{-1}\right]^{-1}$$

6) If $\sqrt{x} = \sqrt[3]{y} = \sqrt[4]{z}$ and $abc = 1$, then prove that, $x + y + z = 0$.

7) If $a^m \cdot a^n = (a^m)^n$, then prove that, $m(n - 2) + n(m - 2) = 0$.

Exercise 9.1

1. Prove that, $\left(a^{\frac{m}{n}}\right)^p = a^{\frac{mp}{n}}$, where $m, p \in Z$ and $n \in N$
2. Prove that, $\left(a^{\frac{1}{m}}\right)^{\frac{1}{n}} = a^{\frac{1}{mn}}$, where $m, n \in Z, m \neq 0, n \neq 0$
3. Prove that, $\left(ab\right)^{\frac{m}{n}} = \left(a\right)^{\frac{m}{n}} \left(b\right)^{\frac{m}{n}}$, where $m \in Z, n \in N$
4. Show that,
 - 1) $\left(a^{\frac{1}{3}} - b^{\frac{1}{3}}\right)\left(a^{\frac{2}{3}} + a^{\frac{1}{3}}b^{\frac{1}{3}} + b^{\frac{2}{3}}\right) = a - b$
 - 2) $\frac{a^3 + a^{-3} + 1}{a^{\frac{3}{2}} + a^{\frac{-3}{2}} + 1} = a^{\frac{3}{2}} + a^{\frac{-3}{2}} - 1$
5. Simplify:

$$1) \frac{\left(\frac{a+b}{b}\right)^{\frac{a}{a-b}} \times \left(\frac{a-b}{a}\right)^{\frac{a}{a-b}}}{\frac{a+b}{b} \times \frac{a-b}{a}}$$

$$2) \frac{a^{\frac{3}{2}} + ab}{ab - b^3} - \frac{\sqrt{a}}{\sqrt{a-b}}$$

$$3) \left\{ \left(x^{\frac{1}{a}}\right)^{\frac{a^2-b^2}{a-b}} \right\}^{\frac{a}{a+b}}$$

$$4) \frac{1}{1 + a^{-m}b^n + a^{-m}c^p} + \frac{1}{1 + b^{-n}c^p + b^{-n}a^m} + \frac{1}{1 + c^{-p}a^m + c^{-p}b^n}$$

$$5) \sqrt[bc]{x^{\frac{b}{c}} \times x^{\frac{c}{b}}} \times \sqrt[ca]{x^{\frac{c}{a}} \times x^{\frac{a}{c}}} \times \sqrt[ab]{x^{\frac{a}{b}} \times x^{\frac{b}{a}}}$$

$$6) \frac{(a^2 - b^{-2})^a (a - b^{-1})^{b-a}}{(b^2 - a^{-2})^b (b + a^{-1})^{a-b}}$$

6. Show that,
 - 1) If $x = a^{q+r}b^p, y = a^{r+p}b^q, z = a^{p+q}b^r$, then $x^{q-r} \cdot y^{r-p} \cdot z^{p-q} = 1$.
 - 2) If $a^p = b, b^q = c$ and $c^r = a$, then $pqr = 1$.
 - 3) If $a^x = p, a^y = q$ and $a^2 = (p^y q^x)^z$, then $xyz = 1$.

7. 1) If $x\sqrt[3]{a} + y\sqrt[3]{b} + z\sqrt[3]{c} = 0$ and $a^2 = bc$, then show that,
 $ax^3 + by^3 + cz^3 = 3axyz$.
- 2) If $x = (a + b)^{\frac{1}{3}} + (a - b)^{\frac{1}{3}}$ and $a^2 - b^2 = c^3$, then show that,
 $x^3 - 3cx - 2a = 0$.
- 3) If $a = 2^{\frac{1}{3}} + 2^{-\frac{1}{3}}$, then show that, $2a^3 - 6a = 5$.
- 4) If $a^2 + 2 = 3^{\frac{2}{3}} + 3^{-\frac{2}{3}}$ and $a \geq 0$, then show that, $3a^3 + 9a = 8$.
- 5) If $a^2 = b^3$, then show that, $\left(\frac{a}{b}\right)^{\frac{2}{3}} + \left(\frac{b}{a}\right)^{\frac{2}{3}} = a^{\frac{1}{2}} + b^{-\frac{1}{3}}$.
- 6) If $b = 1 + 3^{\frac{2}{3}} + 3^{\frac{1}{3}}$, then show that, $b^3 - 3b^2 - 6b - 4 = 0$.
- 7) If $a + b + c = 0$, then show that,

$$\frac{1}{x^b + x^{-c} + 1} + \frac{1}{x^c + x^{-a} + 1} + \frac{1}{x^a + x^{-b} + 1} = 1$$
.
8. 1) If $a^x = b$, $b^y = c$ and $c^z = 1$, then find the value of xyz .
- 2) If $x^a = y^b = z^c$ and $xyz = 1$, then find the value of $ab + bc + ca$.
- 3) If $9^x = 27^y$, then find the value of $\frac{x}{y}$.
9. Solve:
- (1) $3^{2x+2} + 27^{x+1} = 36$ (2) $5^x + 3^y = 8, 5^{x-1} + 3^{y-1} = 2$
- (3) $4^{3y-2} = 16^{x+y}, 3^{x+2y} = 9^{2x+1}$ (4) $2^{2x+1} \cdot 2^{3y+1} = 8, 2^{x+2} \cdot 2^{y+2} = 16$

Logarithm

Logarithm originated from two Greek words Logos and arithmas. Logos means discussion and arithmas means number. So logarithm means discussion about numbers.

Definition: If $a^x = b$, where $a > 0$ and $a \neq 1$ then x is called the logarithm of b to the base a where $x = \log_a b$

Hence, if $a^x = b$, then $x = \log_a b$

On the other hand, if $x = \log_a b$, then $a^x = b$

In this case the number b is the antilogarithm of x with respect to base a and we write, $b = \text{antilog}_a x$

In many cases the bases of log and anti log is not written.

Example 18. $\text{antilog}2.82679 = 671.1042668$

$\text{antilog}(9.82672 - 10) = 0.671$

and $\text{antilog}(6.74429 - 10) = 0.000555$

Note: The approximate value of \log_a can be determined using scientific calculator. (Detailed explanation is given in the mathematics book of class 9-10)

According to the definition, we get,

$\log_2 64 = 6$ as $2^6 = 64$ and $\log_8 64 = 2$ as $8^2 = 64$

Therefore, logarithm of same number can be different based on different bases. Different logarithm values of same number can be determined by taking any number as base which is positive but not 1. Any positive number can be regarded as a base of logarithm. Logarithm values of zero or any negative number can not be determined.

Note: If $a > 0, a \neq 1$ and $b \neq 0$ then logarithm of b with a unique base a can be denoted by $\log_a b$.

Therefore,

- 1) $\log_a b = x$ if and only if $a^x = b$. From (a) we see that,
- 2) $\log_a(a^x) = x$
- 3) $a^{\log_a b} = b$

Example 19. 1) $4^2 = 16 \implies \log_4(16) = 2$

$$2) 5^{-2} = \frac{1}{5^2} = \frac{1}{25} \implies \log_5\left(\frac{1}{25}\right) = -2$$

$$3) 10^3 = 1000 \implies \log_{10}(1000) = 3$$

$$4) 7^{\log_7 9} = 9 \quad [\because a^{\log_a b} = b]$$

$$5) 18 = \log_2(2^{18}) \quad [\because \log_a(a^x) = x]$$

Formulas of Logarithm

Since proofs have been already given in the mathematics book of class 9-10, here only the formulas are shown.

1. $\log_a a = 1$ and $\log_a 1 = 0$
2. $\log_a(M \times N) = \log_a M + \log_a N$

$$3. \log_a \left(\frac{M}{N} \right) = \log_a M - \log_a N$$

$$4. \log_a (M^N) = N \log_a M$$

$$5. \log_a M = \log_b M \times \log_a b \text{ [Formula for changing the base]}$$

Example 20. $\log_2 5 + \log_2 7 + \log_2 3 = \log_2 (5 \cdot 7 \cdot 3) = \log_2 105$

Example 21. $\log_3 20 - \log_3 5 = \log_3 \frac{20}{5} = \log_3 4$

Example 22. $\log_5 64 = \log_5 2^6 = 6 \log_5 2$

Note:

- (i) If $x > 0$, $y > 0$ and $a \neq 1$ then $x = y$ if and only if $\log_a x = \log_a y$
- (ii) If $a > 1$ and $x > 1$ then $\log_a x > 0$
- (iii) If $0 < a < 1$ and $0 < x < 1$ then $\log_a x > 0$
- (iv) If $a > 1$ and $0 < x < 1$ then $\log_a x < 0$

Example 23. Find the value of x when

1) $\log_{\sqrt{8}} x = 3\frac{1}{3}$

2) $\log_{10} [98 + \sqrt{x^2 - 12x + 36}] = 2$

Solution:

1) $\log_{\sqrt{8}} x = 3\frac{1}{3} = \frac{10}{3}$

or, $x = (\sqrt{8})^{\frac{10}{3}} = (\sqrt{2^3})^{\frac{10}{3}}$

or, $x = 2^{\frac{3}{2} \cdot \frac{10}{3}} = 2^5 = 32$

$\therefore x = 32$

2) Since $\log_{10} [98 + \sqrt{x^2 - 12x + 36}] = 2$

or, $98 + \sqrt{x^2 - 12x + 36} = 10^2 = 100$

or, $\sqrt{x^2 - 12x + 36} = 2$

or, $x^2 - 12x + 36 = 4$

or, $x^2 - 12x + 32 = 0$

or, $(x - 4)(x - 8) = 0$

$\therefore x = 4$ or $x = 8$

Example 24. Show that, $a^{\log_k b - \log_k c} \times b^{\log_k c - \log_k a} \times c^{\log_k a - \log_k b} = 1$

Solution: Let, $p = a^{\log_k b - \log_k c} \times b^{\log_k c - \log_k a} \times c^{\log_k a - \log_k b}$

then, $\log_k p = (\log_k b - \log_k c)\log_k a + (\log_k c - \log_k a)\log_k b + (\log_k a - \log_k b)\log_k c$

or, $\log_k p = 0$ or $p = k^0 = 1$

$\therefore a^{\log_k b - \log_k c} \times b^{\log_k c - \log_k a} \times c^{\log_k a - \log_k b} = 1$

Example 25. Show that, $x^{\log_a y} = y^{\log_a x}$

Solution: Let $p = \log_a y$, $q = \log_a x$

Therefore $a^p = y$, $a^q = x$

$\therefore (a^p)^q = y^q$ or $y^q = a^{pq}$

and $(a^q)^p = x^p$ or $x^p = a^{pq}$

$\therefore x^p = y^q$ or $x^{\log_a y} = y^{\log_a x}$

Example 26. Show that, $\log_a p \times \log_p q \times \log_q r \times \log_r b = \log_a b$

Solution: L.H.S. = $\log_a p \times \log_p q \times \log_q r \times \log_r b$

= $(\log_a p \times \log_p q) \times (\log_q r \times \log_r b)$

= $\log_a q \times \log_q b = \log_a b =$ R.H.S.

Example 27. Show that, $\frac{1}{\log_a(abc)} + \frac{1}{\log_b(abc)} + \frac{1}{\log_c(abc)} = 1$

Solution: Let, $\log_a(abc) = x$, $\log_b(abc) = y$, $\log_c(abc) = z$

Therefore, $a^x = abc$, $b^y = abc$, $c^z = abc$

$\therefore a = (abc)^{\frac{1}{x}}$, $b = (abc)^{\frac{1}{y}}$, $c = (abc)^{\frac{1}{z}}$

Now, $(abc)^1 = abc = (abc)^{\frac{1}{x}}(abc)^{\frac{1}{y}}(abc)^{\frac{1}{z}} = (abc)^{\frac{1}{x} + \frac{1}{y} + \frac{1}{z}}$

$\therefore \frac{1}{x} + \frac{1}{y} + \frac{1}{z} = 1$

i.e $\frac{1}{\log_a(abc)} + \frac{1}{\log_b(abc)} + \frac{1}{\log_c(abc)} = 1$

Example 28. If $p = \log_a(bc)$, $q = \log_b(ca)$, $r = \log_c(ab)$, then show that,

$$\frac{1}{p+1} + \frac{1}{q+1} + \frac{1}{r+1} = 1$$

Solution: $1 + p = 1 + \log_a(bc) = \log_a a + \log_a(bc) = \log_a(abc)$

Similarly, $1 + q = \log_b(abc)$ and $1 + r = \log_c(abc)$

Using the result of the previous example, $\frac{1}{\log_a(abc)} + \frac{1}{\log_b(abc)} + \frac{1}{\log_c(abc)} = 1$

$$\therefore \frac{1}{p+1} + \frac{1}{q+1} + \frac{1}{r+1} = 1$$

Example 29. If $\frac{\log a}{y-z} = \frac{\log b}{z-x} = \frac{\log c}{x-y}$ then show that, $a^x b^y c^z = 1$

Solution: Let, $\frac{\log a}{y-z} = \frac{\log b}{z-x} = \frac{\log c}{x-y} = k$

Then, $\log a = k(y-z)$, $\log b = k(z-x)$, $\log c = k(x-y)$

$$\therefore x \log a + y \log b + z \log c = k(xy - zx + yz - xy + zx - yz) = 0$$

$$\text{or, } \log a^x + \log b^y + \log c^z = 0$$

$$\text{or, } \log(a^x b^y c^z) = 0$$

$$\text{or, } \log(a^x b^y c^z) = \log 1 \quad [\because \log 1 = 0]$$

$$\therefore a^x b^y c^z = 1$$

Activity:

- 1) If $\frac{\log a}{b-c} = \frac{\log b}{c-a} = \frac{\log c}{a-b}$ then find the value of $a^a \cdot b^b \cdot c^c$
- 2) If a, b, c are three consecutive integers, then prove that,
 $\log(1+ac) = 2\log b$
- 3) If $a^2 + b^2 = 7ab$ then show that,
 $\log\left(\frac{a+b}{3}\right) = \frac{1}{2}\log(ab) = \frac{1}{2}(\log a + \log b)$
- 4) If $\log\left(\frac{x+y}{3}\right) = \frac{1}{2}(\log x + \log y)$ then show that, $\frac{x}{y} + \frac{y}{x} = 7$
- 5) If $x = 1 + \log_a(bc)$, $y = 1 + \log_b(ca)$ and $z = 1 + \log_c(ab)$ then show that, $xyz = xy + yz + zx$
- 6) If $2\log_8(A) = p$, $2\log_2(2A) = q$ and $q - p = 4$ then find the value of A .

Exponential, Logarithmic and Absolute Value Functions

In the first chapter, we learnt about function, in this chapter we shall know about Exponential, Logarithmic and Absolute Value Functions.

Exponential Function

Observe the following three tables of corresponding values of x and y :

Table 1

x	-2	-1	0	1	2	3
y	-4	-2	0	2	4	6

Table 2

x	0	1	2	3	4	5
y	0	1	4	9	16	25

Table 3

x	0	1	2	3	4	5	6	7	8	9	10
x	1	2	4	8	16	32	64	128	256	512	1024

In Table 1, for different values of x we get values of y of equal differences, complying with the function $y = 2x$. This is an equation of straight line.

In Table 2, the same happens complying with the function $y = x^2$.

In Table 3, the same is true for $y = 2^x$.

Exponential function $f(x) = a^x$ is true for all real number x . Here, $a > 0$ and $a \neq 1$. For example, $y = 2^x$, 10^x , x^x , e^x are exponential functions.

Note: The domain of exponential function $f(x) = a^x$ is $(-\infty, \infty)$ and range is $(0, \infty)$

Activity:

1) Write the exponential function described in the following table:

(1)

x	-2	-1	0	1	2
y	$\frac{1}{4}$	$\frac{1}{2}$	1	2	4

(2)

x	-1	0	1	2	3
y	-3	0	3	6	9

(3)

x	1	2	3	4	5
y	4	16	64	256	1024

(4)

x	-3	-2	-1	0	1
y	0	1	2	3	4

(5)

x	-2	-1	0	1	2
y	$\frac{1}{25}$	$\frac{1}{5}$	1	5	25

(6)

x	1	2	3	4	5
y	5	10	15	20	25

2) Which of the following functions are exponential functions?

- (1) $y = -3^x$ (2) $y = 3x$ (3) $y = -2x - 3$
 (4) $y = 5 - x$ (5) $y = x^2 + 1$ (6) $y = 3x^2$

Graph of Function $f(x) = 2^x$

To draw the graph of given function, we list the values of y for some corresponding x values.

x	-3	-2	-1	0	1	2
y	$\frac{1}{8}$	$\frac{1}{4}$	$\frac{1}{2}$	1	2	4

Plotting the ordered pair (x, y) in the graph we have this graph.

notice the figure:

(i) If x is negative and $|x|$ is large enough, y tends to zero, even though it's never exactly zero. i.e., if $x \rightarrow -\infty$ then $y \rightarrow 0$.

(ii) If x is positive and $|x|$ is large enough, y is large enough. i.e. if $x \rightarrow \infty$ then $y \rightarrow \infty$.

We understand from this, range of the function $f(x) = 2^x$ is $(0, \infty)$.

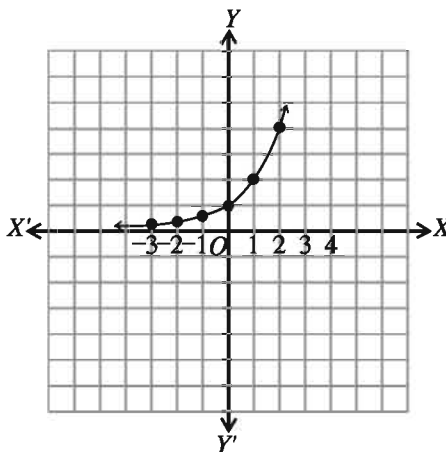

Activity: Draw the graph where $-3 \leq x \leq 3$

1) $y = 2^{-x}$

2) $y = 4^x$

3) $y = 2^{\frac{x}{2}}$

4) $y = \left(\frac{3}{2}\right)^x$

Logarithmic Function

As exponential function is a one-one function, hence it has an inverse function.

Inverse function of $f(x) = y = a^x$ is $f^{-1}(y) = x = \log_a y$

i.e x is y 's a based logarithm.

Definition: Logarithmic function is defined by $f(x) = \log_a x$ where $a > 0$ and $a \neq 1$.

such as, $f(x) = \log_3 x, \log_e x, \log_{10} x$ etc are logarithmic functions

Drawing graph of $y = \log_2 x$

as $y = \log_2 x$ hence, with respect to the inverse function of $y = 2^x$, $y = x$ the reflection of exponential function is determined which is logarithmic function and symmetrical with $y = x$.

Here, domain $R = (0, \infty)$ and range $D = (-\infty, \infty)$

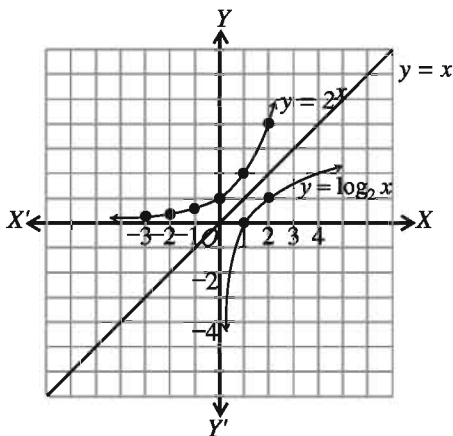

Activity: Draw the graphs of these functions below and determine their inverse functions

1) $y = 3x + 2$

2) $y = x^2 + 3, x \geq 0$

3) $y = x^3 - 1$

4) $y = \frac{4}{x}$

5) $y = 3x$

6) $y = \frac{2x + 1}{x - 1}$

7) $y = 2^{-x}$

8) $y = 4^x$

Example 30. $f(x) = \frac{x}{|x|}$ Determine the function's domain and range.

Solution: $f(0) = \frac{0}{|0|} = \frac{0}{0}$ which is undefined.

\therefore the function is not defined at $x = 0$ point, but is defined at any other point.

\therefore Domain of the function $D_f = R - \{0\}$

$$f(x) = \frac{x}{|x|} = \begin{cases} \frac{x}{x} = 1, & \text{when } x > 0 \\ \frac{x}{-x} = -1, & \text{when } x < 0 \end{cases}$$

\therefore range of the function $R_f = \{-1, 1\}$

Example 31. $y = f(x) = \ln \frac{a+x}{a-x}$, $a > 0$ and integer, determine the domain and range of the function.

Solution: As logarithm is defined only for positive integers.

$$\therefore \frac{a+x}{a-x} > 0 \text{ if}$$

$$(i) \ a + x > 0 \text{ and } a - x > 0 \text{ or}$$

$$(ii) \ a + x < 0 \text{ and } a - x < 0$$

$$(i) \implies x > -a \text{ and } a > x$$

$$\implies -a < x \text{ and } x < a$$

$$\therefore \text{domain} = \{x : -a < x\} \cap \{x : x < a\}$$

$$= (-a, \infty) \cap (-\infty, a) = (-a, a)$$

$$(ii) \implies x < -a \text{ and } a < x$$

$$\implies x < -a \text{ and } x > a$$

$$\therefore \text{domain} = \{x : x < -a\} \cap \{x : x > a\} = \emptyset.$$

\therefore We get from the domain of the given function $D_f = (i)$, and $(ii) \ (-a, a) \cup \emptyset = (-a, a)$

$$\text{range: } y = f(x) = \ln \frac{a+x}{a-x} \implies e^y = \frac{a+x}{a-x}$$

$$\implies a+x = ae^y - xe^y$$

$$\implies x + xe^y = ae^y - a$$

$$\implies (1 + e^y)x = a(e^y - 1)$$

$$\implies x = \frac{a(e^y - 1)}{e^y + 1}$$

x is real for all real values of y

\therefore Range of the given function $R_f = R$

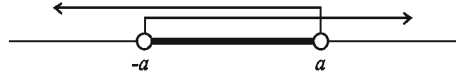

Activity: Determine the domain and range of the function:

$$1) \ y = \ln \frac{2+x}{2-x}$$

$$2) \ y = \ln \frac{3+x}{3-x}$$

$$3) \ y = \ln \frac{4+x}{4-x}$$

$$4) \ y = \ln \frac{5+x}{5-x}$$

Absolute Value

In mathematics book of class 9-10 absolute value is discussed elaborately, here only definition is given.

For any real number x is zero, positive or negative. But absolute value of x is always zero or positive. Absolute value of x is expressed by $|x|$ and defined as:

$$|x| = \begin{cases} x, & \text{when } x \geq 0 \\ -x, & \text{when } x < 0 \end{cases}$$

Example 32. $|0| = 0$, $|3| = 3$, $|-3| = -(-3) = 3$

Absolute Value Function

If $x \in R$ then

$$y = f(x) = |x| = \begin{cases} x & \text{when } x \geq 0 \\ -x & \text{when } x < 0 \end{cases}$$

\therefore Domain $D_f = R$ and range $R_f = [0, \infty)$

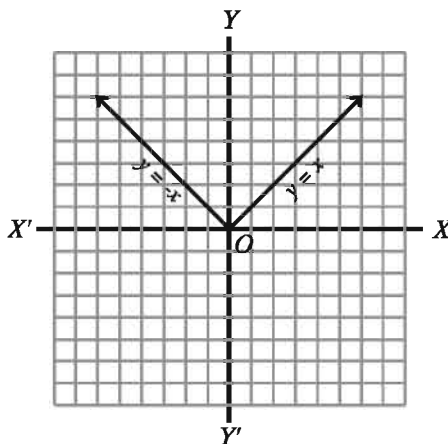

Example 33. $f(x) = e^{-\frac{|x|}{2}}$ when $-1 < x < 0$. Determine domain and range.

Solution: $f(x) = e^{-\frac{|x|}{2}}$, $-1 < x < 0$

x 's value is between -1 to 0

Therefore, domain $D_f = (-1, 0)$

again, in the interval $-1 < x < 0$, $f(x) \in (e^{-\frac{1}{2}}, 1)$

so, range $f = (e^{-\frac{1}{2}}, 1)$

Graphs of Function

Function is detected by representing geometrically in a plane. This geometrical representation is the drawing of graphs. Here we discussed the method of drawing graphs of exponential, logarithmic and absolute value function.

(1) Draw the graph of $y = f(x) = a^x$:

(i) when $a > 1$ and x is any real number then; $f(x) = a^x$ is always positive.

Step 1. For positive value of x , the value of $f(x)$ is increased with the increase of x .

Step 2. When $x = 0$, $y = a^0 = 1$, therefore, $(0, 1)$ is a point on the line.

Step 3. For negative value of x , the value of $f(x)$ is decreased with the increase of x . i.e if $x \rightarrow -\infty$ then $y \rightarrow 0$.

Here, the graph of function $y = a^x$, $a > 1$ is shown beside. Here $D_f = (-\infty, \infty)$ and $R_f = (0, \infty)$.

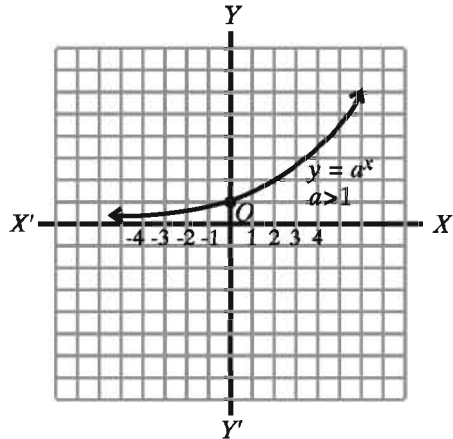

(ii) When $0 < a < 1$, x is real, then $y = f(x) = a^x$ is always positive.

Step 1. Observe if the value of x is increasing from the right side of origin, i.e if $x \rightarrow \infty$ then $y \rightarrow 0$.

Step 2. When $x = 0$ then $y = a^0 = 1$ hence $(0, 1)$ lies on the line.

Step 3. When $a < 1$, the value of x is negative and monotone increasing to the left side from the origin then y is monotone increasing. i.e $y \rightarrow \infty$.

Let, $a = \frac{1}{2} < 1$, $x = -2, -3, \dots, -n$ then

$$y = f(x) = a^x = \left(\frac{1}{2}\right)^{-2} = 2^2, y = 2^3, \dots,$$

$y = 2^n$. When $n \rightarrow \infty$ then graph of $y \rightarrow \infty$.

$y = f(x) = a^x$ is shown beside.

Here $D_f = (-\infty, \infty)$ and $R_f = (0, \infty)$.

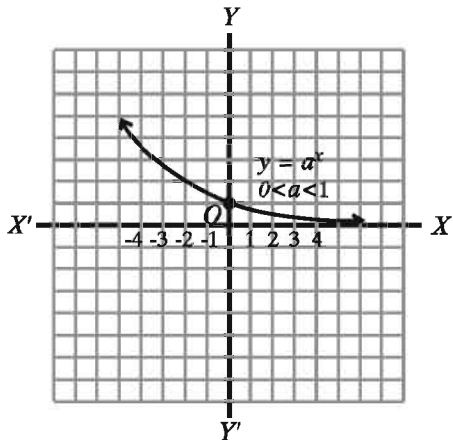

Activity: Sketch the graphs of the following functions; mention their domains and ranges:

1) $f(x) = 2^x$

2) $f(x) = \left(\frac{1}{2}\right)^x$

3) $f(x) = e^x$, $2 < e < 3$

4) $f(x) = e^{-x}$, $2 < e < 3$

5) $f(x) = 3^x$

(2) Sketch the graph of $f(x) = \log_a x$:

(i) Let, $y = f(x) = \log_a x$ when $0 < a < 1$. the function can be written as $x = a^y$

Step 1. When y 's positive value is increasing and increasing, i.e. $y \rightarrow \infty$ then x tends to zero, i.e. $x \rightarrow 0$.

Step 2. As $a^0 = 1$ hence $y = \log_a 1 = 0$, So the line goes through $(1, 0)$.

Step 3. The negative value of y , i.e. y decreases below origin point, i.e. $y \rightarrow -\infty$ then, x increases continuously, i.e. $x \rightarrow \infty$.

In the figure beside, $y = \log_a x$, $0 < a < 1$ is shown. Here $D_f = (0, \infty)$ and $R_f = (-\infty, \infty)$.

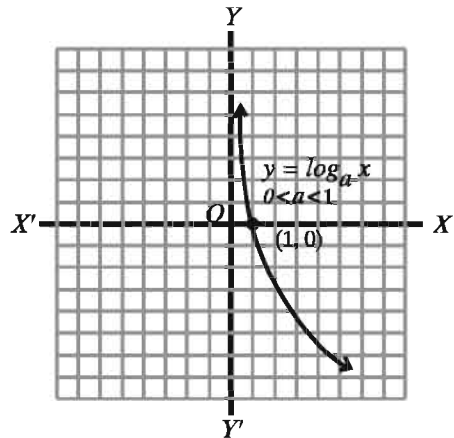

(ii) when $y = \log_a x$, $a > 1$ then

Step 1. When $a > 1$, for all y , x is positive and with increasing values of y , x increases. i.e. if $y \rightarrow \infty$ then $x \rightarrow \infty$.

Step 2. As $a^0 = 1$ hence $y = \log 1 = 0$ So, the line passes through $(1, 0)$

Step 3. If for negative values of y , y keeps increasing i.e., if $y \rightarrow -\infty$ then x tends to zero. i.e. $x \rightarrow 0$.

Now, graph of $f(x) = \log_a x$, $a > 1$ is shown here Here $D_f = (0, \infty)$ and $R_f = (-\infty, \infty)$

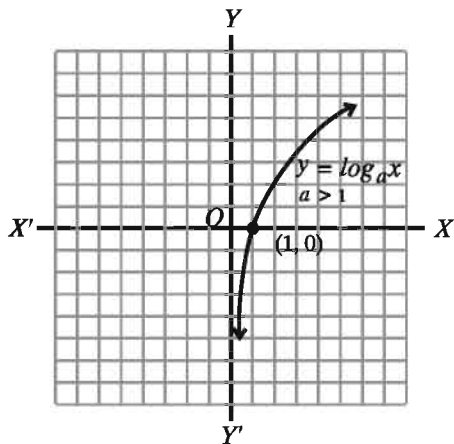

Example 34. Draw the graph of $f(x) = \log_{10} x$

Solution: Let $y = f(x) = \log_{10} x$

As $10^0 = 1$ hence $y = \log_{10} 1 = 0$ So, the line passes through $(1, 0)$. When $x \rightarrow 0$ then $y \rightarrow -\infty$. When $x \rightarrow \infty$ then $y \rightarrow \infty$.

$\therefore y = \log_{10} x$ goes upwards.

The graph is drawn below:

Here $D_f = (0, \infty)$ and $R_f = (-\infty, \infty)$.

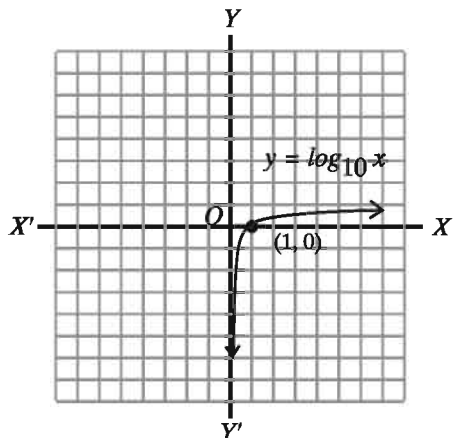

Example 35. Sketch the graph of $f(x) = \ln x$

Solution: Let $y = f(x) = \ln x$

As $e^0 = 1$ hence $y = \ln 1 = 0$ So, the line passes through $(1, 0)$ When $x \rightarrow 0$ then $y \rightarrow -\infty$. When $x \rightarrow \infty$ then $y \rightarrow \infty$.

$\therefore y = \ln x$ goes upwards.

The graph is sketched here.

Here $D_f = (0, \infty)$ and $R_f = (-\infty, \infty)$.

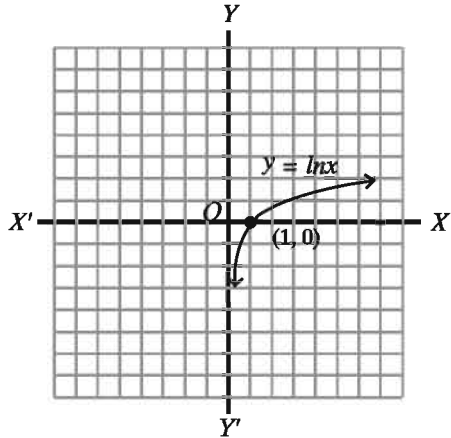

Example 36. $y = \frac{4-x}{4+x}$ is a function.

- 1) Determine the domain of the function.
- 2) Determine its inverse function.
- 3) If $g(x) = \ln y$, then determine the domain of $g(x)$.

Solution:

1) Given, $y = \frac{4-x}{4+x}$

Here $4+x=0$ i.e if $x=-4$ then y is undefined.

$$\therefore x \neq -4$$

$$\therefore \text{Domain of function} = R - \{-4\}$$

2) Given, $y = \frac{4-x}{4+x}$

$$\text{Let, } f(x) = y \therefore x = f^{-1}(y)$$

$$\text{Now, } y = \frac{4-x}{4+x}$$

$$\text{or, } 4y + xy = 4 - x$$

$$\text{or, } xy + x = 4 - 4y$$

$$\text{or, } x(y+1) = 4(1-y)$$

$$\text{or, } x = \frac{4(1-y)}{1+y}$$

$$\text{or, } f^{-1}(y) = \frac{4(1-y)}{1+y} \quad [\because x = f^{-1}(y)]$$

$$\therefore f^{-1}(x) = \frac{4(1-x)}{(1+x)} \quad [\text{Changing the variable}]$$

3) Given, $g(x) = \ln(y)$

$$\therefore g(x) = \ln \frac{4-x}{4+x} \quad [\because y = \frac{4-x}{4+x}]$$

$$\therefore g(x) \in R \text{ if } \frac{4-x}{4+x} > 0$$

$$\text{Now } \frac{4-x}{4+x} > 0 \text{ if}$$

$$(i) 4-x > 0 \text{ and } 4+x > 0 \text{ or}$$

$$(ii) 4-x < 0 \text{ and } 4+x < 0$$

$$\text{Now } (i) \implies x < 4 \text{ and } x > -4$$

$$\therefore \text{Domain} = \{x \in R : x < 4\} \cap \{x \in R : x > -4\} = (-\infty, 4) \cap (-4, \infty) = (-4, 4)$$

$$\text{again, } (ii) \implies x > 4 \text{ and } x < -4$$

$$\therefore \text{Domain} = \{x \in R : x > 4\} \cap \{x \in R : x < -4\} = (4, \infty) \cap (-\infty, 4) = \emptyset$$

$$\therefore \text{Domain of the given function} = (-4, 4) \cup \emptyset = (-4, 4)$$

Activity:

- 1) Sketch the graph of $y = \log_{10}x$ using values of x and y from the table.

x	0.5	1	2	3	4	5	10	12
y	-0.3	0	0.3	0.5	0.6	0.7	1	1.07

- 2) To sketch the graph of $y = \log_e x$, make a table like it was done for (A) using values of x and y , and then sketch the graph.

Exercise 9.2

- Which is the simplest form of the expression $\left\{ \left(x^{\frac{1}{a}} \right)^{\frac{a^2-b^2}{a-b}} \right\}^{\frac{a}{a+b}}$?
 1) 0 2) 1 3) a 4) x
- If $a, b, p > 0$ and $a \neq 1, b \neq 1$ then
 - $\log_a P = \log_b P \times \log_a b$
 - $\log_a \sqrt{a} \times \log_b \sqrt{b} \times \log_c \sqrt{c}$'s value is 2
 - $x^{\log_a y} = y^{\log_a x}$

Which combination of these statements is correct?

- 1) i and ii 2) ii and iii 3) i and iii 4) i, ii and iii

Answer questions 3-5 when $x, y, z \neq 0$ and $a^x = b^y = c^z$

3. Which is correct?

- 1) $a = b^{\frac{y}{z}}$ 2) $a = c^{\frac{z}{y}}$ 3) $a = c^{\frac{z}{x}}$ 4) $a \neq \frac{b^2}{c}$

4. Which of the followings is equal to ac ?

- 1) $b^{\frac{y}{x}} \cdot b^{\frac{y}{z}}$ 2) $b^{\frac{y}{x}} \cdot b^{\frac{z}{y}}$ 3) $b^{\frac{y}{x} + \frac{z}{y}}$ 4) $b^{\frac{z}{y} + \frac{y}{z}}$

5. If $b^2 = ac$, which one is correct?

- 1) $\frac{1}{x} + \frac{1}{z} = \frac{2}{y}$ 2) $\frac{1}{x} + \frac{1}{y} = \frac{2}{z}$ 3) $\frac{1}{y} + \frac{1}{z} = \frac{2}{x}$ 4) $\frac{1}{x} + \frac{1}{y} = \frac{z}{2}$

6. Show that,

1) $\log_k \left(\frac{a^n}{b^n} \right) + \log_k \left(\frac{b^n}{c^n} \right) + \log_k \left(\frac{c^n}{a^n} \right) = 0$

2) $\log_k(ab) \log_k \left(\frac{a}{b} \right) + \log_k(bc) \log_k \left(\frac{b}{c} \right) + \log_k(ca) \log_k \left(\frac{c}{a} \right) = 0$

3) $\log_{\sqrt{a}} b \times \log_{\sqrt{b}} c \times \log_{\sqrt{c}} a = 8$

4) $\log_a \log_a \log_a \left(a^{a^a} \right) = b$

7. 1) If $\frac{\log_k a}{b-c} = \frac{\log_k b}{c-a} = \frac{\log_k c}{a-b}$ then show that, $a^a b^b c^c = 1$

2) If $\frac{\log_k a}{y-z} = \frac{\log_k b}{z-x} = \frac{\log_k c}{x-y}$ then show that,

(1) $a^{y+z} b^{z+x} c^{x+y} = 1$

(2) $a^{y^2+yz+z^2} \cdot b^{z^2+zx+x^2} \cdot c^{x^2+xy+y^2} = 1$

3) If $\frac{\log_k(1+x)}{\log_k x} = 2$ then show that, $x = \frac{1+\sqrt{5}}{2}$

4) Show that, $\log_k \frac{x - \sqrt{x^2 - 1}}{x + \sqrt{x^2 - 1}} = 2 \log_k (x - \sqrt{x^2 - 1})$

5) If $a^{3-x} b^{5x} = a^{5+x} b^{3x}$ then show that, $x \log_k \left(\frac{b}{a} \right) = \log_k a$

6) If $xy^{a-1} = p, xy^{b-1} = q, xy^{c-1} = r$ then show that,

$$(b-c) \log_k p + (c-a) \log_k q + (a-b) \log_k r = 0$$

- 7) If $\frac{ab \log_k(ab)}{a+b} = \frac{bc \log_k(bc)}{b+c} = \frac{ca \log_k(ca)}{c+a}$ then show that,
 $a^a = b^b = c^c$
- 8) If $\frac{x(y+z-x)}{\log_k x} = \frac{y(z+x-y)}{\log_k y} = \frac{z(x+y-z)}{\log_k z}$ then show that,
 $x^y y^x = y^z z^y = z^x x^z$
8. Sketch the graph:
- 1) $y = 3^x$ 2) $y = -3^x$ 3) $y = 3^{x+1}$
 4) $y = -3^{x+1}$ 5) $y = 3^{-x+1}$ 6) $y = 3^{x-1}$
9. Write down the inverse function in each case, mention the domain and range and sketch the graph:
- 1) $y = 1 - 2^x$ 2) $y = \log_{10} x$ 3) $y = x^2, x > 0$
10. Determine $f(x) = \ln(x-2)$ function's domain D_f and range R_f .
11. Determine $f(x) = \ln \frac{1-x}{1+x}$ function's domain and range.
12. Sketch the graph mentioning domain and range:
- 1) $f(x) = |x|$, when $-5 \leq x \leq 5$
 2) $f(x) = x + |x|$, when $-2 \leq x \leq 2$
 3) $f(x) = \begin{cases} \frac{|x|}{x}, & \text{when } x \neq 0 \\ 0, & \text{when } x = 0 \end{cases}$
13. Given, $2^{2x} \cdot 2^{y-1} = 64 \dots (i)$ and $6^x \cdot \frac{6^{y-2}}{3} = 72 \dots (ii)$
- 1) Convert (i) and (ii) into linear equation of x and y .
 2) Solve the equations and verify them.
 3) Should x and y be lengths of two adjacent sides of a quadrilateral and the angle included them be 90° , state whether the quadrilateral would be a rectangle or a square; find its area and the lengths of the diagonals.
14. Given, $y = 2^x$
- 1) Mention the domain and range of the function.
 2) Draw the graph of the function, and mention its salient features.
 3) State whether the given function has an inverse function. If so, is it one-one? Sketch the graph of the inverse function.

15. $f(x) = 3^{2x+2}$ and $g(x) = 27^{x+1}$

1) Find the domain of $f(x)$.

2) If $f(x) + g(x) = 36$ then find the value of x .

3) If $q(x) = \frac{g(x)}{f(x)}$ then, sketch the graph of $q(x)$ and determine domain and range.

Chapter 10

Binomial Expansion

In our previous classes, addition, subtraction, multiplication, division, square and cube related algebraic expressions (single term, binomial and polynomial) had been discussed. When the power of a binomial or a polynomial expression is more than three, determining the value of such expression is labourious and time consuming. In this chapter, the working method will be presented in case of power being more than three. Generally, formula will be demonstrated for the power of n , by which the value of binomial expression of non negative integer of power will be possible to determine. But at this stage the value of n will not exceed a definite limit ($n \leq 8$). A triangle will be introduced called Pascal's Triangle so that students can easily understand and use the subject matter. The power of binomial expression may be a positive or negative integer or fraction. But our present discussion will be limited to only positive integer of power. In higher classes detailed discussion will be included.

After completing this chapter, the students will be able to-

- ▶ describe the binomial expression;
- ▶ describe the Pascal's triangle;
- ▶ describe the binomial expression for general power;
- ▶ find the value of $n!$ and ${}^n C_r$;
- ▶ solve mathematical problems using binomial expression.

Binomial Expansion of $(1 + y)^n$

An algebraic expression consisting of two terms is called a binomial expression. $a + b$, $x - y$, $1 + x$, $1 - x^2$, $a^2 - b^2$ etc are binomial expressions. We first consider a binomial expression of $(1 + y)$. Now we multiply $(1 + y)$ by $(1 + y)$ successively then we get $(1 + y)^2$, $(1 + y)^3$, $(1 + y)^4$, $(1 + y)^5$, \dots etc. We know,

$$(1 + y)^2 = (1 + y)(1 + y) = 1 + 2y + y^2$$

$$(1 + y)^3 = (1 + y)(1 + y)^2 = (1 + y)(1 + 2y + y^2) = 1 + 3y + 3y^2 + y^3$$

Similarly it is possible to determine the value of $(1 + y)^4$, $(1 + y)^5$, \dots etc by the process of lengthy multiplication. But it will be lengthy and time consuming if the powers of $(1 + y)$ is increasing. So it will be better to find out a method to easily determine the expansion of $(1 + y)^n$ for any powers (say n) of $(1 + y)$. For $n = 0, 1, 2, 3, 4, \dots$ i.e., for non negative values of n , our discussion is limited in this context. Now we carefully observe the procedure.

Value of n		Pascal's Triangle	Number of Terms
$n = 0$	$(1 + y)^0 =$	1	1
$n = 1$	$(1 + y)^1 =$	$1 + y$	2
$n = 2$	$(1 + y)^2 =$	$1 + 2y + y^2$	3
$n = 3$	$(1 + y)^3 =$	$1 + 3y + 3y^2 + y^3$	4
$n = 4$	$(1 + y)^4 =$	$1 + 4y + 6y^2 + 4y^3 + y^4$	5
$n = 5$	$(1 + y)^5 =$	$1 + 5y + 10y^2 + 10y^3 + 5y^4 + y^5$	6

On the basis of the above expressions, we come to the decision of the expansion of $(1 + y)^n$.

- 1) In the expansion of $(1 + y)^n$ the number of term is $(n + 1)$ i.e. number of terms is greater than power.
- 2) The power of y is increasing from zero to 1, 2, 3, \dots , n i.e. power of y is increasing orderly up to n .

Binomial coefficient

The coefficient of different powers of y on the above expansion is called Binomial Coefficients. 1 is considered as the coefficient of y . If we arrange the coefficients of the above expansion,

$n = 0$	1					
$n = 1$	1	1				
$n = 2$	1	2	1			
$n = 3$	1	3	3	1		
$n = 4$	1	4	6	4	1	
$n = 5$	1	5	10	10	5	1

If we observe we see, the coefficients have formed a triangular shape. The technique of determining the coefficients of binomial expansion was first used by Blaise Pascal. So it is called Pascal's Triangle. We can easily determine the coefficients of binomial expansion by pascal's triangle.

Use of Pascal's Triangle

From Pascal's Triangle, we see that 1 is in both left and right side. The middle term of the triangle is the summation of two number just above the numbers. If we observe the following example, we can easily understand it.

Binomial coefficients for $n = 5$ $n = 6$ will be:

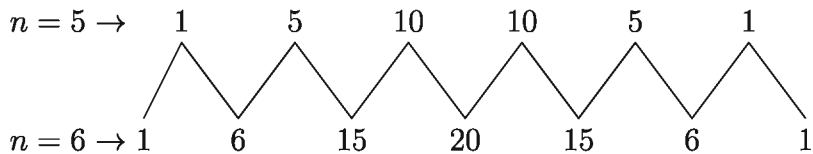

$$\therefore (1 + y)^5 = 1 + 5y + 10y^2 + 10y^3 + 5y^4 + y^5$$

$$\therefore (1 + y)^6 = 1 + 6y + 15y^2 + 20y^3 + 15y^4 + 6y^5 + y^6$$

$$(1 + y)^7 = 1 + 7y + 21y^2 + 35y^3 + 35y^4 + 21y^5 + 7y^6 + y^7$$

Activity: Find the expansion of the following (using the above expansions):

$$(1 + y)^8 =$$

$$(1 + y)^9 =$$

$$(1 + y)^{10} =$$

If we observe carefully, we will understand that this method has a special weakness. For example, if we are to determine the expansion of $(1 + y)^5$, we need to know the expansion of $(1 + y)^4$. Again it is necessary to know preceding two coefficients just above for any binomial coefficients. To get relief from this position we want to directly find out the technique for determining the binomial coefficients. From Pascal's Triangle we see that the power of coefficient of binomial expansion depends on power n and position of the term. We consider a new symbol $\binom{n}{r}$ where the power n and the position of the term r are related. For example if $n = 4$, the number of terms will be 5. We write the terms like this:

When $n = 4$, number of terms is 5: T_1, T_2, T_3, T_4, T_5

Coefficients of them are : 1, 4, 6, 4, 1

Using new symbol: $\binom{4}{0}$, $\binom{4}{1}$, $\binom{4}{2}$, $\binom{4}{3}$, $\binom{4}{4}$

$$\text{Here, } \binom{4}{0} = 1, \binom{4}{1} = \frac{4}{1} = 4, \binom{4}{2} = \frac{4 \times 3}{1 \times 2} = 6, \binom{4}{3} = \frac{4 \times 3 \times 2}{1 \times 2 \times 3} = 4,$$

$$\binom{4}{4} = \frac{4 \times 3 \times 2 \times 1}{1 \times 2 \times 3 \times 4} = 1$$

[You will understand easily from Pascal's triangle.]

Using new symbol ($n = 1, 2, 3, \dots$) Pascal's Triangle will be like this:

$n = 1$	$\binom{1}{0}$	$\binom{1}{1}$				
$n = 2$	$\binom{2}{0}$	$\binom{2}{1}$	$\binom{2}{2}$			
$n = 3$	$\binom{3}{0}$	$\binom{3}{1}$	$\binom{3}{2}$	$\binom{3}{3}$		
$n = 4$	$\binom{4}{0}$	$\binom{4}{1}$	$\binom{4}{2}$	$\binom{4}{3}$	$\binom{4}{4}$	
$n = 5$	$\binom{5}{0}$	$\binom{5}{1}$	$\binom{5}{2}$	$\binom{5}{3}$	$\binom{5}{4}$	$\binom{5}{5}$

Therefore from the triangle above we can easily say that coefficient of third term (T_{2+1}) of $(1+y)^4$ is $\binom{4}{2}$ and coefficient of third (T_{2+1}) and fourth (T_{3+1}) of $(1+y)^5$ are $\binom{5}{2}$ and $\binom{5}{3}$ respectively. Generally, coefficients of $(r+1)$ th term (T_{r+1}) of $(1+y)^n$ is $\binom{n}{r}$.

Now, to know the value of $\binom{n}{r}$, we again observe the Pascal's Triangle. From the two sides of Pascal's Triangle, we see that

$$\binom{1}{0} = 1, \binom{2}{0} = 1, \binom{3}{0} = 1, \dots, \binom{n}{0} = 1$$

$$\binom{1}{1} = 1, \binom{2}{1} = 2, \binom{3}{1} = 3, \dots, \binom{n}{1} = n$$

Taking $n = 5$ we get,

$$\binom{5}{0} = 1, \binom{5}{1} = 5, \binom{5}{2} = \frac{5 \times 4}{1 \times 2} = 10$$

$$\binom{5}{3} = \frac{5 \times 4 \times 3}{1 \times 2 \times 3} = 10, \quad \binom{5}{4} = \frac{5 \times 4 \times 3 \times 2}{1 \times 2 \times 3 \times 4} = 5$$

$$\text{and } \binom{5}{5} = \frac{5 \times 4 \times 3 \times 2 \times 1}{1 \times 2 \times 3 \times 4 \times 5} = 1$$

Therefore, in case of $\binom{5}{3}$ it can be said, $\binom{5}{3} = \frac{5 \times (5-1) \times (5-2)}{1 \times 2 \times 3}$ and

$$\binom{6}{4} = \frac{6 \times (6-1) \times (6-2) \times (6-3)}{1 \times 2 \times 3 \times 4}$$

Generally, we can write,

$$\binom{n}{0} = 1, \quad \binom{n}{n} = 1$$

$$\binom{n}{r} = \frac{n \times (n-1) \times (n-2) \cdots (n-r+1)}{1 \times 2 \times 3 \times 4 \cdots r}$$

Using appropriate sign,

$$\begin{aligned} (1+y)^4 &= \binom{4}{0}y^0 + \binom{4}{1}y^1 + \binom{4}{2}y^2 + \binom{4}{3}y^3 + \binom{4}{4}y^4 \\ &= 1 + 4y + 6y^2 + 4y^3 + y^4 \end{aligned}$$

$$\begin{aligned} (1+y)^5 &= \binom{5}{0}y^0 + \binom{5}{1}y^1 + \binom{5}{2}y^2 + \binom{5}{3}y^3 + \binom{5}{4}y^4 + \binom{5}{5}y^5 \\ &= 1 + 5y + 10y^2 + 10y^3 + 5y^4 + y^5 \end{aligned}$$

and expansion of $(1+y)^n$

$$\begin{aligned} (1+y)^n &= \binom{n}{0}y^0 + \binom{n}{1}y^1 + \binom{n}{2}y^2 + \binom{n}{3}y^3 + \cdots + \binom{n}{n}y^n \\ &= 1 \cdot y^0 + ny^1 + \frac{n(n-1)}{1 \cdot 2}y^2 + \frac{n(n-1)(n-2)}{1 \cdot 2 \cdot 3}y^3 + \cdots + 1 \cdot y^n \end{aligned}$$

$$\therefore (1+y)^n = 1 + ny + \frac{n(n-1)}{1 \cdot 2}y^2 + \frac{n(n-1)(n-2)}{1 \cdot 2 \cdot 3}y^3 + \cdots + y^n$$

Example 1. Expand $(1+3x)^5$

Solution: With the help of Pascal's Triangle

$$\begin{array}{cccccc}
 & & & & & 1 \\
 & & & & & 1 & 1 \\
 & & & & 1 & 2 & 1 \\
 & & & 1 & 3 & 3 & 1 \\
 & & 1 & 4 & 6 & 4 & 1 \\
 1 & 5 & 10 & 10 & 5 & 1
 \end{array}$$

$$\begin{aligned}
 (1 + 3x)^5 &= 1 + 5(3x) + 10(3x)^2 + 10(3x)^3 + 5(3x)^4 + 1(3x)^5 \\
 &= 1 + 15x + 90x^2 + 270x^3 + 405x^4 + 243x^5
 \end{aligned}$$

Using binomial theorem-

$$\begin{aligned}
 (1 + 3x)^5 &= \binom{5}{0}(3x)^0 + \binom{5}{1}(3x)^1 + \binom{5}{2}(3x)^2 + \binom{5}{3}(3x)^3 + \binom{5}{4}(3x)^4 \\
 &+ \binom{5}{5}(3x)^5 \\
 , (1 + 3x)^5 &= 1 + \frac{5}{1}(3x) + \frac{5 \cdot 4}{1 \cdot 2}(3x)^2 + \frac{5 \cdot 4 \cdot 3}{1 \cdot 2 \cdot 3}(3x)^3 + \frac{5 \cdot 4 \cdot 3 \cdot 2}{1 \cdot 2 \cdot 3 \cdot 4}(3x)^4 + 1 \cdot (3x)^5 \\
 &= 1 + 15x + 90x^2 + 270x^3 + 405x^4 + 243x^5
 \end{aligned}$$

Example 2. Expand $(1 - 3x)^5$

Solution: Using Pascal's Triangle

$$\begin{array}{cccccc}
 & & & & & 1 \\
 & & & & & 1 & 1 \\
 & & & & 1 & 2 & 1 \\
 & & & 1 & 3 & 3 & 1 \\
 & & 1 & 4 & 6 & 4 & 1 \\
 1 & 5 & 10 & 10 & 5 & 1
 \end{array}$$

$$\begin{aligned}
 (1 - 3x)^5 &= 1 + 5(-3x) + 10(-3x)^2 + 10(-3x)^3 + 5(-3x)^4 + 1(-3x)^5 \\
 &= 1 - 15x + 90x^2 - 270x^3 + 405x^4 - 243x^5
 \end{aligned}$$

Using binomial theorem-

$$\begin{aligned}
 (1 - 3x)^5 &= \binom{5}{0}(-3x)^0 + \binom{5}{1}(-3x)^1 + \binom{5}{2}(-3x)^2 + \binom{5}{3}(-3x)^3 + \binom{5}{4}(-3x)^4 \\
 &+ \binom{5}{5}(-3x)^5 \\
 &= 1 + \frac{5}{1}(-3x) + \frac{5 \cdot 4}{1 \cdot 2}(-3x)^2 + \frac{5 \cdot 4 \cdot 3}{1 \cdot 2 \cdot 3}(-3x)^3 + \frac{5 \cdot 4 \cdot 3 \cdot 2}{1 \cdot 2 \cdot 3 \cdot 4}(-3x)^4 + 1 \cdot (-3x)^5
 \end{aligned}$$

Forma-31, Higher Mathe, Class-9-10

$$= 1 - 15x + 90x^2 - 270x^3 + 405x^4 - 243x^5$$

Remark: From the expansion of $(1 + 3x)^5$ and $(1 - 3x)^5$, we see that both the expansions are same. By changing only the signs of coefficients we get one from the other, i.e. $+$, $-$, $+$, \dots

Activity: Expand $(1 + 2x^2)^7$ and $(1 - 2x^2)^7$

Example 3. Expand up to the fifth term of $(1 + \frac{2}{x})^8$

Solution:

Using Binomial expansion, expand up to the fifth term of $(1 + \frac{2}{x})^8$ as follows:

$$(1 + \frac{2}{x})^8 = \binom{8}{0}(\frac{2}{x})^0 + \binom{8}{1}(\frac{2}{x})^1 + \binom{8}{2}(\frac{2}{x})^2 + \binom{8}{3}(\frac{2}{x})^3 + \binom{8}{4}(\frac{2}{x})^4$$

$$= 1 \cdot 1 + \frac{8}{1} \cdot \frac{2}{x} + \frac{8 \cdot 7}{1 \cdot 2} \cdot \frac{4}{x^2} + \frac{8 \cdot 7 \cdot 6}{1 \cdot 2 \cdot 3} \cdot \frac{8}{x^3} + \frac{8 \cdot 7 \cdot 6 \cdot 5}{1 \cdot 2 \cdot 3 \cdot 4} \cdot \frac{16}{x^4}$$

$$= 1 + \frac{16}{x} + \frac{112}{x^2} + \frac{448}{x^3} + \frac{1120}{x^4}$$

$$\therefore (1 + \frac{2}{x})^8 = 1 + \frac{16}{x} + \frac{112}{x^2} + \frac{448}{x^3} + \frac{1120}{x^4} \text{ [Expansion up to the fifth term]}$$

[Try yourself using Pascal's Triangle]

Example 4. Find the coefficients of x^3 and x^6 in the expansion of $(1 - \frac{x^2}{4})^8$

Solution: By binomial expansion, we get

$$(1 - \frac{x^2}{4})^8 = \binom{8}{0}(-\frac{x^2}{4})^0 + \binom{8}{1}(-\frac{x^2}{4})^1 + \binom{8}{2}(-\frac{x^2}{4})^2 + \binom{8}{3}(-\frac{x^2}{4})^3 + \binom{8}{4}(-\frac{x^2}{4})^4 + \dots$$

$$= 1 \cdot 1 + \frac{8}{1} \cdot (-\frac{x^2}{4}) + \frac{8 \cdot 7}{1 \cdot 2} \cdot (\frac{x^4}{16}) + \frac{8 \cdot 7 \cdot 6}{1 \cdot 2 \cdot 3} \cdot (-\frac{x^6}{64}) + \frac{8 \cdot 7 \cdot 6 \cdot 5}{1 \cdot 2 \cdot 3 \cdot 4} \cdot (\frac{x^8}{256}) + \dots$$

$$= 1 - 2x^2 + \frac{7}{4}x^4 - \frac{7}{8}x^6 + \dots$$

Here we see that in the expansion of $(1 - \frac{x^2}{4})^8$ the term containing x^3 is absent. So coefficient of x^3 is 0 and coefficient of x^6 is $-\frac{7}{8}$.

\therefore coefficient of x^3 is 0 and coefficient x^6 is $-\frac{7}{8}$.

Activity: Verify using Pascal's Triangle.

Exercise 10.1

1. Find the expansion of $(1 + y)^5$ by the help of pascal's triangle or binomial theorem. With the help of the above expansion find 1) $(1 - y)^5$ and 2) $(1 + 2x)^5$.
2. According to the ascending power of x , expand the following up to first four terms 1) $(1 + 4x)^6$ and 2) $(1 - 3x)^7$
3. Expand $(1 + x^2)^8$ upto first four terms. Find the value of $(1.01)^8$ by using the result.
4. According to the ascending power of x , expand the following upto first three terms
 - 1) $(1 - 2x)^5$ 2) $(1 + 3x)^9$
5. Find the following expansion upto first four terms [using Pascal's Triangle or binomial theorem]
 - 1) $(1 - 2x^2)^7$ 2) $\left(1 + \frac{2}{x}\right)^4$ 3) $\left(1 - \frac{1}{2x}\right)^7$
6. Expand 1) $(1 - x)^6$ and 2) $(1 + 2x)^6$ up to x^3

Binomial expansion of $(x + y)^n$

We have so far discussed the expansion of $(1 + y)^n$, now we shall discuss the general form of binomial expansion $(x + y)^n$ where n is a positive integer. Generally the expansion of $(x + y)^n$ is known as binomial theorem.

We know,

$$(1 + y)^n = 1 + \binom{n}{1}y + \binom{n}{2}y^2 + \binom{n}{3}y^3 + \cdots + \binom{n}{r}y^r + \cdots + \binom{n}{n}y^n$$

Now, $(x + y)^n = \left[x\left(1 + \frac{y}{x}\right)\right]^n = x^n\left(1 + \frac{y}{x}\right)^n$

$$\begin{aligned} \therefore (x+y)^n &= x^n \left[1 + \binom{n}{1} \left(\frac{y}{x}\right) + \binom{n}{2} \left(\frac{y}{x}\right)^2 + \binom{n}{3} \left(\frac{y}{x}\right)^3 + \dots + \binom{n}{n} \left(\frac{y}{x}\right)^n \right] \\ \therefore (x+y)^n &= x^n \left[1 + \binom{n}{1} \frac{y}{x} + \binom{n}{2} \frac{y^2}{x^2} + \binom{n}{3} \frac{y^3}{x^3} + \dots + \frac{y^n}{x^n} \right] \quad \left[\because \binom{n}{n} = 1 \right] \\ &= x^n + \binom{n}{1} \left(x^n \cdot \frac{y}{x}\right) + \binom{n}{2} \left(x^n \cdot \frac{y^2}{x^2}\right) + \binom{n}{3} \left(x^n \cdot \frac{y^3}{x^3}\right) + \dots + x^n \cdot \frac{y^n}{x^n} \end{aligned}$$

$$(x+y)^n = x^n + \binom{n}{1} x^{n-1}y + \binom{n}{2} x^{n-2}y^2 + \binom{n}{3} x^{n-3}y^3 + \dots + y^n$$

This is the general form of binomial theorem. Observe that it is similar to $(1+y)^n$. Here, power of x is added from n to 0. We also observe that addition of power of x and y in every term is equal to the power of binomial expansion. Powers of x from initial term to the last term is decreasing from n to 0 and conversely the powers of y is increasing from 0 to n .

Example 5. Expand $(x+y)^5$ and from that expansion find $(3+2x)^5$.

Solution: $(x+y)^5 = x^5 + \binom{5}{1} x^4y + \binom{5}{2} x^3y^2 + \binom{5}{3} x^2y^3 + \binom{5}{4} xy^4 + y^5$

$$\begin{aligned} &= x^5 + 5x^4y + \frac{5 \cdot 4}{1 \cdot 2} x^3y^2 + \frac{5 \cdot 4 \cdot 3}{1 \cdot 2 \cdot 3} x^2y^3 + \frac{5 \cdot 4 \cdot 3 \cdot 2}{1 \cdot 2 \cdot 3 \cdot 4} xy^4 + y^5 \\ &= x^5 + 5x^4y + 10x^3y^2 + 10x^2y^3 + 5xy^4 + y^5 \end{aligned}$$

\therefore Required expansion $(x+y)^5 = x^5 + 5x^4y + 10x^3y^2 + 10x^2y^3 + 5xy^4 + y^5$

Now, putting $x = 3$ and $y = 2x$

$$\begin{aligned} (3+2x)^5 &= 3^5 + 5 \cdot 3^4(2x) + 10 \cdot 3^3(2x)^2 + 10 \cdot 3^2(2x)^3 + 5 \cdot 3(2x)^4 + (2x)^5 \\ &= 243 + 810x + 1080x^2 + 720x^3 + 240x^4 + 32x^5 \end{aligned}$$

$\therefore (3+2x)^5 = 243 + 810x + 1080x^2 + 720x^3 + 240x^4 + 32x^5$

Example 6. Expand $\left(x + \frac{1}{x^2}\right)^6$ upto fourth term in decending power of x and identify the term which is free of x .

Solution: We get by binomial theorem,

$$\left(x + \frac{1}{x^2}\right)^6 = x^6 + \binom{6}{1} x^5 \left(\frac{1}{x^2}\right) + \binom{6}{2} x^4 \left(\frac{1}{x^2}\right)^2 + \binom{6}{3} x^3 \left(\frac{1}{x^2}\right)^3 + \dots$$

$$= x^6 + 6x^3 + \frac{6 \cdot 5}{1 \cdot 2} x^4 \frac{1}{x^4} + \frac{6 \cdot 5 \cdot 4}{1 \cdot 2 \cdot 3} x^3 \frac{1}{x^6} + \dots$$

$$= x^6 + 6x^3 + 15 + 20 \frac{1}{x^3} + \dots$$

\therefore Required expansion is $x^6 + 6x^3 + 15 + 20 \frac{1}{x^3} + \dots$ and x -free term 15

Example 7. Expand $\left(2 - \frac{x}{2}\right)^7$ upto first four term in ascending power of x . Find also $(1.995)^7$ upto four decimal places.

Solution: $\left(2 - \frac{x}{2}\right)^7 = 2^7 + \binom{7}{1} 2^6 \left(-\frac{x}{2}\right) + \binom{7}{2} 2^5 \left(-\frac{x}{2}\right)^2 + \binom{7}{3} 2^4 \left(-\frac{x}{2}\right)^3 + \dots$

$$= 128 + 7 \cdot 64 \left(-\frac{x}{2}\right) + \frac{7 \cdot 6}{1 \cdot 2} \cdot 32 \left(\frac{x^2}{4}\right) + \frac{7 \cdot 6 \cdot 5}{1 \cdot 2 \cdot 3} \cdot 16 \left(-\frac{x^3}{8}\right) + \dots$$

$$\therefore \left(2 - \frac{x}{2}\right)^7 = 128 - 224x + 168x^2 - 70x^3 + \dots$$

\therefore Required expansion is $\left(2 - \frac{x}{2}\right)^7 = 128 - 224x + 168x^2 - 70x^3 + \dots$

Now, $2 - \frac{x}{2} = 1.995$ or, $\frac{x}{2} = 2 - 1.995$ Hence $x = 0.01$

Now, putting $x = 0.01$ we get

$$\left(2 - \frac{0.01}{2}\right)^7 = 128 - 224 \times (0.01) + 168 \times (0.01)^2 - 70 \times (0.01)^3 + \dots$$

or, $(1.995)^7 = 125.7767$ (up to four decimal places)

Required Value $(1.995)^7 = 125.7767$

Finding the value of $n!$ and ${}^n C_r$

Observe the following examples:

$$2 = 2 \cdot 1, 6 = 3 \cdot 2 \cdot 1, 24 = 4 \cdot 3 \cdot 2 \cdot 1, 120 = 5 \cdot 4 \cdot 3 \cdot 2 \cdot 1, \dots$$

We can briefly express the product on right side by a symbol.

$$2 = 2 \cdot 1 = 2!, 6 = 3 \cdot 2 \cdot 1 = 3!, 24 = 4 \cdot 3 \cdot 2 \cdot 1 = 4!, 120 = 5 \cdot 4 \cdot 3 \cdot 2 \cdot 1 = 5!, \dots$$

Now we observe

$$4! = 4 \cdot 3 \cdot 2 \cdot 1 = 4 \cdot (4 - 1) \cdot (4 - 2) \cdot (4 - 3)$$

$$5! = 5 \cdot 4 \cdot 3 \cdot 2 \cdot 1 = 5 \cdot (5 - 1) \cdot (5 - 2) \cdot (5 - 3) \cdot (5 - 4)$$

Therefore, generally we can write, $n! = n(n-1)(n-2)(n-3)\cdots 3 \cdot 2 \cdot 1$ and $n!$ is called Factorial n . Similarly, $3!$ is called factorial of 3, $4!$ is called factorial of 4.

Again we observe:

$$\binom{5}{3} = \frac{5 \cdot 4 \cdot 3}{1 \cdot 2 \cdot 3} = \frac{5 \cdot 4 \cdot 3 \cdot 2 \cdot 1}{(1 \cdot 2 \cdot 3) \cdot (2 \cdot 1)} = \frac{5!}{3! \times 2!} = \frac{5!}{3! \times (5-3)!}$$

$$\binom{7}{4} = \frac{7 \cdot 6 \cdot 5 \cdot 4}{1 \cdot 2 \cdot 3 \cdot 4} = \frac{7 \cdot 6 \cdot 5 \cdot 4 \cdot 3 \cdot 2 \cdot 1}{(1 \cdot 2 \cdot 3 \cdot 4) \cdot (3 \cdot 2 \cdot 1)} = \frac{7!}{4! \times 3!} = \frac{7!}{4! \times (7-4)!}$$

$$\therefore \text{Generally we can say } \binom{n}{r} = \frac{n!}{r!(n-r)!}$$

Factorials of the right side can be expressed by this symbol,

$$\binom{n}{r} = \frac{n!}{r!(n-r)!} = {}^n C_r$$

$$\therefore \binom{7}{4} = \frac{7!}{4!(7-4)!} = {}^7 C_4 \text{ and } \binom{5}{3} = \frac{5!}{3!(5-3)!} = {}^5 C_3$$

Therefore, $\binom{n}{r} = {}^n C_r$, i.e., $\binom{n}{r}$ are ${}^n C_r$ equal.

$$\therefore \binom{n}{1} = {}^n C_1, \binom{n}{2} = {}^n C_2, \binom{n}{3} = {}^n C_3, \dots, \binom{n}{n} = {}^n C_n$$

$$\text{We know, } \binom{n}{n} = {}^n C_n = \frac{n!}{n!(n-n)!} = \frac{n!}{n!(0)!} = \frac{1}{0!}$$

$$\therefore 1 = \frac{1}{0!}, \text{ i.e. } 0! = 1$$

Remember,

$$n! = n(n-1)(n-2)\cdots 3 \cdot 2 \cdot 1$$

$$\binom{n}{r} = {}^n C_r, \quad {}^n C_n = 1$$

$$\binom{n}{r} = {}^n C_r = \frac{n!}{r!(n-r)!}, \quad \binom{n}{0} = {}^n C_0 = 1$$

$$\binom{n}{n} = {}^n C_n = 1, \quad 0! = 1$$

Now we use ${}^n C_r$ instead of $\binom{n}{r}$ in binomial theorem.

$$(1 + y)^n = 1 + {}^nC_1y + {}^nC_2y^2 + {}^nC_3y^3 + \cdots + {}^nC_ry^r + \cdots + {}^nC_ny^n$$

$$\text{or, } (1 + y)^n = 1 + ny + \frac{n(n-1)}{2!}y^2 + \frac{n(n-1)(n-2)}{3!}y^3 + \cdots + y^n$$

$$(1 + y)^n = 1 + ny + \frac{n(n-1)}{1 \cdot 2}y^2 + \frac{n(n-1)(n-2)}{1 \cdot 2 \cdot 3}y^3 + \cdots + y^n$$

and similarly,

$$(x + y)^n = x^n + {}^nC_1x^{n-1}y + {}^nC_2x^{n-2}y^2 + {}^nC_3x^{n-3}y^3 + \cdots + {}^nC_rx^{n-r}y^r + \cdots + {}^nC_ny^n$$

$$\text{or, } (x + y)^n = x^n + nx^{n-1}y + \frac{n(n-1)}{2!}x^{n-2}y^2 + \frac{n(n-1)(n-2)}{3!}x^{n-3}y^3 + \cdots + y^n$$

$$(x + y)^n = x^n + nx^{n-1}y + \frac{n(n-1)}{1 \cdot 2}x^{n-2}y^2 + \frac{n(n-1)(n-2)}{1 \cdot 2 \cdot 3}x^{n-3}y^3 + \cdots + y^n$$

Observe : For positive integer n

the general term or $(r + 1)$ -th term of binomial expansion of $(1 + y)^n$ is $T_{r+1} = \binom{n}{r}y^r$ or, ${}^nC_ry^r$

Here, $\binom{n}{r}$ or nC_r is the coefficient of binomial expansion

$$(x + y)^n = x^n + {}^nC_1x^{n-1}y + {}^nC_2x^{n-2}y^2 + {}^nC_3x^{n-3}y^3 + \cdots + {}^nC_ny^n$$

$$\text{or } (x + y)^n = x^n + nx^{n-1}y + \frac{n(n-1)}{2!}x^{n-2}y^2 + \frac{n(n-1)(n-2)}{3!}x^{n-3}y^3 + \cdots + y^n$$

General term or $(r + 1)$ th term $T_{r+1} = \binom{n}{r}x^{n-r}y^r$ or ${}^nC_rx^{n-r}y^r$ where $\binom{n}{r}$ or nC_r is the coefficient of binomial expansion.

Example 8. Expand $\left(x - \frac{1}{x^2}\right)^5$

Solution: By binomial theorem

$$\begin{aligned} \left(x - \frac{1}{x^2}\right)^5 &= x^5 + {}^5C_1x^{5-1}\left(-\frac{1}{x^2}\right) + {}^5C_2x^{5-2}\left(-\frac{1}{x^2}\right)^2 + {}^5C_3x^{5-3}\left(-\frac{1}{x^2}\right)^3 \\ &\quad + {}^5C_4x^{5-4}\left(-\frac{1}{x^2}\right)^4 + \left(-\frac{1}{x^2}\right)^5 \end{aligned}$$

$$\begin{aligned}
&= x^5 - 5x^4 \cdot \frac{1}{x^2} + \frac{5 \cdot 4}{1 \cdot 2} x^3 \frac{1}{x^4} - \frac{5 \cdot 4 \cdot 3}{1 \cdot 2 \cdot 3} x^2 \frac{1}{x^6} + \frac{5 \cdot 4 \cdot 3 \cdot 2}{1 \cdot 2 \cdot 3 \cdot 4} x \frac{1}{x^8} - \frac{1}{x^{10}} \\
&= x^5 - 5x^2 + \frac{10}{x} - \frac{10}{x^4} + \frac{5}{x^7} - \frac{1}{x^{10}}
\end{aligned}$$

Example 9. Expand $\left(2x^2 - \frac{1}{x^2}\right)^8$ up to four terms.

Solution: Using binomial theorem, $\left(2x^2 - \frac{1}{x^2}\right)^8$

$$\begin{aligned}
&= (2x^2)^8 + {}^8C_1(2x^2)^7 \left(-\frac{1}{x^2}\right) + {}^8C_2(2x^2)^6 \left(-\frac{1}{x^2}\right)^2 + {}^8C_3(2x^2)^5 \left(-\frac{1}{x^2}\right)^3 + \dots \\
&= 2^8 \cdot x^{16} - 8 \cdot 2^7 \cdot x^{14} \cdot \frac{1}{x^2} + \frac{8 \cdot 7}{1 \cdot 2} \cdot 2^6 \cdot x^{12} \cdot \frac{1}{x^4} - \frac{8 \cdot 7 \cdot 6}{1 \cdot 2 \cdot 3} \cdot 2^5 \cdot x^{10} \cdot \frac{1}{x^6} + \dots \\
&= 256x^{16} - 1024x^{12} + 1792x^8 - 1792x^4 + \dots
\end{aligned}$$

Example 10. In the expansion of $\left(k - \frac{x}{3}\right)^7$, the coefficient of k^3 is 560

- 1) if $k = 1$, expand up to fourth term.
- 2) determine x
- 3) if in the expansion, coefficient of x^3 is 15 times the coefficient of x^5 , then determine the value of k .

Solution:

- 1) if $k = 1$, the algebraic term is $\left(1 - \frac{x}{3}\right)^7$

Using binomial theorem

$$\begin{aligned}
\left(1 - \frac{x}{3}\right)^7 &= {}^7C_0 \left(-\frac{x}{3}\right)^0 + {}^7C_1 \left(-\frac{x}{3}\right)^1 + {}^7C_2 \left(-\frac{x}{3}\right)^2 + {}^7C_3 \left(-\frac{x}{3}\right)^3 + \dots \\
&= 1 - 7 \cdot \frac{x}{3} + \frac{7 \cdot 6}{1 \cdot 2} \cdot \frac{x^2}{9} - \frac{7 \cdot 6 \cdot 5}{1 \cdot 2 \cdot 3} \cdot \frac{x^3}{27} + \dots \\
&= 1 - \frac{7x}{3} + \frac{7x^2}{3} - \frac{35x^3}{27} + \dots
\end{aligned}$$

- 2) Using binomial theorem,

$$\begin{aligned}
\left(k - \frac{x}{3}\right)^7 &= k^7 + {}^7C_1 k^6 \left(-\frac{x}{3}\right) + {}^7C_2 k^5 \left(-\frac{x}{3}\right)^2 + {}^7C_3 k^4 \left(-\frac{x}{3}\right)^3 \\
&\quad + {}^7C_4 k^3 \left(-\frac{x}{3}\right)^4 + {}^7C_5 k^2 \left(-\frac{x}{3}\right)^5 + \dots
\end{aligned}$$

$$\begin{aligned}
&= k^7 - 7k^6 \cdot \frac{x}{3} + \frac{7 \cdot 6}{1 \cdot 2} k^5 \cdot \frac{x^2}{9} - \frac{7 \cdot 6 \cdot 5}{1 \cdot 2 \cdot 3} k^4 \cdot \frac{x^3}{27} \\
&\quad + \frac{7 \cdot 6 \cdot 5 \cdot 4}{1 \cdot 2 \cdot 3 \cdot 4} k^3 \cdot \frac{x^4}{81} - \frac{7 \cdot 6 \cdot 5 \cdot 4 \cdot 3}{1 \cdot 2 \cdot 3 \cdot 4 \cdot 5} k^2 \cdot \frac{x^5}{243} + \dots \\
&= k^7 - \frac{7x}{3} \cdot k^6 + \frac{7x^2}{3} \cdot k^5 - \frac{35x^3}{27} \cdot k^4 + \frac{35x^4}{81} \cdot k^3 - \frac{7x^5}{81} \cdot k^2 + \dots
\end{aligned}$$

Here, coefficient of k^3 is $\frac{35x^4}{81}$

According to the question, $\frac{35x^4}{81} = 560$ or, $x^4 = \frac{560 \times 81}{35}$ or, $x^4 = 1296$

$\therefore x = 6$

3) Getting from the result of expansion of $\left(k - \frac{x}{3}\right)^7$ from just above,

$$\left(k - \frac{x}{3}\right)^7 = k^7 - \frac{7x}{3} \cdot k^6 + \frac{7x^2}{3} \cdot k^5 - \frac{35x^3}{27} \cdot k^4 + \frac{35x^4}{81} \cdot k^3 - \frac{7x^5}{81} \cdot k^2 + \dots$$

Coefficient of x^3 is $\frac{-35k^4}{27}$ and coefficient of x^5 is $\frac{-7k^2}{81}$

Accordingly, $\frac{-35k^4}{27} = -\frac{7k^2}{81} \times 15$ or, $\frac{k^4}{k^2} = \frac{27 \times 7 \times 15}{35 \times 81}$ or, $k^2 = 1$

$\therefore k = 1$

Exercise 10.2

1. In the expansion of $(1 + 2x + x^2)^3$ -

(i) Number of terms is 4 (ii) Second term is $6x$ (iii) Last term is x^6

Which one is correct?

1) *i, ii* 2) *i, iii* 3) *ii, iii* 4) *i, ii and iii*

$\left(x + \frac{1}{x}\right)^n$, where n is even. From this information answer the questions 2 and 3.

2. If $(r + 1)$ th term is free of x what is the value of r ?

1) 0 2) $\frac{n}{2}$ 3) n 4) $2n$

3. If $n = 4$, then which one is the fourth term?

- 1) 4 2) $4x$ 3) $\frac{4}{x}$ 4) $\frac{4}{x^2}$
4. The coefficients of expansion of $(x + y)^5$ are:
 1) 5, 10, 10, 5 2) 1, 5, 10, 10, 5, 1
 3) 10, 5, 5, 10 4) 1, 2, 3, 3, 2, 1
5. In the expansion of $(1 - x) \left(1 + \frac{x}{2}\right)^8$, the coefficient of x is-
 1) -1 2) $\frac{1}{2}$ 3) 3 4) $-\frac{1}{2}$
6. What is the x -free term in the expansion of $\left(x^2 + \frac{1}{x^2}\right)^4$?
 1) 4 2) 6 3) 8 4) 0
7. Ordering the coefficients of the expansion of $(x + y)^4$ we get,
 1)
$$\begin{array}{ccccccc} & & & 4 & & & \\ & & 1 & 4 & 1 & & \\ & 1 & 5 & 5 & 1 & & \\ 1 & 6 & 10 & 6 & 1 & & \end{array}$$

 2)
$$\begin{array}{ccccccc} & & & 1 & & & \\ & & 1 & 2 & 1 & & \\ & 1 & 3 & 3 & 1 & & \\ 1 & 4 & 6 & 4 & 1 & & \\ & & & 6 & & & \\ & & 6 & 12 & 6 & & \\ 6 & 18 & 18 & 6 & & & \\ 6 & 24 & 36 & 24 & 6 & & \end{array}$$

 3)
$$\begin{array}{ccccccc} & & & 2 & 3 & 2 & \\ & 1 & 5 & 5 & 2 & & \\ 2 & 7 & 10 & 7 & 2 & & \end{array}$$

 4)
$$\begin{array}{ccccccc} & & & 6 & 12 & 6 & \\ & 6 & 18 & 18 & 6 & & \\ 6 & 24 & 36 & 24 & 6 & & \end{array}$$
8. Expand each of these:
 1) $(2 + x^2)^5$ 2) $\left(2 - \frac{1}{2x}\right)^6$
9. Determine the first four terms of these expansions:
 1) $(2 + 3x)^6$ 2) $\left(4 - \frac{1}{2x}\right)^5$
10. If $\left(p - \frac{1}{2}x\right)^6 = r - 96x + sx^2 + \dots$, determine p , r and s .
11. Determine the coefficient of x^3 in the expansion of $\left(1 + \frac{x}{2}\right)^8$.
12. Expand $\left(2 + \frac{x}{4}\right)^6$ up to x^3 in ascending power of x . Find the approximate value of $(1.9975)^6$ up to four decimal places.
13. Using binomial theorem, find the value of $(1.99)^5$ up to four decimal places.
14. In the expansion of $\left(1 + \frac{x}{4}\right)^n$, coefficients of 3rd term is the double of the coefficient of the 4th term. Find the value of n . Also, determine the number of terms and middle term of the expansion.

15. 1) In the expansion of $\left(2k - \frac{x}{2}\right)^5$ coefficient of k^3 is 720, find the value of x .
- 2) In the expansion of $\left(x^2 + \frac{k}{x}\right)^6$ coefficient of x^3 is 160, find the value of k .
16. $A = (1 + x)^7$ and $B = (1 - x)^8$
- 1) Determine the expansion of A using Pascal's Triangle.
- 2) Expand B upto four terms. Use the result to find the value of $(0.99)^8$ upto four decimal places.
- 3) Determine the coefficient of x^7 in the expansion of AB .
17. $(A + Bx)^n$ is an algebraic expression.
- 1) If $A = 1$, $B = 2$ and $n = 5$, determine the expansion of the expression using Pascal's Triangle.
- 2) If $B = 3$ and $n = 7$, in the expansion of the expression, coefficient of x^4 is 22680. Determine A .
- 3) If $A = 2$ and $B = 1$, then the coefficients of 5th and 6th terms of the expansion are same. Determine the value of n
18. If a_1, a_2, a_3, a_4 are four consecutive terms in the expansion of $(1 + x)^n$, then prove that $\frac{a_1}{a_1 + a_2} + \frac{a_3}{a_3 + a_4} = \frac{2a_2}{a_2 + a_3}$.
19. Which one is bigger? $99^{50} + 100^{50}$ or 101^{50} ?

Chapter 11

Coordinate Geometry

The portion of geometry where the algebraic expressions of points, straight lines and curved lines are studied is known as the Coordinate Geometry. This portion of geometry is also known as the Analytic Geometry. With the plotting of points on the plane, the straight lines or the curved lines or the figures of the geometric regions made by them such as the triangles, the quadrilaterals, the circles etc. are expressed. The system of plotting of points on the plane was initiated by a French mathematician named Rene Descartes (known as Descartes). The coordinate system of geometry initiated by Descartes is called the Cartesian coordinate system after his name. The coordinate geometry and the analytical geometry are mainly based on Cartesian coordinate system. So, Descartes is called the initiator of the analytical geometry.

In the first part of this chapter, the tricks of determining the distance between two points will be discussed through developing the concept of the Cartesian coordinate system among the students. In the second part, the method of determining the area of any triangle and quadrilateral created by straight lines will be discussed. On the other hand, in the third part, the tricks of determining the slope of a straight line and the simplification of the joining straight line between the two points will be explained. No figure or equation associated with the curved line will be discussed here. In higher classes, it will be discussed elaborately.

After completing this chapter, the students will be able to –

- ▶ explain the rectangular Cartesian coordinate system;
- ▶ find the distance between two points;
- ▶ explain the concept of slope (gradient) of a straight line;
- ▶ find the equation of a straight line;
- ▶ determine the area of a triangle using coordinate system;

- ▶ find areas of triangular and quadrangular regions by measuring the lengths of the sides;
- ▶ construct the geometric figures of the triangles and quadrilaterals by plotting of points;
- ▶ present an equation of a straight line by plotting points.

Rectangular Cartesian Coordinates

We have been acquainted with the concept of plane in previous class. The surface of a table, the floor of a room, the surface of a book, even the paper on which we write down, each of them is a plane. The surface of a football or the surface of a bottle are curved planes. In this part, the tricks of determining the proper position of any point lying on the plane will be discussed. For determining the proper position of any definite point, it is necessary to know the distance of the definite point from the straight line bisectors constructed on the plane. It is said as a reason that only a point can lie at any definite distance from two straight line bisectors.

If two such straight lines XOX' and YOY' are drawn that intersect each other at a right angle on any plane, XOX' is called the x -axis, YOY' is called the y -axis and the intersecting point ' O ' is called the origin.

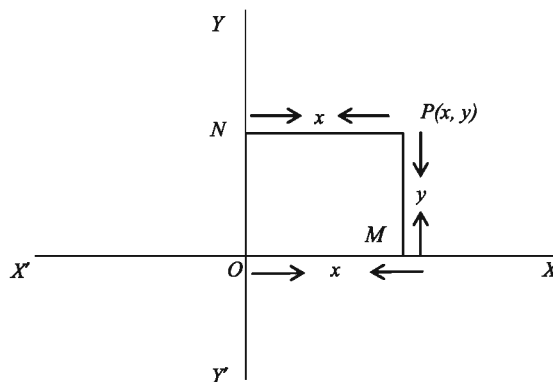

Now, let P be any point on the plane of the two axis. From point P , on XOX' i.e., the x -axis and on YOY' i.e., the y -axis, the perpendiculars are respectively PM and PN . Then the distance of point P from the y -axis = $NP = OM = x$ is called the abscissa of P or x -coordinate. Again, the distance of P from the x -axis = $MP = ON = y$ is called the ordinate of P or y -coordinate. The abscissa and

the Ordinate are jointly called the Coordinate. So, in the figure, the coordinate of P means the perpendicular distance of P from the y -axis and the x -axis and by denoting them as x and y , the coordinate of P is expressed by the symbol $P(x, y)$.

The coordinate index (x, y) means an ordered pair whose first element indicates the abscissa and the second element indicates the ordinate. So, if $x \neq y$, by (x, y) and (y, x) , two different points are meant. Therefore, the coordinate of any point depending on two axis intersecting each other at the right angle is called the Rectangular Cartesian Coordinates. If the point is placed at the right side of the y -axis, the abscissa will be positive and if it is placed at the left side, the abscissa will be negative. Again, if the point is placed above the x -axis, the ordinate will be positive and if it is placed below, the ordinate will be negative. On the x -axis, the ordinate will be zero and on y -axis, the abscissa will be zero.

So, the positive abscissa and the ordinate of any point will be along OX and OY respectively or parallel to them. Similarly, the negative abscissa or the ordinate will be along OX' and OY' respectively or parallel to them.

By the two axis of the Cartesian coordinates, the plane is divided into XOY , YOX' , $X'OY'$, $Y'OX$ these four parts. Each of them is called a quadrant.

The quadrant XOY is taken as the first and by turns the second, the third and the fourth quadrant remain in anti-clockwise order. According to the sign of the point of the coordinate, the point lies on the different quadrants.

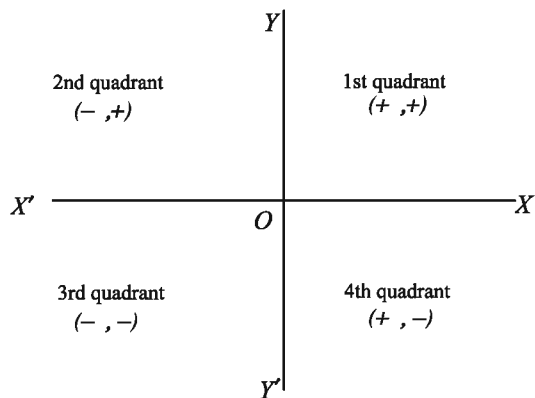

Distance between two points

Let, $P(x_1, y_1)$ and $Q(x_2, y_2)$ be the two different points on a plane. From points P and Q , perpendiculars PM and QN are drawn on x -axis. Again from point P , draw perpendicular PR on QN .

Now the abscissa of point P is $= OM = x_1$ and the ordinate of point P is $= MP = y_1$.

The abscissa of point Q is $= ON = x_2$ and the ordinate NQ is $= y_2$.

From the figure we get,

$$PR = MN = ON - OM = x_2 - x_1$$

$$QR = NQ - NR = NQ - MP = y_2 - y_1$$

As per the construction, PQR is a right angled triangle and PQ is the hypotenuse of the triangle. So, as per the theorem of Pythagoras,

$$PQ^2 = PR^2 + QR^2$$

$$\text{or, } PQ = \pm \sqrt{PR^2 + QR^2}$$

$$\text{or, } PQ = \pm \sqrt{(x_2 - x_1)^2 + (y_2 - y_1)^2}$$

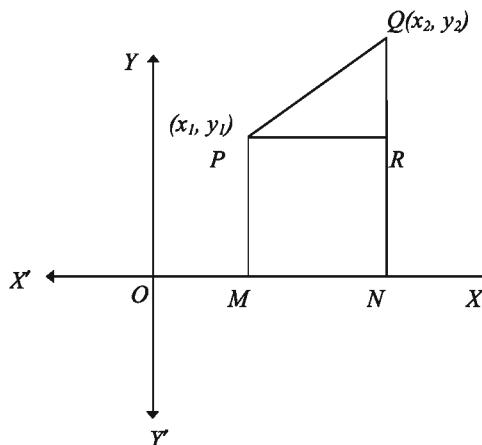

\therefore The distance of P from Q is, $PQ = \sqrt{(x_2 - x_1)^2 + (y_2 - y_1)^2}$

As the distance is always non-negative, the negative value has been avoided.

Again, in the same rule the distance from point Q to P is,

$$QP = \sqrt{(x_1 - x_2)^2 + (y_1 - y_2)^2} = \sqrt{(x_2 - x_1)^2 + (y_2 - y_1)^2}$$

$\therefore PQ = QP$.

The distance from point P to Q or Q to P is equal.

$$\text{Therefore, } PQ = \sqrt{(x_2 - x_1)^2 + (y_2 - y_1)^2} = QP$$

Corollary 1. The distance of any point $P(x, y)$ lying on the plane from the origin $(0, 0)$ is

$$PQ = \sqrt{(x - 0)^2 + (y - 0)^2} = \sqrt{x^2 + y^2}$$

Example 1. Plot the two points $(1, 1)$ and $(2, 2)$ on a plane. Find the distance between them.

Solution: Let $P(1, 1)$ and $Q(2, 2)$ be the given two points. In the figure, the two points have been plotted on the plane xy . The distance between the two points is

$$\begin{aligned} PQ &= \sqrt{(x_2 - x_1)^2 + (y_2 - y_1)^2} \\ &= \sqrt{(2 - 1)^2 + (2 - 1)^2} \\ &= \sqrt{1^2 + 1^2} \\ &= \sqrt{1 + 1} = \sqrt{2} \end{aligned}$$

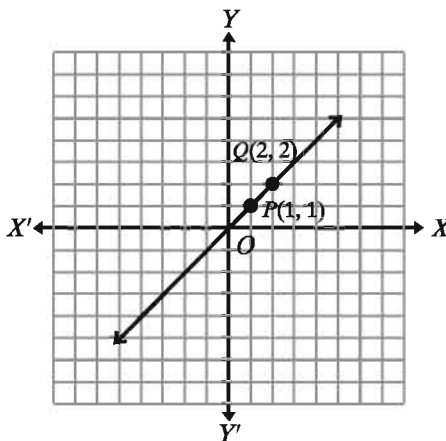

Example 2. Plot the origin $O(0, 0)$ and the other two points $P(3, 0)$ and $Q(0, 3)$ on the plane. Find the distance between each of them. What is the name of the geometric figure after joining these three points? And why?

Solution: The positions of the three points have been shown on the plane.

$$\begin{aligned} \text{Distance } OP &= \sqrt{(3 - 0)^2 + (0 - 0)^2} \\ &= \sqrt{3^2 + 0^2} = \sqrt{3^2} = 3 \text{ unit.} \end{aligned}$$

$$\begin{aligned} \text{Distance } OQ &= \sqrt{(0 - 0)^2 + (3 - 0)^2} \\ &= \sqrt{0^2 + 3^2} = \sqrt{3^2} = 3 \text{ unit.} \end{aligned}$$

$$\begin{aligned} \text{Distance } PQ &= \sqrt{(3 - 0)^2 + (0 - 3)^2} \\ &= \sqrt{9 + 9} = \sqrt{18} = 3\sqrt{2} \text{ unit.} \end{aligned}$$

The name of the geometric figure is the isosceles triangle because the distance between the two sides OP and OQ is equal.

Example 3. The three vertices of a triangle are respectively $A(2, 0)$, $B(7, 0)$ and $C(3, 4)$. Plot these points on the plane and construct the triangle. Find the perimeter of the triangle upto five places of decimals.

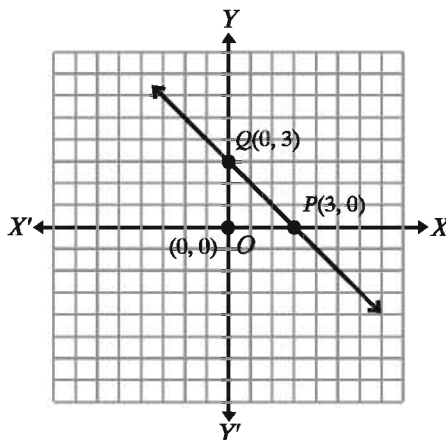

Solution: The position of $A(2, 0)$, $B(7, 0)$ and $C(3, 4)$ on the plane xy has been shown.

Of the triangle ABC ,

The length of the side AB is
 $= \sqrt{(7-2)^2 + (0-0)^2}$
 $= \sqrt{5^2} = 5$ unit

The length of the side BC is
 $= \sqrt{(3-7)^2 + (4-0)^2}$
 $= \sqrt{(-4)^2 + 4^2} = \sqrt{16 + 16} = 4\sqrt{2}$ unit

The length of the side AC is
 $= \sqrt{(3-2)^2 + (4-0)^2}$
 $= \sqrt{1^2 + 4^2} = \sqrt{17}$ unit

\therefore Perimeter of the triangle = $(AB + BC + AC)$ [sum of length of the sides]
 $= (5 + 4\sqrt{2} + \sqrt{17})$ unit = 14.77996 unit (app.)

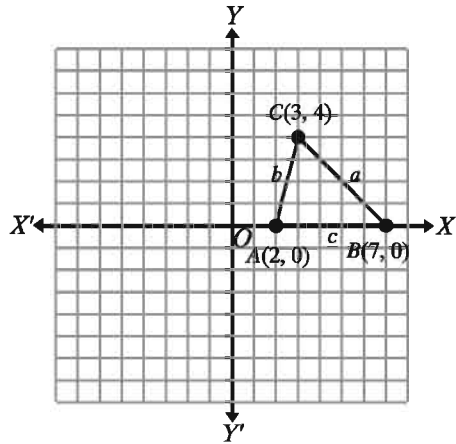

Example 4. Show that the points, $(0, -1)$, $(-2, 3)$, $(6, 7)$ and $(8, 3)$ are the vertices of a rectangle.

Solution: Let, $A(0, -1)$, $B(-2, 3)$, $C(6, 7)$ and $D(8, 3)$ be the given points. Their position on the plane xy has been shown.

The length of the side AB is $= \sqrt{(-2-0)^2 + (3-(-1))^2}$
 $= \sqrt{(-2)^2 + (4)^2} = \sqrt{4 + 16} = 2\sqrt{5}$ unit

The length of the side CD is $= \sqrt{(8-6)^2 + (3-7)^2}$
 $= \sqrt{4 + 16} = 2\sqrt{5}$ unit

\therefore The length of the side AB = The length of the side CD

Again, the length of the side AD is $= \sqrt{(8-0)^2 + (3-(-1))^2}$
 $= \sqrt{8^2 + 4^2} = \sqrt{80} = 4\sqrt{5}$ unit

The length of the side BC is $= \sqrt{(6-(-2))^2 + (7-3)^2}$
 $= \sqrt{8^2 + 4^2} = \sqrt{80} = 4\sqrt{5}$ unit

Again,

\therefore The length of the side AD = The length of the side BC
 \therefore The lengths of the opposite sides are equal.
 Therefore we can say that, $ABCD$ is a parallelogram.

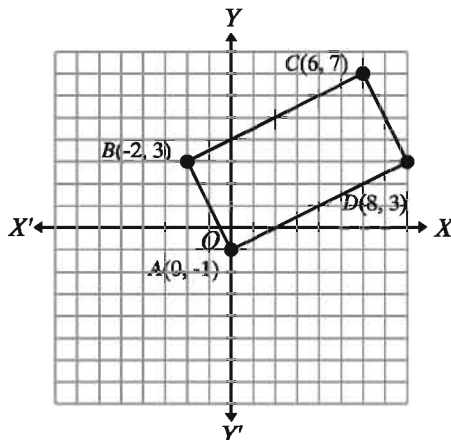

The length of the diagonal BD is $= \sqrt{(8 - (-2))^2 + (3 - 3)^2} = \sqrt{10^2 + (0)^2} = \sqrt{100} = 10$ unit

Now, $BD^2 = 100$, $AB^2 = (2\sqrt{5})^2 = 20$, $AD^2 = (4\sqrt{5})^2 = 80$

$\therefore AB^2 + AD^2 = 20 + 80 = 100 = BD^2$

As per the theorem of Pythagoras, ABD is a right angled triangle and $\angle BAD$ is a right angle. So, it is proved that, $ABCD$ is a rectangle.

Example 5. Show that the three points $(-3, -3)$, $(0, 0)$ and $(3, 3)$ do not form a triangle.

Solution: Let, $A(-3, -3)$, $B(0, 0)$ and $C(3, 3)$ are the given three points. Their position on the plane xy has been shown.

We know, the sum of the two sides of any triangle is greater than its third side. Let ABC is a triangle and AB , BC and AC be its three sides.

The length of the side AB is
 $= \sqrt{(0 - (-3))^2 + (0 - (-3))^2}$
 $= \sqrt{3^2 + 3^2} = \sqrt{18} = 3\sqrt{2}$ unit

The length of the side BC is
 $= \sqrt{(3 - 0)^2 + (3 - 0)^2}$
 $= \sqrt{3^2 + 3^2} = \sqrt{18} = 3\sqrt{2}$ unit

The length of the side AC is
 $= \sqrt{(3 + 3)^2 + (3 + 3)^2}$
 $= \sqrt{72} = 6\sqrt{2}$ unit

So, $AB + BC = 3\sqrt{2} + 3\sqrt{2} = 6\sqrt{2} = AC$

Therefore, the sum of the two sides is equal to the third side. So it is not possible to form a triangle with them.

Again seeing the positions of three points on plane xy , we can say that the three points are on a straight line and so no triangle can be formed by them.

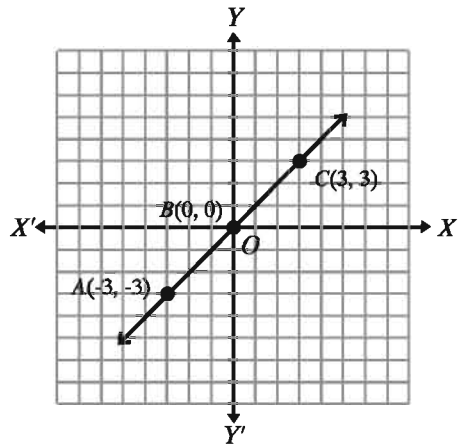

Exercises 11.1

- Find the distance between the given points in every case:
 - $(2, 3)$ and $(4, 6)$
 - $(-3, 7)$ and $(-7, 3)$
 - (a, b) and (b, a)
 - $(0, 0)$ and $(\sin\theta, \cos\theta)$
 - $\left(-\frac{3}{2}, -1\right)$ and $\left(\frac{1}{2}, 2\right)$
- The three vertices of a triangle are $A(2, -4)$, $B(-4, 4)$ and $C(3, 3)$ respectively. Draw the triangle and show that it is an isosceles triangle.
- $A(2, 5)$, $B(-1, 1)$ and $C(2, 1)$ are the three vertices of a triangle. Draw the triangle and show that it is a right angled triangle.
- Ascertain whether the points $A(1, 2)$, $B(-3, 5)$ and $C(5, -1)$ form a triangle.
- If the two points $(-5, 5)$ and $(5, k)$ are equidistant from the origin; find the value of k .
- Show that, $A(2, 2)$, $B(-2, -2)$ and $C(-2\sqrt{3}, 2\sqrt{3})$ are the vertices of an equilateral triangle. Find its perimeter upto three places of decimals.

7. Show that the points $A(-5, 0)$, $B(5, 0)$, $C(5, 5)$ and $D(-5, 5)$ are the four vertices of a rectangle.
8. Ascertain whether the quadrilateral formed with the points $A(-2, -1)$, $B(5, 4)$, $C(6, 7)$ and $D(-1, 2)$ is a parallelogram or a rectangle.
9. Which of the points $A(10, 5)$, $B(7, 6)$, $C(-3, 5)$ is the nearest to the point $P(3, -2)$ and which is the farthest?
10. From the point $P(x, y)$, the distance of the y -axis is equal to the distance of P from $Q(3, 2)$. Prove that, $y^2 - 4y - 6x + 13 = 0$
11. The vertices of the triangle ABC are $A(2, -1)$, $B(-4, 2)$, $C(2, 5)$. Find the value of the median AD .

Area of triangles

We know we get the region of a triangle if we connect straight lines with three different points that are not lying on the same straight line. That region of the triangle may be different respective of the side and the angle. In this part we will be able to determine the area of any triangle by finding the sides of the triangle with the help of only one formula. With the help of this same formula, by dividing any quadrilateral into the two triangles, the determination of the area of the region of the quadrilateral will be possible. In this case we will determine the area using the perimeter of the triangle (the sum of the lengths of the sides) and the length of the side. To determine the area of a triangle-shaped or angle-shaped land, the method i.e. by the length of side, is very important. So, it is very useful in determining the area of the land. It is said, as the reason, if the coordinates of the vertices of the triangular or quadrangular land are not known or are not possible to know but if the coordinates are known, we will be able to determine the area more easily. In this part we shall determine the area of a triangle or a polygon by these two methods.

Method 1: Determination of the Area Using the Length of Sides and Perimeter

The determination of the Area: A triangle ABC has been shown in the adjacent figure. $A(x_1, y_1)$, $B(x_2, y_2)$ and $C(x_3, y_3)$ are three different points and

AB, BC and CA are the three sides of the triangle. With the help of the formula of determining distance, it is possible to determine easily the lengths of the sides AB, BC and CA . For example:

Taking c as the length of side AB ,

$$c = \sqrt{(x_1 - x_2)^2 + (y_1 - y_2)^2} \text{ unit}$$

Taking a as the length of side BC ,

$$a = \sqrt{(x_2 - x_3)^2 + (y_2 - y_3)^2} \text{ unit}$$

Taking b as the length of side AC ,

$$b = \sqrt{(x_1 - x_3)^2 + (y_1 - y_3)^2} \text{ unit}$$

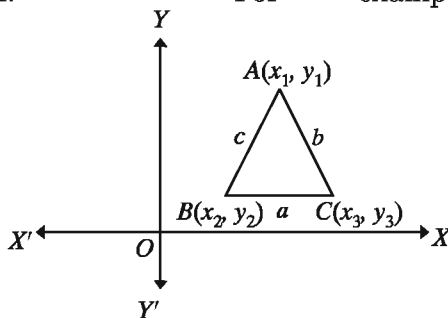

Now taking the perimeter of the triangle as $2s$,

$$2s = a + b + c \text{ [Perimeter = the sum of the lengths of the three sides.]}$$

So $s = \frac{1}{2}(a + b + c)$ unit, Here s is the half of the perimeter of the triangle

We can easily determine the area of any triangle with the help of s and a, b, c .

The Formula for Determining the Area of Triangular Region

If in ABC , the length of the side AB is c , the length of the side BC is a and the length of the side CA is b and perimeter is $2s$. So the area of $\triangle ABC$ is $\sqrt{s(s-a)(s-b)(s-c)}$ square unit [The proof has been given in the part of mensuration of the Mathematics book of class 9-10. The students should check out the proof.]

By the following examples, the use of the formula will be easily understood.

Observation: There are different formulas for determining the area of different triangles but here we shall be able to determine the area of any triangle with the help of only one theory.

Example 6. $A(2, 5)$, $B(-1, 1)$ and $C(2, 1)$ are the three vertices of a triangle. Draw a rough figure of the triangle and find its area by the perimeter and the length of its side. Determine what type of a triangle does it appear to be and justify your answer.

Solution: The triangle has been shown in the figure.

Length of the side AB is, $c =$

$$\sqrt{(-1-2)^2 + (1-5)^2}$$

$$= \sqrt{9+16} = 5 \text{ unit}$$

Length of the side BC is, $a =$

$$\sqrt{(2+1)^2 + (1-1)^2}$$

$$= \sqrt{9+0} = 3 \text{ unit}$$

Length of the side AC is, $b =$

$$\sqrt{(2-2)^2 + (1-5)^2}$$

$$= \sqrt{0+16} = 4 \text{ unit}$$

$$s = \frac{1}{2}(a+b+c) = \frac{1}{2}(3+4+5)$$

$$= \frac{12}{2} = 6 \text{ unit}$$

$$\therefore \text{Area} = \sqrt{s(s-a)(s-b)(s-c)} \text{ square unit}$$

$$= \sqrt{6(6-3)(6-4)(6-5)} \text{ square unit}$$

$$= \sqrt{6 \times 3 \times 2 \times 1} \text{ square unit}$$

$$= \sqrt{6 \times 6} = 6 \text{ square unit}$$

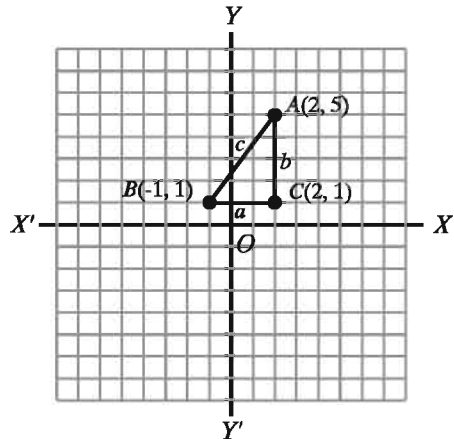

From the figure we can understand that it is a right angled triangle. It can be proved easily by the theorem of Pythagoras.

$$AB^2 = c^2 = 5^2 = 25, BC^2 = a^2 = 3^2 = 9, CA^2 = b^2 = 4^2 = 16$$

$$\therefore BC^2 + CA^2 = 9 + 16 = 25 = AB^2$$

$\therefore ABC$ is a right angle triangle. AB is hypotenuse and $\angle ACB$ is a right angle.

Example 7. $A(2, -4)$, $B(-4, 4)$ and $C(3, 3)$ are the three vertices of a triangle. Draw the triangle and find the area by determining the length of the side. Determine what type of a triangle does it appear to be and give a name of it and justify your contention.

Solution: The triangle is shown in the figure.

$$\begin{aligned}
 AB = c &= \sqrt{(-4 - 2)^2 + (4 - (-4))^2} \\
 &= \sqrt{36 + 64} = \sqrt{100} = 10 \text{ unit} \\
 BC = a &= \sqrt{(3 - (-4))^2 + (3 - 4)^2} \\
 &= \sqrt{49 + 1} = \sqrt{50} = 5\sqrt{2} \text{ unit} \\
 CA = b &= \sqrt{(2 - 3)^2 + (-4 - 3)^2} \\
 &= \sqrt{1 + 49} = \sqrt{50} = 5\sqrt{2} \text{ unit} \\
 \text{Now, } s &= \frac{1}{2}(a + b + c) = \frac{1}{2}(10 + 5\sqrt{2} + 5\sqrt{2}) \\
 &= 5 + 5\sqrt{2} \text{ unit}
 \end{aligned}$$

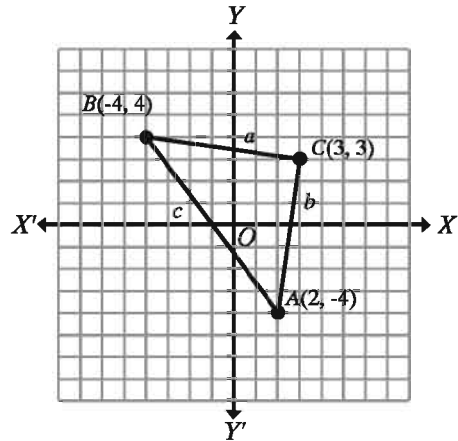

$$\begin{aligned}
 \therefore \text{Area} &= \sqrt{s(s - a)(s - b)(s - c)} \text{ square unit} \\
 &= \sqrt{(5 + 5\sqrt{2})(5 + 5\sqrt{2} - 10)(5 + 5\sqrt{2} - 5\sqrt{2})(5 + 5\sqrt{2} - 5\sqrt{2})} \text{ square unit} \\
 &= \sqrt{(5 + 5\sqrt{2})(5\sqrt{2} - 5) \cdot 5 \cdot 5} \text{ square unit} \\
 &= 5\sqrt{(5 + 5\sqrt{2})(5\sqrt{2} - 5)} \text{ square unit} \\
 &= 5\sqrt{(5\sqrt{2})^2 - 5^2} = 5\sqrt{50 - 25} = 5\sqrt{25} \text{ square unit} = 25 \text{ square unit}
 \end{aligned}$$

The given triangle is an isosceles triangle. Because $BC = CA = 5\sqrt{2}$ unit i.e., the two sides of the triangle is equal.

$$\text{Again, } AB^2 = 10^2 = 100$$

$$BC^2 + CA^2 = (5\sqrt{2})^2 + (5\sqrt{2})^2 = 50 + 50 = 100$$

$$\therefore AB^2 = BC^2 + CA^2$$

$\therefore \triangle ABC$ is a right angled triangle.

So $\triangle ABC$ is a right angled and isosceles triangle.

Example 8. The three vertices of a triangle are $A(-2, 0)$, $B(5, 0)$ and $C(1, 4)$ respectively. Find the length of each side and the area of the triangle.

Solution: The triangle is shown in the figure.

$$AB = c = \sqrt{(5 - (-2))^2 + (0 - 0)^2}$$

$$= \sqrt{49} = 7 \text{ unit}$$

$$BC = a = \sqrt{(1 - 5)^2 + (4 - 0)^2}$$

$$= \sqrt{16 + 16} = 4\sqrt{2} \text{ unit}$$

$$CA = b = \sqrt{(-2 - 1)^2 + (0 - 4)^2}$$

$$= \sqrt{9 + 16} = 5 \text{ unit}$$

$$s = \frac{1}{2}(a + b + c) = \frac{1}{2}(7 + 4\sqrt{2} + 5)$$

$$= \frac{1}{2}(12 + 4\sqrt{2}) = 6 + 2\sqrt{2} \text{ unit}$$

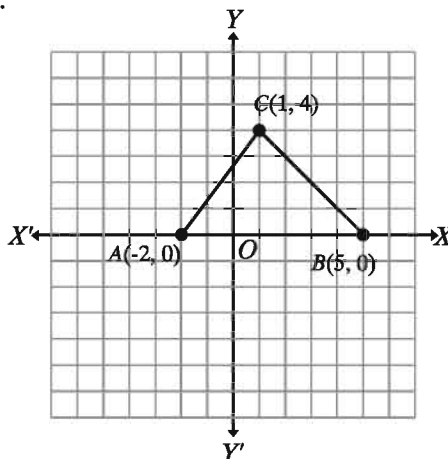

$$\therefore \text{Area} = \sqrt{s(s-a)(s-b)(s-c)} \text{ square unit}$$

$$= \sqrt{(6 + 2\sqrt{2})(6 + 2\sqrt{2} - 7)(6 + 2\sqrt{2} - 4\sqrt{2})(6 + 2\sqrt{2} - 5)} \text{ square unit}$$

$$= \sqrt{(6 + 2\sqrt{2})(2\sqrt{2} - 1)(6 - 2\sqrt{2})(2\sqrt{2} + 1)} \text{ square unit}$$

$$= \sqrt{(6 + 2\sqrt{2})(6 - 2\sqrt{2})(2\sqrt{2} + 1)(2\sqrt{2} - 1)} \text{ square unit}$$

$$= \sqrt{(6^2 - (2\sqrt{2})^2)((2\sqrt{2})^2 - 1^2)} = \sqrt{28 \cdot 7} = 14 \text{ square unit}$$

The given triangle is an obtuse angled triangle. Because, it has no side equal to its any other side.

Observation: Among the three triangular regions whose area we have determined, the first one is a right angled triangle, the second one is an isosceles triangle and the third one is an obtuse angled triangle. The area of each triangle has been determined with the help of only one formula. In the same way we can determine the area of any other triangle. There will be more problems related to the area of triangles in the exercise.

Example 9. $A(1, 0)$, $B(0, 1)$, $C(-1, 0)$ and $D(0, -1)$ are four vertices of a quadrilateral. Draw the quadrilateral and find the area by determining its length of any two sides and the diagonals.

Solution: In the adjacent figure by plotting the points, the quadrilateral $ABCD$ is shown. AB, BC, CD and DA are the four sides of the quadrilateral and AC and BD are the two diagonals of the quadrilateral.

$$\begin{aligned} \text{Side } AB = c &= \sqrt{(1-0)^2 + (0-1)^2} \\ &= \sqrt{1+1} = \sqrt{2} \text{ unit} \end{aligned}$$

$$\begin{aligned} \text{Side } BC = a &= \sqrt{(0+1)^2 + (1-0)^2} \\ &= \sqrt{1+1} = \sqrt{2} \text{ unit} \end{aligned}$$

$$\begin{aligned} \text{Side } AC = b &= \sqrt{(1+1)^2 + (0-0)^2} \\ &= \sqrt{2^2} = 2 \text{ unit} \end{aligned}$$

$$\begin{aligned} \text{Side } CD &= \sqrt{(-1-0)^2 + (0+1)^2} = \sqrt{2} \\ &\text{unit} \end{aligned}$$

$$\begin{aligned} \text{Side } DA &= \sqrt{(0-1)^2 + (-1-0)^2} = \sqrt{2} \\ &\text{unit} \end{aligned}$$

We can see that, $AB = BC = CD = DA = \sqrt{2}$ unit

\therefore The quadrilateral is a square or a rhombus.

$$\text{Now, } AB^2 + BC^2 = (\sqrt{2})^2 + (\sqrt{2})^2 = 2 + 2 = 4 = AC^2$$

\therefore The quadrilateral is a square.

The area of the quadrilateral $ABCD = 2 \times$ the area of the triangle ABC .

$$\begin{aligned} \text{Now the perimeter of the triangle } ABC &= 2s = AB + BC + CA = \sqrt{2} + \sqrt{2} + 2 = \\ &= 2 + 2\sqrt{2} \text{ unit} \end{aligned}$$

$$s = \frac{1}{2}(2 + 2\sqrt{2}) = 1 + \sqrt{2} \text{ unit}$$

\therefore The area of the triangle ABC is $= \sqrt{(s-a)(s-b)(s-c)}$ square unit

$$= \sqrt{(1 + \sqrt{2})(1 + \sqrt{2} - \sqrt{2})(1 + \sqrt{2} - 2)(1 + \sqrt{2} - \sqrt{2})} \text{ square unit}$$

$$= \sqrt{(\sqrt{2} + 1) \cdot 1 \cdot (\sqrt{2} - 1) \cdot 1} \text{ square unit}$$

$$= \sqrt{(\sqrt{2})^2 - 1} \text{ square unit} = \sqrt{2 - 1} \text{ square unit} = 1 \text{ square unit}$$

\therefore The area of the quadrilateral $ABCD$ is $= 2 \times 1$ square unit $= 2$ square unit.

Remark: By squaring the length of a square, the area can also be found. By multiplying the length and the breadth of a rectangle, the area is also to be found. But the area of any quadrilateral can not to be determined.

Example 10. Draw the quadrilateral having its vertices at the points $A(-1, 1)$, $B(2, -1)$, $C(3, 3)$ and $D(1, 6)$. Find the length of its each side and one of its diagonals and also the area of the quadrilateral.

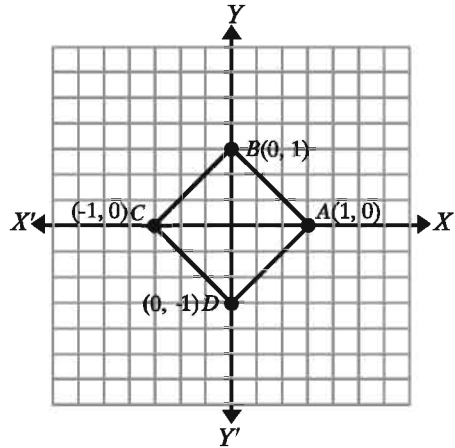

Solution: By plotting the points on the plane xy , the quadrilateral $ABCD$ is shown. In the quadrilateral $ABCD$,

$$\text{Side } AB = a = \sqrt{3^2 + 2^2} = \sqrt{13} \text{ unit}$$

$$\text{Side } BC = b = \sqrt{1^2 + 4^2} = \sqrt{17} \text{ unit}$$

$$\text{Side } CD = d = \sqrt{2^2 + 3^2} = \sqrt{13} \text{ unit}$$

$$\text{Side } DA = e = \sqrt{2^2 + 5^2} = \sqrt{29} \text{ unit}$$

$$\text{Diagonal } AC = c = \sqrt{4^2 + 2^2} = \sqrt{20} \text{ unit}$$

$$\text{In } \triangle ABC, 2s = a + b + c = (\sqrt{13} + \sqrt{17} + \sqrt{20}) \text{ unit}$$

$$= (3.6056 + 4.1231 + 4.4721) \text{ unit} = 12.2008 \text{ unit}$$

$$\therefore s = 6.1004 \text{ unit}$$

$$\text{Area of } \triangle ABC \text{ is } = \sqrt{s(s-a)(s-b)(s-c)} \text{ square unit}$$

$$= \sqrt{6.1004 \times 2.4948 \times 1.9773 \times 1.6283} \text{ square unit}$$

$$= \sqrt{49.000} \text{ square unit} = 7 \text{ square unit}$$

$$\text{In } \triangle ACD, 2s = c + d + e = (\sqrt{20} + \sqrt{13} + \sqrt{29}) \text{ unit}$$

$$= (4.4721 + 3.6056 + 5.3852) \text{ unit} = 13.4629 \text{ unit}$$

$$\therefore s = 6.7315 \text{ unit.}$$

$$\text{Area of } \triangle ACD \text{ is } = \sqrt{s(s-c)(s-d)(s-e)} \text{ square unit}$$

$$= \sqrt{6.7315 \times 2.2591 \times 3.1256 \times 1.3460} \text{ square unit}$$

$$= \sqrt{63.9744} \text{ square unit} = 7.9983 \text{ square unit}$$

$$\therefore \text{Area of the quadrilateral } ABCD \text{ is } = (7.000 + 7.998) \text{ square unit}$$

$$= 14.998 \text{ square unit} = 15 \text{ square unit (app.).}$$

Remark: The quadrilateral is not a square or a rectangle or a parallelogram or a rhombus. This method is very useful in determining the area of such an obtuse shaped land.

Example 11. The coordinates of the four points are respectively $A(2, -3)$, $B(3, 0)$, $C(0, 1)$ and $D(-1, -2)$.

- 1) Show that $ABCD$ is a rhombus.
- 2) Find the length of AC and BD and ascertain whether $ABCD$ is a square.
- 3) Find the area of the quadrilateral by the region of triangle.

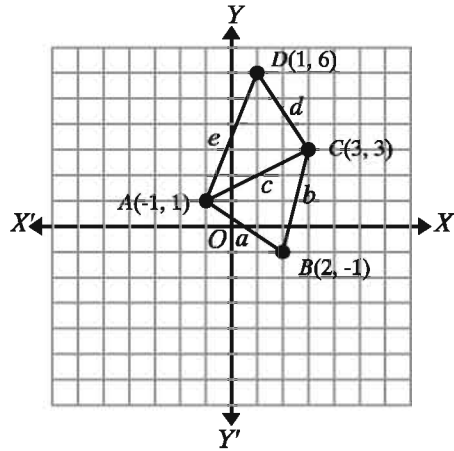

Solution: By plotting the points, the quadrilateral $ABCD$ has been shown in the figure.

- 1) Suppose, a, b, c, d are the length of the sides AB, BC, CD and DA respectively and the diagonal $AC = e$ and the diagonal $BD = f$.

$$a = \sqrt{(3-2)^2 + (0+3)^2} = \sqrt{1^2 + 3^2} = \sqrt{10} \text{ unit}$$

$$b = \sqrt{(0-3)^2 + (1-0)^2} = \sqrt{3^2 + 1^2} = \sqrt{10} \text{ unit}$$

$$c = \sqrt{(-1-0)^2 + (-2-1)^2} = \sqrt{1^2 + 3^2} = \sqrt{10} \text{ unit}$$

$$d = \sqrt{(2+1)^2 + (-3+2)^2} = \sqrt{3^2 + 1^2} = \sqrt{10} \text{ unit}$$

Since $a = b = c = d = \sqrt{10}$ unit

$\therefore ABCD$ is a rhombus.

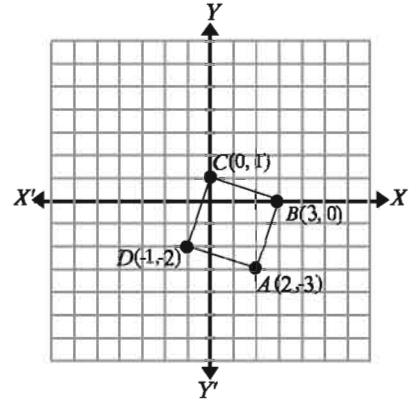

- 2) Diagonal $AC = e = \sqrt{(0-2)^2 + (1+3)^2} = \sqrt{4+16} = \sqrt{20}$ unit
and diagonal $BD = f = \sqrt{(-1-3)^2 + (-2-0)^2} = \sqrt{4^2+2^2} = \sqrt{20}$ unit
 \therefore It is seen that $AC = BD$ therefore, the diagonals are equal.

$$AC^2 = (\sqrt{20})^2 = 20$$

$$AB^2 + BC^2 = (\sqrt{10})^2 + (\sqrt{10})^2 = 10 + 10 = 20 = AC^2$$

\therefore According to the theorem of Pythagoras $\angle ABC$ is a right angle.

\therefore The quadrilateral $ABCD$ is a square.

- 3) Area of the quadrilateral $ABCD$ is $= 2 \times$ area of the triangle ABC

Here in the case of $\triangle ABC$,

$$s = \frac{1}{2}(a + b + e) = \frac{\sqrt{10} + \sqrt{10} + \sqrt{20}}{2} = \frac{2\sqrt{10} + 2\sqrt{5}}{2} = \sqrt{10} + \sqrt{5}$$

\therefore Area of $\triangle ABC$,

$$= \sqrt{s(s-a)(s-b)(s-e)} \text{ square unit}$$

$$= \sqrt{(\sqrt{10} + \sqrt{5})(\sqrt{10} + \sqrt{5} - \sqrt{10})(\sqrt{10} + \sqrt{5} - \sqrt{10})(\sqrt{10} + \sqrt{5} - \sqrt{20})} \text{ square unit}$$

$$= \sqrt{(\sqrt{10} + \sqrt{5}) \cdot \sqrt{5} \cdot \sqrt{5} \cdot (\sqrt{10} - \sqrt{5})} \text{ square unit}$$

$$= \sqrt{5 \cdot ((\sqrt{10})^2 - (\sqrt{5})^2)} = \sqrt{5 \cdot 5} = 5 \text{ square unit}$$

\therefore Area of square $ABCD$ is $= 2 \times 5$ square unit $= 10$ square unit.

Remark: Easy method: the area of a square $ABCD = (\sqrt{10})^2 = 10$ square unit.

Method 2: Determination of the Area Using the Coordinates of the Vertices

By this method the area of a triangle can be determined very easily with the help of the coordinates of the three vertices of a triangle. If the coordinates of the vertices of any polygon are known, the area of the polygon can also be determined in the same way. However, in real life, it is not possible to use this method. This is because if we want to determine the area of a land and if the shape of the land is triangle or square, the area can not be determined by this method since the coordinates of the angular points are not known or are not possible to know. But we can easily measure the length of the sides of a land and determine the area by the Method 1. So, it is necessary for the students to have conceptions about both methods. Method 2 for determining the area of triangles and polygons is discussed below with examples:

The General Formula of Determining the Area of a Triangle: Let, $A(x_1, y_1)$, $B(x_2, y_2)$ and $C(x_3, y_3)$ be the three vertices of the triangle ABC . Like the figure similar to below, the points A , B and C are arranged in anti-clockwise order.

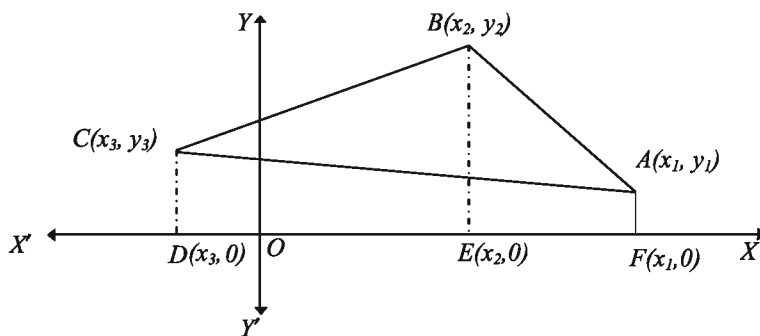

From the figure we get,

Area of polygon $ABCDF$ = area of triangle ABC + area of trapezium $ACDF$.
 $=$ area of trapezium $ABEF$ + area of trapezium $BCDE$.

Therefore we get,

Area of triangle ABC = area of trapezium $ABEF$ + area of trapezium $BCDE$

– area of trapezium $ACDF$.

\therefore Area of the Triangle ABC

$$\begin{aligned}
 &= \frac{1}{2} \times (BE + AF) \times EF + \frac{1}{2} \times (CD + BE) \times DE - \frac{1}{2} \times (CD + AF) \times DF \\
 &= \frac{1}{2} \times (y_2 + y_1) \times (x_1 - x_2) + \frac{1}{2} \times (y_3 + y_2) \times (x_2 - x_3) - \frac{1}{2} \times (y_3 + y_1) \times (x_1 - x_3) \\
 &= \frac{1}{2} (x_1y_2 + x_2y_3 + x_3y_1 - x_2y_1 - x_3y_2 - x_1y_3) \\
 &= \frac{1}{2} \begin{vmatrix} x_1 & x_2 & x_3 & x_1 \\ y_1 & y_2 & y_3 & y_1 \end{vmatrix} \quad \text{বর্গ একক}
 \end{aligned}$$

Where in the side of multiplication as the positive sign \searrow we get $x_1y_2 + x_2y_3 + x_3y_1$ and as the negative sign \nearrow we get $-x_2y_1 - x_3y_2 - x_1y_3$

So, area of triangle $\triangle ABC = \frac{1}{2} \begin{vmatrix} x_1 & x_2 & x_3 & x_1 \\ y_1 & y_2 & y_3 & y_1 \end{vmatrix}$ square unit

Remark: It is very important to remember that in applying this formula, the vertices $\begin{vmatrix} x_1 & x_2 & x_3 & x_1 \\ y_1 & y_2 & y_3 & y_1 \end{vmatrix}$ must be taken in anti-clockwise order.

Example 12. Find the area of the triangle ABC with the vertices $A(2, 3)$, $B(5, 6)$ and $C(-1, 4)$.

Solution: The vertices $A(2, 3)$, $B(5, 6)$ and $C(-1, 4)$ are taken in anti-clockwise order.

$$\begin{aligned}
 \text{Area of } \triangle ABC &= \frac{1}{2} \begin{vmatrix} 2 & 5 & -1 & 2 \\ 3 & 6 & 4 & 3 \end{vmatrix} \text{ square} \\
 &\text{unit} \\
 &= \frac{1}{2} (12 + 20 - 3 - 15 + 6 - 8) \text{ square unit} \\
 &= \frac{1}{2} (12) \text{ square unit} = 6 \text{ square unit}
 \end{aligned}$$

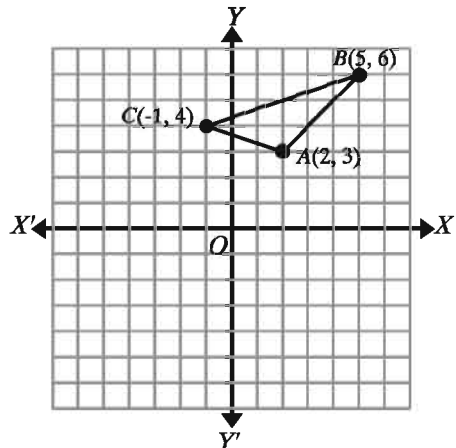

Example 13. The vertices of a triangle are $A(1, 3)$, $B(5, 1)$ and $C(3, r)$ and its area is 4 square unit. Find the possible value of r .

Solution: Considering the vertices $A(1, 3)$, $B(5, 1)$ and $C(3, r)$ are in anticlockwise order, the area of $\triangle ABC$ is

$$\begin{aligned} &= \frac{1}{2} \begin{vmatrix} 1 & 5 & 3 & 1 \\ 3 & 1 & r & 3 \end{vmatrix} \text{ square unit} \\ &= \frac{1}{2} (1 + 5r + 9 - 15 - 3 - r) \text{ square unit} \\ &= \frac{1}{2} (4r - 8) = (2r - 4) \text{ square unit} \end{aligned}$$

According to the question, $|(2r - 4)| = 4$

$$\text{or, } \pm(2r - 4) = 4$$

$$\text{or, } 2r - 4 = \pm 4$$

Therefore, $2r = 0$ or, 8

$$\therefore r = 0, 4$$

Area of Quadrilateral

In the figure below $ABCD$ is a quadrilateral. Its vertices are $A(x_1, y_1)$, $B(x_2, y_2)$, $C(x_3, y_3)$, $D(x_4, y_4)$ respectively and A, B, C, D are arranged in anti-clockwise order.

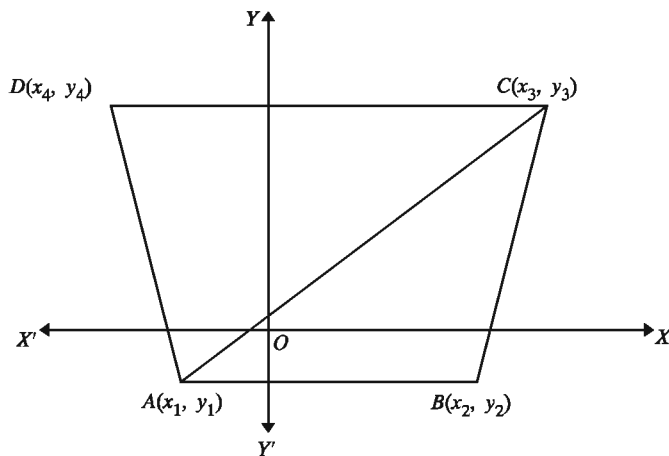

Now area of quadrilateral $ABCD = \text{area of triangle } ABC + \text{area of triangle } ACD$

$$\begin{aligned} &= \frac{1}{2} \begin{vmatrix} x_1 & x_2 & x_3 & x_1 \\ y_1 & y_2 & y_3 & y_1 \end{vmatrix} + \frac{1}{2} \begin{vmatrix} x_1 & x_3 & x_4 & x_1 \\ y_1 & y_3 & y_4 & y_1 \end{vmatrix} \\ &= \frac{1}{2} (x_1y_2 + x_2y_3 + x_3y_1 - x_2y_1 - x_3y_2 - x_1y_3) + \frac{1}{2} (x_1y_3 + x_3y_4 + x_4y_1 - x_3y_1 - x_4y_3 - x_1y_4) \end{aligned}$$

$$= \frac{1}{2}(x_1y_2 + x_2y_3 + x_3y_4 + x_4y_1 - x_2y_1 - x_3y_2 - x_4y_3 - x_1y_4)$$

So, the area of Quadrilateral $ABCD$

$$= \frac{1}{2} \begin{vmatrix} x_1 & x_2 & x_3 & x_4 & x_1 \\ y_1 & y_2 & y_3 & y_4 & y_1 \end{vmatrix} \text{ square unit}$$

Similarly, if $A(x_1, y_1)$, $B(x_2, y_2)$, $C(x_3, y_3)$, $D(x_4, y_4)$ and $E(x_5, y_5)$ are the vertices of a pentagon $ABCDE$, and if the vertices are arranged in anticlockwise order, the area of the pentagon $ABCDE$ is the sum of the area of the three triangles ABC , ACD and ADE .

Like the area of the triangle and the quadrilateral, just in the same way, the area of the pentagon $ABCDE = \frac{1}{2} \begin{vmatrix} x_1 & x_2 & x_3 & x_4 & x_5 & x_1 \\ y_1 & y_2 & y_3 & y_4 & y_5 & y_1 \end{vmatrix}$ square unit

If the coordinates of the vertices of any polygon are to be known, in the same way we can determine the area easily following the above method.

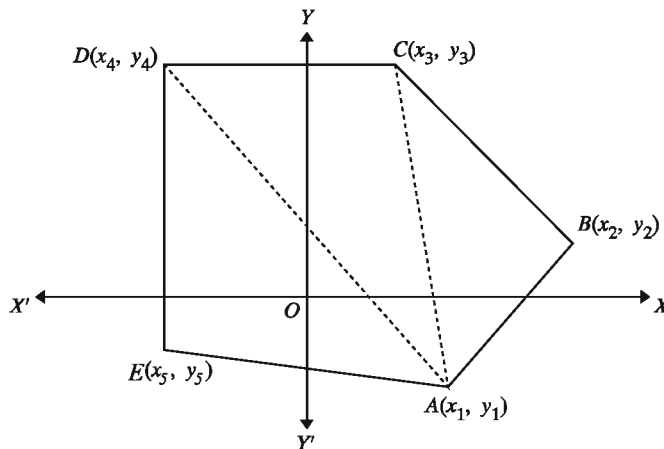

Work: Establish the formula for the area of hexagon with the help of the method of determining the area of quadrilateral.

Example 14. Find the area of the quadrilateral $ABCD$ with vertices $A(1, 4)$, $B(-4, 3)$, $C(1, -2)$ and $D(4, 0)$.

Solution: Taking the vertices in anti-clockwise order, the area of the quadrilateral is

$$\begin{aligned} ABCD &= \frac{1}{2} \begin{vmatrix} 1 & -4 & 1 & 4 & 1 \\ 4 & 3 & -2 & 0 & 4 \end{vmatrix} \text{ square unit} \\ &= \frac{1}{2}(3 + 8 + 0 + 16 + 16 - 3 + 8 - 0) \text{ square unit} \\ &= \frac{1}{2}(48) \text{ square unit} = 24 \text{ square unit} \end{aligned}$$

Exercise 11.2

1. $A(-2, 0)$, $B(5, 0)$ and $C(1, 4)$ are respectively the vertices of $\triangle ABC$.
 - 1) Find the lengths of the sides AB , BC , CA and the perimeter of $\triangle ABC$.
 - 2) Find the area of the triangles.
2. In each case find the area of the triangle ABC :
 - 1) $A(2, 3)$, $B(5, 6)$ and $C(-1, 4)$
 - 2) $A(5, 2)$, $B(1, 6)$ and $C(-2, -3)$
3. Show that the points $A(1, 1)$, $B(4, 4)$, $C(4, 8)$ and $D(1, 5)$ are the vertices of a parallelogram. Find the lengths of the sides AC and BD . Find the area of the parallelogram using area of triangle upto three places of decimals.
4. What is the area of the quadrilateral $ABCD$ with the vertices $A(-a, 0)$, $B(0, -a)$, $C(a, 0)$ and $D(0, a)$?
5. Show that the four points $A(0, -1)$, $B(-2, 3)$, $C(6, 7)$ and $D(8, 3)$ are the vertices of a rectangle. Find the lengths of its diagonals and the area of the rectangle.
6. If $AB = BC$ holds for the coordinates of the three points respectively $A(-2, 1)$, $B(10, 6)$ and $C(a, -6)$, find the possible value of a . Then find the area of the triangle formed with the help of the value of a .
7. The coordinates of the three points A, B, C are respectively $A(a, a + 1)$, $B(-6, -3)$ and $C(5, -1)$. If the length of AB is twice of AC , find the possible value of a and describe the properties of the triangle ABC .
8. Find the area of the quadrilaterals as follows. [Use method no. 2]:
 - 1) $(0, 0)$, $(-2, 4)$, $(6, 4)$, $(4, 1)$
 - 2) $(1, 4)$, $(-4, 3)$, $(1, -2)$, $(4, 0)$
 - 3) $(0, 1)$, $(-3, -3)$, $(4, 3)$, $(5, 1)$
9. Show that the the area of the polygon with vertices $A(2, -3)$, $B(3, -1)$, $C(2, 0)$, $D(-1, 1)$ and $E(-2, -1)$ is 11 square unit.
10. The vertices of a quadrilateral, arranged in anti-clockwise order, $A(3, 4)$, $B(-4, 2)$, $C(6, -1)$ and $D(p, 3)$. Find the value of p if the area of the quadrilateral $ABCD$ is twice the area of the triangle ABC .

Gradient or slope of a straight line

In this part of Coordinate Geometry, at first we shall discuss what Gradient or Slope means and how to determine the Slope or the Gradient of a straight line. By using the concept of the slope how the algebraic form of the straight line appears to be will be discussed. If any straight line passes through two points, the nature of that straight line and the determination of the equation of that straight line are mainly the subject matter of the discussion. If two straight lines meet or intersect at any point, determining the coordinates of that intersecting point and triangles formed by three straight lines denoted by three equations will also be discussed.

Gradient or slope

In the figure beside, let's consider the straight line AB . The line passes through the two points $A(2, 3)$ and $B(6, 7)$. According to the figure, the line produces an angle θ with the positive side of x axis. The angle θ is the measurement of the inclination of the straight line AB with the horizontal x -axis. In Coordinate Geometry, we measure the Gradient m of the line AB in the following way:

$$m = \frac{\text{Change of the coordinate of } y}{\text{Change of the coordinate of } x} = \frac{7 - 3}{6 - 2} = \frac{4}{4} = 1$$

\therefore gradient of the line AB , $m = 1$

Generally, when a straight line AB passes through the points $A(x_1, y_1)$ and $B(x_2, y_2)$, we express the gradient (m) as

$$m = \frac{y_2 - y_1}{x_2 - x_1} \left[\frac{\text{rise}}{\text{run}} \right] = \frac{\text{rise}}{\text{run}}$$

In reality, the relation between the slope m and the angle θ produced by any straight line with the positive side of x -axis is, $m = \tan\theta$. In the figure above, in case of AB , slope of the line is $m = 1$ i.e., $\tan\theta = 1$ or, $\theta = 45^\circ$ (an acute angle)

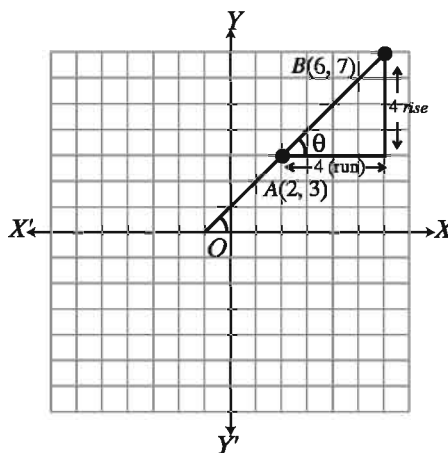

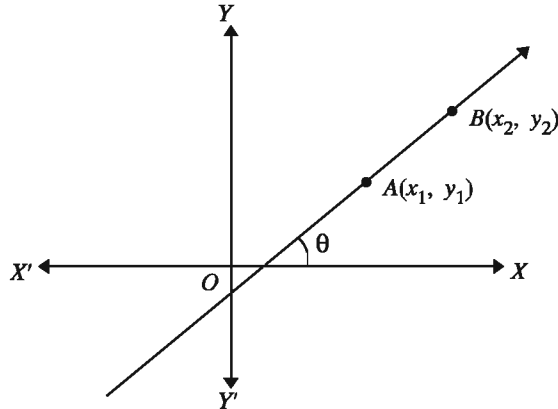

Example 15. In each of the following cases find the slope of the straight line passing through the given pair of points:

- 1) $A(2, 3)$ and $B(3, 6)$
- 2) $A'(2, 1)$ and $B'(-1, 4)$

Solution:

$$1) \text{ Slope of the line } AB = \frac{\text{rise}}{\text{run}} = \frac{6 - 3}{3 - 2} = \frac{3}{1} = 3$$

$$2) \text{ Slope of the line } A'B' = \frac{\text{rise}}{\text{run}} = \frac{4 - 1}{-1 - 2} = \frac{3}{-3} = -1$$

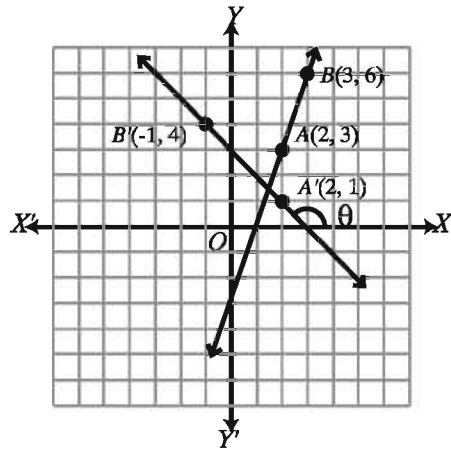

Note: In the above figure, it can be seen that the slope of the line AB is positive and the angle produced is an acute angle. Again from the same figure, it is clear that the slope of the line $A'B'$ is negative and the angle produced is an obtuse angle. Therefore, from the above discussion we come to the conclusion, if the slope is positive, the angle produced by the line with the positive side of the x -axis is an acute angle and if the slope is negative, the angle produced by the line with the positive side of the x -axis is an obtuse angle.

If the produced angle is zero or right angle, what will be the slope? This has been explained with the help of the following example:

Example 16. The coordinates of the three points A, B and C are respectively $(2, 2), (5, 2)$ and $(2, 7)$. Draw the lines AB and AC on the Cartesian plane. If possible, find the slopes of the lines AB and AC .

Solution: The lines AB and AC have been drawn on the Cartesian plane.

From the figure, it is observed that the line AB is parallel to the x axis, while the line AC is parallel to the y -axis.

$$\text{Slope of } AB, m = \frac{y_2 - y_1}{x_2 - x_1} = \frac{2 - 2}{5 - 2} = \frac{0}{3} = 0$$

Slope of AC can not be determined by the formula $m = \frac{y_2 - y_1}{x_2 - x_1}$ because $x_1 = x_2 = 2$ and $x_2 - x_1 = 0$. If $x_1 = x_2$ then the slope of the line is not determined but the line is parallel to the y -axis.

Generally any straight line passing through the point $A(x_1, y_1)$ and $B(x_2, y_2)$ has the slope,

$$m = \frac{y_2 - y_1}{x_2 - x_1}, m = \frac{y_1 - y_2}{x_1 - x_2} \text{ if } x_1 \neq x_2$$

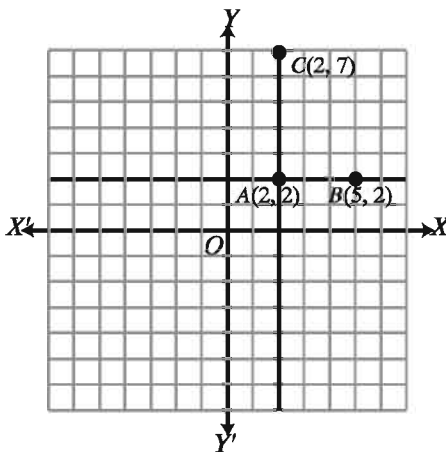

Observe: If $x_1 = x_2$, the line is parallel to the y -axis i.e., a perpendicular on the x -axis. It is not possible to walk on the perpendicular line or the vertical line. So, the determination of the slope is not possible.

Remark: In the above figure, on any point of the line AB , the ordinate i.e., $y = 2$ and on any point of the line AC , the abscissa i.e., $x = 2$. Therefore, the equation of the straight line AB is $y = 2$ and the equation of the straight line AC is $x = 2$.

Example 17. Find the slope of the line passing through the points $A(-3, 2)$ and $B(3, -2)$.

Solution: If m is the slope of AB , then

$$m = \frac{y_2 - y_1}{x_2 - x_1} = \frac{\text{rise}}{\text{run}} = \frac{2 - (-2)}{-3 - 3} = \frac{4}{-6} = \frac{2}{-3}$$

As the slope is negative, the angle produced by the line with the positive direction of the x -axis is an obtuse angle.

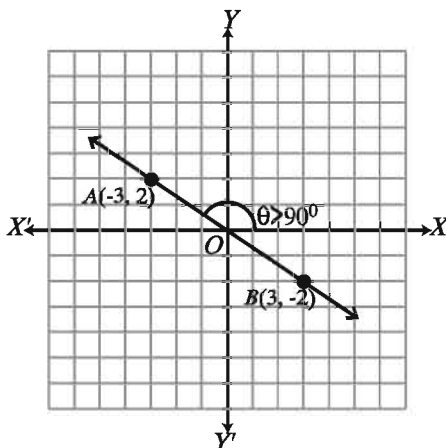

Example 18. What is the value of t if the three points $A(1, -1)$, $B(2, 2)$ and $C(4, t)$ are collinear?

Solution: As they are collinear, their slopes will be same. So, we get,

$$\frac{2+1}{2-1} = \frac{t-2}{4-2}$$

$$\text{or, } \frac{3}{1} = \frac{t-2}{2}$$

$$\text{or, } t-2 = 6$$

$$\text{or, } t = 8$$

So, value of t is 8.

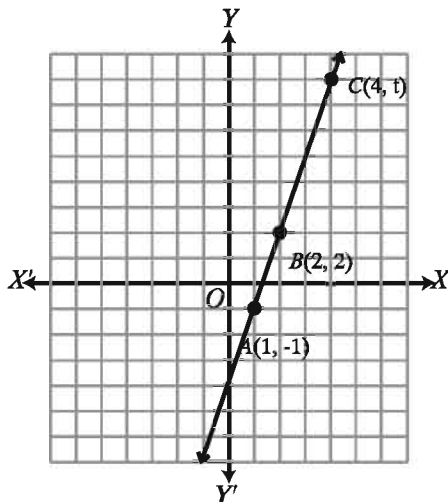

Example 19. $A(t, 3t)$, $B(t^2, 2t)$, $C(t-2, t)$ and $D(1, 1)$ are the four different points. If the lines AB and CD are parallel, find the admissible value of t .

Solution: Slope of AB , $m_1 = \frac{2t-3t}{t^2-t} = \frac{-t}{t(t-1)} = \frac{1}{1-t}$

Slope of CD , $m_2 = \frac{1-t}{1-t+2} = \frac{1-t}{3-t}$

As the lines AB and CD are parallel, they have the same slope i.e., $m_1 = m_2$

$$\text{or, } \frac{1}{1-t} = \frac{1-t}{3-t}$$

$$\text{or, } (1-t)^2 = (3-t)$$

$$\text{or, } 1-2t+t^2 = 3-t$$

$$\text{or, } t^2 - t - 2 = 0$$

$$\text{or, } t = -1 \text{ or } t = 2$$

So, possible values of t are -1 and 2

Exercise 11.3

1. In each case below, find the slope of the straight line passing through the points A and B .

1) $A(5, -2)$ and $B(2, 1)$

2) $A(3, 5)$ and $B(-1, -1)$

3) $A(t, t)$ and $B(t^2, t)$

4) $A(t, t+1)$ and $B(3t, 5t+1)$

- The three different points $A(t, 1)$, $B(2, 4)$ and $C(1, t)$ are collinear; find the value of t .
- Show that the points $A(0, -3)$, $B(4, -2)$ and $C(16, 1)$ are collinear.
- If the points $A(1, -1)$, $B(t, 2)$ and $C(t^2, t + 3)$ are collinear, find the admissible value of t .
- Find the value of p if the line joining the points $A(3, 3p)$ and $B(4, p^2 + 1)$ has slope -1 .
- Prove that the points $A(a, 0)$, $B(0, b)$ and $C(1, 1)$ are collinear if $\frac{1}{a} + \frac{1}{b} = 1$.
- If the points $A(a, b)$, $B(b, a)$ and $C\left(\frac{1}{a}, \frac{1}{b}\right)$ are collinear, prove that, $a + b = 0$.

Equation of Straight Lines

Suppose, a definite straight line L passes through two definite points $A(3, 4)$ and $B(5, 7)$. In the figure below, the line is shown.

Then the slope of the straight line AB is

$$m_1 = \frac{7 - 4}{5 - 3} = \frac{3}{2} \dots (1)$$

Suppose, $P(x, y)$ is any point on the line

L . Then the slope of the line AP is $m_2 = \frac{y - 4}{x - 3} \dots (2)$

Since AB and AP are segments of the same line, both have the same slope. i.e.

$$m_1 = m_2$$

$$\text{or, } \frac{3}{2} = \frac{y - 4}{x - 3} \text{ [From (1) and (2)]}$$

$$\text{or, } 3x - 9 = 2y - 8$$

$$\text{or, } 2y = 3x - 1$$

$$\text{or, } y = \frac{3}{2}x - \frac{1}{2} \dots (3)$$

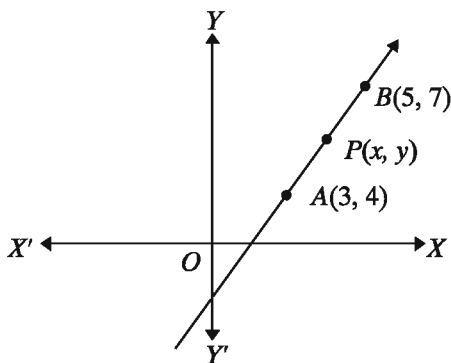

again, slope of PB , $m_3 = \frac{7-y}{5-x} \dots (4)$

As slopes of AB and PB are same,

$$m_1 = m_3$$

$$\text{or, } \frac{3}{2} = \frac{7-y}{5-x} \text{ [From (1) and (4)]}$$

$$\text{or, } 15 - 3x = 14 - 2y$$

$$\text{or, } 2y + 15 = 3x + 14$$

$$\text{or, } 2y = 3x - 1$$

$$\text{or, } y = \frac{3}{2}x - \frac{1}{2} \dots (5)$$

The equation (3) and (5) is the same equation. So, the equation (3) or (5) is the Cartesian equation of the straight line L . If we observe, we will find that the equation (3) or (5) is the single equation of x and y and it indicates a straight line. So, undoubtedly it can be said that the single equation of x and y always indicates a straight line. The equations (3) and (5) can be expressed in the following way:

$$y = \frac{3}{2}x - \frac{1}{2}$$

$$\frac{y-4}{x-3} = \frac{3}{2} \text{ or } \frac{y-7}{x-5} = \frac{3}{2}$$

$$\text{i.e., } \frac{y-4}{x-3} = \frac{7-4}{5-3} \text{ or } \frac{y-7}{x-5} = \frac{7-4}{5-3}$$

$$\text{i.e., } \frac{y-4}{x-3} = m \text{ or } \frac{y-7}{x-5} = m$$

Therefore, it is said usually, if two definite points $A(x_1, y_1)$ and $B(x_2, y_2)$ lie on any straight line, the slope

$$m = \frac{y_2 - y_1}{x_2 - x_1} \left[\frac{\text{rise}}{\text{run}} \right] \left[\frac{\text{rise}}{\text{run}} \right]$$

and the Cartesian equation of that straight line will be:

$$\frac{y - y_1}{x - x_1} = m \dots (6), \quad \frac{y - y_2}{x - x_2} = m \dots (7)$$

From equation (6):

$$y - y_1 = m(x - x_1) \dots (8)$$

From equation (7):

$$y - y_2 = m(x - x_2) \dots (9)$$

\therefore From (8) and (9) we can say, if the slope of the line is m and the line passes through the definite points (x_1, y_1) and (x_2, y_2) , the Cartesian equation of the line will be determined by the equation (8) or (9). From the equation (6) and (7) we get,

$$m = \frac{y - y_1}{x - x_1} = \frac{y - y_2}{x - x_2} \dots (10)$$

From the equation (10), it is said clearly, if a straight line passes through two definite points $A(x_1, y_1)$ and $B(x_2, y_2)$, its Cartesian equation will be

$$\frac{y - y_1}{x - x_1} = \frac{y_1 - y_2}{x_1 - x_2} \text{ or } \frac{y - y_2}{x - x_2} = \frac{y_2 - y_1}{x_2 - x_1} \dots (11)$$

$$\text{As, } m = \frac{y_1 - y_2}{x_1 - x_2} = \frac{y_2 - y_1}{x_2 - x_1}$$

The above discussion is explained with the help of the following examples so that the students can easily understand the slope of the straight line and the equation.

Example 20. Find the equation of the straight line connecting the points $A(3, 4)$ and $B(6, 7)$.

$$\text{Solution: Slope of } AB, m = \frac{\text{rise}}{\text{run}} = \frac{7 - 4}{6 - 3} = \frac{3}{3} = 1$$

By applying the equation (8), the equation of the line AB is, $y - 4 = 1(x - 3)$

$$\text{or, } y - 4 = x - 3$$

$$\text{or, } y = x + 1$$

By applying the equation (9), the equation of the line AB is, $y - 7 = 1(x - 6)$

$$\text{or, } y = x + 1$$

By applying the equation (11), the equation of the line AB is $\frac{y - 4}{x - 3} = \frac{4 - 7}{3 - 6}$

$$\text{or, } \frac{y - 4}{x - 3} = \frac{-3}{-3} = 1$$

$$\text{or, } y - 4 = x - 3$$

$$\text{or, } y = x + 1$$

Observe that, by applying any one of the formula (8) or (9) or (11), the equation of the straight line connecting two definite points can be determined. The learners can use either one according to their convenience.

Example 21. The slope of a definite straight line is 3 and the connecting point of the line is $(-2, -3)$. Find the equation of the line.

Solution: Given that, slope $m = 3$ and the definite point $(x_1, y_1) = (-2, -3)$

\therefore The equation of the line, $y - y_1 = m(x - x_1)$

$$\text{or, } y - (-3) = 3\{x - (-2)\}$$

$$\text{or, } y + 3 = 3(x + 2)$$

$$\text{or, } y = 3x + 3$$

\therefore Required equation, $y = 3x + 3$

Example 22. The straight line $y = 3x + 3$ passes through the point $P(t, 4)$. Find the coordinate of P . The line intersects the x -axis and the y -axis on the points A and B respectively. Find the coordinates of the points A and B .

Solution: The point $P(t, 4)$ lies on the line $y = 3x + 3$; so coordinates of P will satisfy the equation of the line.

$$\text{So, } 4 = 3 \cdot t + 3$$

$$\text{or, } 3t = 4 - 3$$

$$\text{or, } t = \frac{1}{3}$$

\therefore The coordinate of P is $(t, 4) = P\left(\frac{1}{3}, 4\right)$

The line $y = 3x + 3$ intersects the x -axis at A . So, the ordinate or y coordinate of the point A is 0. [Since y is 0 on all points of the x -axis.]

$$\text{or, } 0 = 3x + 3 \text{ or, } x = -1$$

\therefore coordinate of A is $(-1, 0)$

Again, the line $y = 3x + 3$ intersects the y -axis at B . So, the abscissa or x coordinate of the point B is 0. [Since x is 0 on all points of the y -axis.]

$$\text{So, } y = 3 \cdot 0 + 3 \text{ or, } y = 3$$

\therefore Coordinate of B is $(0, 3)$

Now, draw the line AB on the Cartesian plane. The line AB intersects the x -axis at the point $(-1, 0)$ and the y -axis at the point $(0, 3)$. i.e., when the value of x is -1 , the line $y = 3x + 3$ intersects the x -axis. Again, when the value of y is 3, the line intersects the y -axis. So, the bisector x of the line is -1 and bisector y is 3.

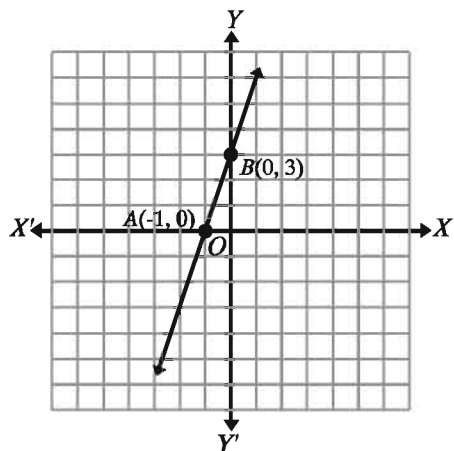

The general equation of such straight line which is not vertical can be expressed in the following way.

$$y = mx + c$$

Here, the slope of the line is m and c is the bisector of the y -axis. For $m > 0$ and $c > 0$ of the line is shown in the first figure.

Again, parallel to the y -axis, i.e., the general equation of the perpendicular line on the x -axis is $x = a$. In the same way, parallel to the x -axis, i.e., the general equation of the perpendicular line on the y -axis is $y = b$. See the first figure.

Observed, as the value of c is positive, the line $y = mx + c$ intersects c to the positive side of the y -axis at a single distance. As the value of m ($m = \tan\theta > 0$) is positive, the angle produced by the line $y = mx + c$ is an acute angle. As the values of a and b are positive, the line $x = a$ has been on the right side of the y -axis and the line $y = b$ has been shown above the x -axis.

In the case of the negative values of a, b and c , the position of the lines are shown in the second figure.

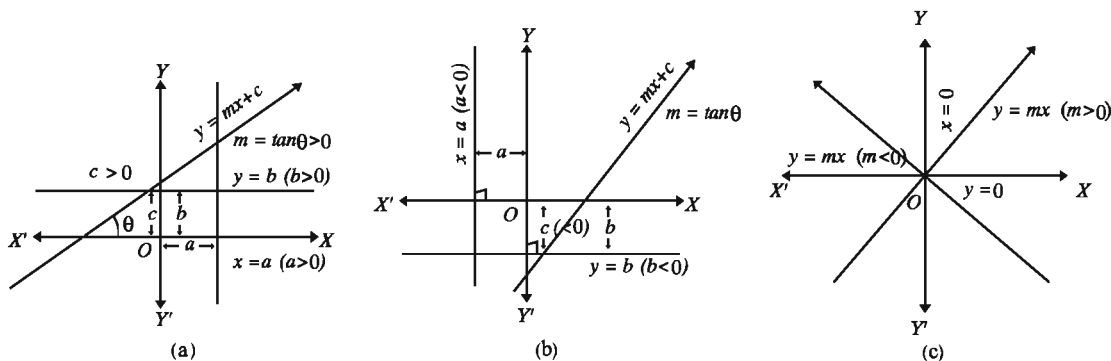

From first two figures and above discussion, we can say clearly, if $c = 0$, the line $y = mx$ will pass through the origin $(0, 0)$ and if $a = 0$, the line will pass through y -axis and if $b = 0$, it will pass through x -axis.

Example 23. Find the slope and the intersector of the straight line $y - 2x + 3 = 0$. Draw the line on the Cartesian plane.

Solution: $y - 2x + 3 = 0$

or, $y = 2x - 3$ [shape of $y = mx + c$]

\therefore Slope, $m = 2$ and Intersector of y -axis is $c = -3$

Now, if the line intersects the x -axis and the y -axis at A and B , we get,

The coordinates of the point A is $\left(\frac{3}{2}, 0\right)$

[Putting in x -axis $y = 0$ $x = \frac{3}{2}$]

The coordinates of the point B is $(0, -3)$

[Putting $x = 0$ in y -axis, we get $y = -3$]

The line is drawn on the Cartesian plane.

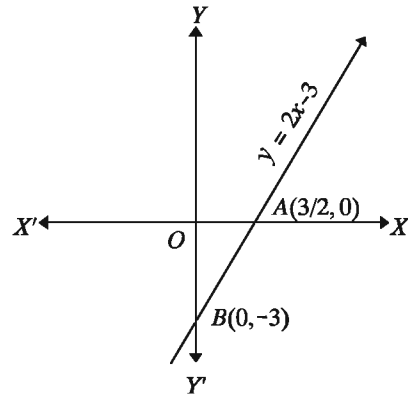

Example 24. The line joining the points $A(-1, 3)$ and $B(5, 15)$ intersects the x -axis and the y -axis at the points P and Q respectively. Find the equation of the line PQ and the length of PQ .

Solution: The equation of the line AB ,

$$\begin{aligned} \frac{y - 3}{x + 1} &= \frac{3 - 15}{-1 - 5} \\ &= \frac{-12}{-6} = 2 \end{aligned}$$

or, $y - 3 = 2x + 2$

or, $y = 2x + 5 \dots (1)$

From (1), the coordinate of P is $\left(-\frac{5}{2}, 0\right)$

and the coordinate of Q is $(0, 5)$

\therefore the equation of the line PQ ,

$$\frac{y - 0}{x + \frac{5}{2}} = \frac{0 - 5}{\frac{-5}{2} - 0}$$

$$\text{or, } \frac{2y}{2x + 5} = \frac{10}{5} = \frac{2}{1}$$

$$\text{or, } 2y = 4x + 10$$

$$\text{or, } y = 2x + 5$$

Remark: AB and PQ are the same straight line.

Now, $\frac{\text{length of } PQ}{\sqrt{\left(-\frac{5}{2} - 0\right)^2 + (0 - 5)^2}} =$

$$= \sqrt{\frac{25}{4} + 25} = \sqrt{\frac{125}{4}} = \frac{5\sqrt{5}}{2} \text{ unit}$$

Example 25. $A(3, 4)$, $B(-4, 2)$, $C(6, -1)$ and $D(k, 3)$ points rotate anti-clockwise.

- 1) Show that the connecting straight line between points A and B form an acute angle with x -axis.
- 2) If $P(x, y)$ point is equidistant from A and B then show that, $14x + 4y = 5$
- 3) Determine the value of k if the area of quadrilateral $ABCD$ is thrice that of $\triangle ABC$.

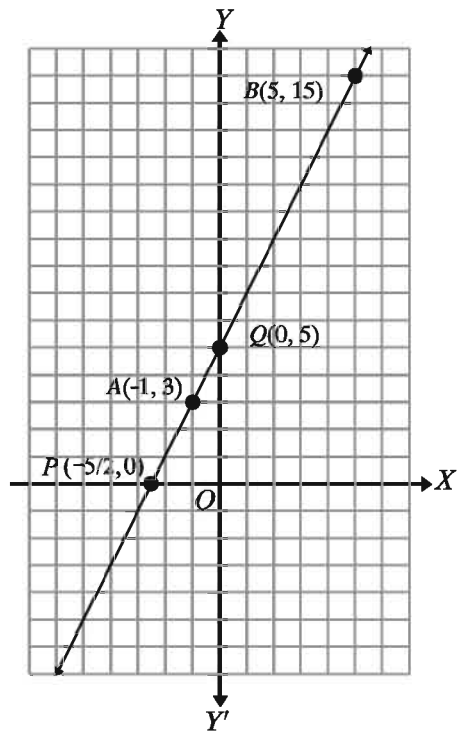

Solution:

- 1) If the slope of
- AB
- is
- m
- ,

$$m = \frac{2-4}{-4-3} = \frac{-2}{-7} = \frac{2}{7}$$

As the slope is positive, the line forms acute angle with positive x -axis.

- 2)
- $PA = \sqrt{(x-3)^2 + (y-4)^2}$
- and
- $PB = \sqrt{(x+4)^2 + (y-2)^2}$

As P is equidistant from A and B , $PA = PB$

$$\therefore \sqrt{(x-3)^2 + (y-4)^2} = \sqrt{(x+4)^2 + (y-2)^2}$$

$$\text{or, } x^2 - 6x + 9 + y^2 - 8y + 16 = x^2 + 8x + 16 + y^2 - 4y + 4$$

$$\text{or, } -6x - 8y - 8x + 4y = 20 - 25$$

$$\text{or, } -14x - 4y = -5$$

$$\therefore 14x + 4y = 5$$

- 3) Area of quadrilateral
- $ABCD = \frac{1}{2} \begin{vmatrix} 3 & -4 & 6 & k & 3 \\ 4 & 2 & -1 & 3 & 4 \end{vmatrix}$

$$= \frac{1}{2} \{6 + 4 + 18 + 4k - (-16 + 12 - k + 9)\} = \frac{1}{2} (28 + 4k - 5 + k) = \frac{1}{2} (23 + 5k)$$

$$\text{Area of triangle } ABC = \frac{1}{2} \begin{vmatrix} 3 & -4 & 6 & 3 \\ 4 & 2 & -1 & 4 \end{vmatrix}$$

$$= \frac{1}{2} \{6 + 4 + 24 - (-16 + 12 - 3)\} = \frac{41}{2}$$

$$\text{According to the question, } \frac{1}{2} (23 + 5k) = 3 \times \frac{41}{2}$$

$$\text{or, } 23 + 5k = 123$$

$$\text{or, } 5k = 100 \text{ or, } k = 20$$

$$\therefore k = 20$$

Exercise 11.4

1. If
- $A(-1, 3)$
- and
- $B(2, 5)$
- then,
- AB
- 's

(i) length is $\sqrt{13}$ unit

(ii) slope is $\frac{2}{3}$

(iii) equation is $2x - 3y = 11$

Which of the followings is true?

- 1) i, ii 2) i, iii 3) ii, iii 4) i, ii and iii
2. In $\sqrt{s(s-a)(s-b)(s-c)}$, s means
- 1) area of triangle 2) area of circle
- 3) half perimeter of triangle 4) half perimeter of circle.
- 3.

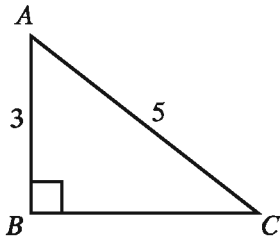

Area of the triangle is

- 1) 12 square unit 2) 15 square unit 3) 6 square unit 4) 60 square unit
- 4.
-
- Slope of the line AB
- 1) 2 2) -2 3) 0 4) 6
5. Product of the slopes of $x - 2y - 10 = 0$ and $2x + y - 3 = 0$ is
- 1) -2 2) 2 3) -3 4) -1
6. Equations $y = \frac{x}{2} + 2$ and $5x - 10y + 20 = 0$ indicate
- 1) two different lines 2) the same line
- 3) that the two lines are parallel 4) that the two lines intersect each other
7. The intersecting point of $y = x - 3$ and $y = -x + 3$ is
- 1) (0, 0) 2) (0, 3) 3) (3, 0) 4) (-3, 3)
8. $x = 1, y = 1$. The coordinate of the point on which the two lines intersect x-axis is

- 1) $(0, 1)$ 2) $(1, 0)$ 3) $(0, 0)$ 4) $(1, 1)$
9. $x = 1, y = 1$. The area of the region created by the two lines with the two axes is
- 1) $\frac{1}{2}$ square unit 2) 1 square unit
3) 2 square unit 4) 4 square unit
10. Find the equation of the straight line which passes through the point $(2, -1)$ and whose slope is 2.
11. Find the equation of the straight line passing through each pair of points below:
- 1) $A(1, 5), B(2, 4)$ 2) $A(3, 0), B(0, -3)$
3) $A(a, 0), B(2a, 3a)$
12. In each case given below, find the equation of the straight line
- 1) Slope is 3 and intersector of y is 5
2) Slope is 3 and intersector of y is -5
3) Slope is -3 and intersector of y is 5
4) Slope is -3 and intersector of y is -5
- Draw these four straight lines on the same plane. [By these lines it will be understood in which quadrant the slope and the symbol indicating bisector will remain]
13. Find the points where each of the following straight lines intersects the x -axis and the y -axis. Also draw the lines.
- 1) $y = 3x - 3$ 2) $2y = 5x + 6$
3) $3x - 2y - 4 = 0$
14. Find the equation of the straight line passing through the point $(k, 0)$ and having slope k using k . Find k if the line passes through the point $(5, 6)$.
15. Find the equation of the straight line passing through the point $(k^2, 2k)$ and having slope $\frac{1}{k}$. If the line passes through the point $(-2, 1)$, find the possible value of k .
16. A straight line with slope $\frac{1}{2}$ passes through the point $A(-2, 3)$. If the line passes through the point $(3, k)$, what is the value of k ?
17. A line with slope 3 passes through the point $A(-1, 6)$ and intersects x -axis at the point B . Another line passing through the point A intersects x -axis at the point $C(2, 0)$.

- 1) Find the equations of the lines AB and AC .
 - 2) Find the area of $\triangle ABC$.
18. Show that the two lines $y - 2x + 4 = 0$ and $3y = 6x + 10$ do not intersect each other. By drawing the two lines, explain why the equation have no solution.
19. The three equations $y = x + 5$, $y = -x + 5$, and $y = 2$ indicate the three sides of a triangle. Draw the triangle and find the area.
20. Find the coordinate of the intersecting point of the two lines $y = 3x + 4$ and $3x + y = 10$. Draw the two lines and find the area of the triangle with x -axis.
21. Prove that the three lines $2y - x = 2$, $y + x = 7$ and $y = 2x - 5$ are concurrent, i.e., the lines pass through the same point.
22. $y = x + 3$, $y = x - 3$, $y = -x + 3$ and $y = -x - 3$ indicate the four sides of a quadrilateral. Draw the quadrilateral and determine the area in three different methods.
23. $A(-4, 13)$, $B(8, 8)$, $C(13, -4)$ and $D(1, 1)$ are the vertices of a quadrilateral.
- 1) Determine the angle that line BD forms with x -axis.
 - 2) Determine the characteristic of quadrilateral $ABCD$.
 - 3) Determine the area of that portion of quadrilateral $ABCD$ which forms a triangle with x -axis.
24. Four corner points of a quadrilateral are $P(5, 2)$, $Q(-3, 2)$, $R(4, -1)$ and $S(-2, -1)$
- 1) Determine the equation of straight line PS .
 - 2) Determine the length of the diagonal of the square that has the same area as that of quadrilateral $PQSR$.
 - 3) Determine the area of that portion of quadrilateral $PQSR$ which resides in the second quadrant.

Chapter 12

Planar Vector

In physics, we have learnt about two types of quantities. One type is denoted only by the magnitude [quantity being measured by using addition (+) or subtraction (−) signs]. The other type requires both magnitude and direction. The first one is known as scalar and the second as vector. We shall discuss about vector quantities in this chapter.

At the end of this chapter, the students will be able to-

- ▶ describe scalar and vector quantities;
- ▶ explain scalar and vector quantities with symbols;
- ▶ explain equal vector, opposite vector and position vector;
- ▶ explain vector addition and rules of vector addition;
- ▶ explain the subtraction of vectors;
- ▶ explain the scalar multiple of vectors and a unit vector;
- ▶ explain the scalar multiple of vectors and the distributive law;
- ▶ solve different geometrical problems using vectors.

Scalar and Vector Quantities

Measurement of things is necessary in all spheres of our daily life. Length of a body, measure of time, amount of money, measurement of volume and temperature can be denoted by 5 cm., 3 minutes, 12 taka, 5 litres and 6° C, respectively. For these measurements, it is sufficient to state those quantities with their respective units. Again, if it is stated that a man starting from a point first travels 4 metres and then 5 metres; then to determine his distance from the starting point, it is necessary to know the direction of his motion. It is not possible to determine correctly how far the man has moved from the starting point unless the exact direction of the motion is known.

The quantity which is completely described by its magnitude with a unit or + or − signs before magnitude is a **Scalar Quantity**. Length, mass, speed, temperature

etc. are scalar quantities.

The quantity which, for its complete description, requires magnitude as well as direction is a **Vector Quantity**. Displacement, velocity, acceleration, weight, force etc. are vector quantities.

Geometrical interpretation of a vector: directed line segment

If one end of a straight line is termed as the **initial point** and the other end as the **terminal point** then the straight line is called a **directed line segment**. The directed line segment whose initial point is A and terminal point is B is denoted by \overrightarrow{AB} . Each directed line segment is a vector quantity whose measurement is the length of the line segment (represented by $(|\overrightarrow{AB}|)$ or shortly AB) and whose direction is along the line AB straight from A to B .

Conversely, any vector quantity can be expressed by a directed line segment where the length of the line segment is the measurement of the vector quantity and the direction represented from initial point to terminal point is the direction of the vector. Hence, vector quantity and directed line segment are the same. Directed line segments are also called **Geometric Vectors**. Our discussion will be limited to the vectors in a plane. By vector we shall mean Geometric Vectors.

Any vector (directed line segment) which is a part of an unending straight line is called the **support line** or just **support** of the vector.

Usually a vector is represented by a letter e.g. $\underline{u} = \overrightarrow{AB}$. To denote a vector, the vector is underscored and its directive line segment is adorned with a \rightarrow above. $\underline{u} = \overrightarrow{AB}$ means the initial point of the vector \underline{u} is A and terminal point is B ; its direction is from A to B and its length $|\underline{u}| = |\overrightarrow{AB}|$ is the length of the line segment AB .

Activity:

- 1) The school is situated 3 kilometres to the south of your home. What is your velocity if you require 1 hour to go to the school from your home on foot?
- 2) What is your velocity if you come home by a bicycle in 20 minutes after the school breaks?

Equivalence of vectors and Opposite vector

Equal vector: A vector \underline{u} is said to be equal to another vector \underline{v} if

- 1) $|\underline{u}| = |\underline{v}|$ (Length of \underline{u} is equal to length of \underline{v})
- 2) Supports of \underline{u} and \underline{v} are same or parallel.
- 3) Directions of \underline{u} and \underline{v} are same.

$$\begin{array}{ccc}
 A \xrightarrow{\underline{u}} B & C \xrightarrow{\underline{v}} D & C \xrightarrow{\underline{v}} D \\
 & & A \xrightarrow{\underline{u}} B
 \end{array}$$

It is easily understood that the definition of equivalence abides by the following rules:

- 1) $\underline{u} = \underline{u}$
- 2) If $\underline{u} = \underline{v}$, $\underline{v} = \underline{u}$
- 3) If $\underline{u} = \underline{v}$ and $\underline{v} = \underline{w}$, $\underline{u} = \underline{w}$

If the support lines of \underline{u} and \underline{v} are same or parallel then we call briefly \underline{u} and \underline{v} are parallel.

Note: A vector can be drawn at any point which is equal to a given vector. Because if a point P and a vector \underline{u} are given, we draw a straight line at the point P which is parallel to support line of \underline{u} . Now we take PQ line segment to the direction of \underline{u} and equal to $|\underline{u}|$. Then according to the construction, $\overrightarrow{PQ} = \underline{u}$.

Opposite vector: \underline{v} is called the opposite vector of \underline{u} if

- 1) $|\underline{v}| = |\underline{u}|$
- 2) Lines of support of \underline{u} and \underline{v} are the same and parallel.
- 3) The direction of \underline{v} is opposite of that of \underline{u}

If \underline{v} is an opposite vector of \underline{u} then \underline{u} is also opposite of \underline{v} . It is clear from the definition of equality that if both \underline{v} then \underline{w} be the opposite vectors of \underline{u} then $\underline{v} = \underline{w}$. $-\underline{u}$ is the opposite vector of \underline{u} . If $\underline{u} = \overrightarrow{AB}$ then $-\underline{u} = \overrightarrow{BA}$.

Addition of Vectors

If from the terminal point of a vector \underline{u} another vector \underline{v} is drawn, then $\underline{u} + \underline{v}$ denotes such a vector whose initial point is the initial point of \underline{u} and terminal point is the terminal point of \underline{v} .

Let $\overrightarrow{AB} = \underline{u}$, $\overrightarrow{BC} = \underline{v}$ be two vectors such that the terminal point of \underline{u} is the initial point of \underline{v} then the vector \overrightarrow{AC} joining the initial point of \underline{u} and the terminal point of \underline{v} is called the sum of the vectors \underline{u} and \underline{v} and is denoted by $\underline{u} + \underline{v}$

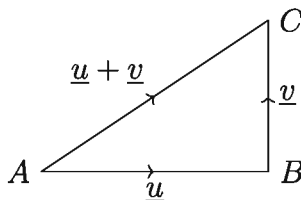

Triangle law of addition of vectors: In the above diagram, if \underline{u} and \underline{v} are not parallel to each other then \underline{u} , \underline{v} and $\underline{u} + \underline{v}$ vectors form a triangle; hence, this addition system is called triangle law.

As a corollary to the triangle law of addition of vectors parallelogram law of addition of vectors is as follows:

Parallelogram law of addition of vectors: If the magnitude and direction of two vectors \underline{u} and \underline{v} are denoted by the two adjacent sides of a parallelogram then the magnitude and direction of $\underline{u} + \underline{v}$ is denoted by that diagonal of the parallelogram which passes through the point of intersection of the lines denoting the two vectors. We shall prove it now.

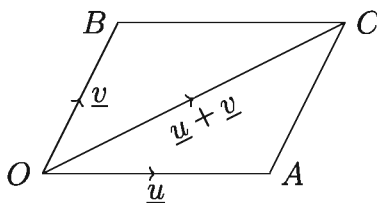

Proof: Let \overrightarrow{OA} and \overrightarrow{OB} denote the vectors \underline{u} and \underline{v} drawn from any point O . Draw the parallelogram $OACB$ and its diagonal \overrightarrow{OC} . Then the diagonal \overrightarrow{OC} of the parallelogram will denote the sum of \underline{u} and \underline{v} , i.e. $\overrightarrow{OC} = \underline{u} + \underline{v}$.

In the parallelogram $OACB$, we have OB and AC equal and parallel. $\therefore \overrightarrow{AC} = \overrightarrow{OB} = \underline{v}$ [by transfer of vectors]

\therefore Using triangle law, $\underline{u} + \underline{v} = \overrightarrow{OA} + \overrightarrow{OB} = \overrightarrow{OA} + \overrightarrow{AC} = \overrightarrow{OC}$ [Proved]

Note: 1) The sum of two or more vectors is also said to be their **resultant**. The method of addition of vectors is followed in determining the resultant of forces or velocities. 2) If the two vectors are parallel, the parallelogram law is not applicable to their addition but the triangle law is applicable in all the cases.

Subtraction of vectors

The subtraction of the vectors \underline{u} and \underline{v} is $\underline{u} - \underline{v}$ and it is equivalent to the addition of \underline{u} and $-\underline{v}$ (opposite vector of \underline{v}) i.e. $\underline{u} + (-\underline{v})$.

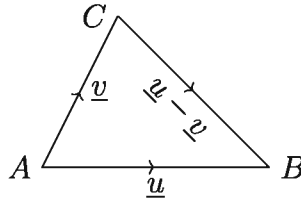

Triangle law of subtraction of vectors: If the initial points of \underline{u} and \underline{v} are same then initial point of $\underline{u} - \underline{v}$ will be the same as the final point of \underline{v} and the final point of $\underline{u} - \underline{v}$ will be the same as the final point of \underline{u} . In short, the difference of two vectors with same initial point is the opposite vector formed by the initial points. Therefore, if $\underline{u} = \overrightarrow{AB}$, $\underline{v} = \overrightarrow{AC}$ then $\underline{u} - \underline{v} = \overrightarrow{CB}$, i.e. $\overrightarrow{AB} - \overrightarrow{AC} = \overrightarrow{CB}$. We shall prove it now.

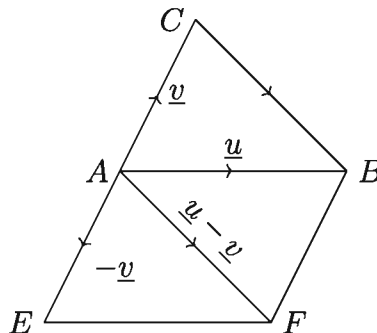

Proof: Line segment CA is produced such that $AE = CA$, parallelogram $AEFB$ is drawn. According to the parallelogram law of additions of vectors, $\overrightarrow{AE} + \overrightarrow{AB} = \overrightarrow{AF}$.

Again $AFBC$ is a parallelogram, as $BF = AE = CA$ and since $BF \parallel AE$, then $BF \parallel CA$.

$\therefore \overrightarrow{AF} = \overrightarrow{CB}$ (by transfer of vector), but $\overrightarrow{AE} = -\underline{v}$ and $\overrightarrow{AB} = \underline{u}$

Therefore $\underline{u} - \underline{v} = \overrightarrow{CB}$ is proved.

Zero Vector

A vector whose absolute value is zero and whose direction cannot be determined is called a zero vector.

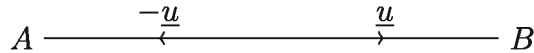

If \underline{u} is any vector, then what is the value of $\underline{u} + (-\underline{u})$?

Let $\underline{u} = \overrightarrow{AB}$ then $-\underline{u} = \overrightarrow{BA}$.

Hence, $\underline{u} - \underline{u} = \overrightarrow{AB} + \overrightarrow{BA} = \overrightarrow{AA}$ [by triangle law]

But what kind of vector is \overrightarrow{AA} ? Its initial point and final point are same. Hence its length is zero. i.e. \overrightarrow{AA} is to be understood as the point A . This kind of vector (whose length is zero) is called zero vector and denoted by the symbol $\underline{0}$. This is the only vector which has no fixed direction and support line.

For the introduction of zero vector we can say that $\underline{u} + (-\underline{u}) = \underline{0}$ and $\underline{u} + \underline{0} = \underline{0} + \underline{u} = \underline{u}$

Virtually trial identity is involved with zero vector.

Laws of Vector Addition

Just like arithmetical addition, in vector addition commutative, associative and cancellation law can be used.

Commutative law: For any two vectors \underline{u} , \underline{v} , we get $\underline{u} + \underline{v} = \underline{v} + \underline{u}$

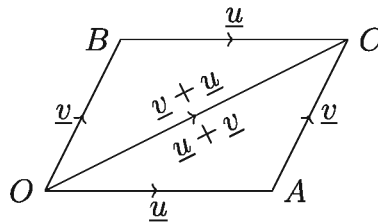

Proof: Let $\overrightarrow{OA} = \underline{u}$ and $\overrightarrow{OB} = \underline{v}$. Draw the parallelogram $OACB$ and its diagonal OC . OA and BC are equal and parallel. Also OB and AC are equal and parallel.

$\therefore \overrightarrow{OC} = \overrightarrow{OA} + \overrightarrow{AC} = \underline{u} + \underline{v}$; again, $\overrightarrow{OC} = \overrightarrow{OB} + \overrightarrow{BC} = \underline{v} + \underline{u}$

$\therefore \underline{u} + \underline{v} = \underline{v} + \underline{u}$ Therefore, addition of vectors obeys the commutative law.

Associative law of addition of vectors: For any three vectors \underline{u} , \underline{v} , \underline{w} we have

$$(\underline{u} + \underline{v}) + \underline{w} = \underline{u} + (\underline{v} + \underline{w})$$

Proof: Let, $\overrightarrow{OA} = \underline{u}$, $\overrightarrow{AB} = \underline{v}$, $\overrightarrow{BC} = \underline{w}$, i.e. \underline{v} is drawn from the terminal of \underline{u} and \underline{w} is drawn from the terminal point of \underline{v} . Join O , C and A , C .

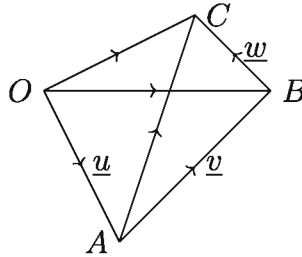

Then $(\underline{u} + \underline{v}) + \underline{w} = (\overrightarrow{OA} + \overrightarrow{AB}) + \overrightarrow{BC} = \overrightarrow{OB} + \overrightarrow{BC} = \overrightarrow{OC}$

Again, $\underline{u} + (\underline{v} + \underline{w}) = \overrightarrow{OA} + (\overrightarrow{AB} + \overrightarrow{BC}) = \overrightarrow{OA} + \overrightarrow{AC} = \overrightarrow{OC}$

$\therefore (\underline{u} + \underline{v}) + \underline{w} = \underline{u} + (\underline{v} + \underline{w})$; Hence vector addition obeys associative law.

Corollary 1. The sum of three vectors represented by the three sides of a triangle taken in the same order is zero. In the diagram above, $\overrightarrow{OB} + \overrightarrow{BA} + \overrightarrow{AO} = \overrightarrow{OA} + \overrightarrow{AO} = -\overrightarrow{AO} + \overrightarrow{AO} = \underline{0}$

Cancellation law of addition of vector: For any three vectors \underline{u} , \underline{v} , \underline{w} , if $\underline{u} + \underline{v} = \underline{u} + \underline{w}$ then, $\underline{v} = \underline{w}$

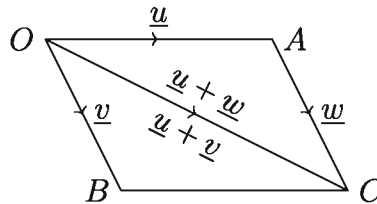

Proof: As $\underline{u} + \underline{v} = \underline{u} + \underline{w}$

$\therefore \underline{u} + \underline{v} + (-\underline{u}) = \underline{u} + \underline{w} + (-\underline{u})$ [Adding $-\underline{u}$ in both sides]

or, $\underline{u} - \underline{u} + \underline{v} = \underline{u} - \underline{u} + \underline{w}$ i.e. $\underline{v} = \underline{w}$

Scalar multiple of a vector

If \underline{u} is any vector and m is any real number, then what is understood by $m\underline{u}$ is explained here now.

1. If $m = 0$ then, $m\underline{u} = \underline{0}$ or zero vector
2. If $m \neq 0$ then, the length of $m\underline{u}$ is equal to $|m|$ times that of \underline{u} and the supports of $m\underline{u}$ are same as that of \underline{u} 's. And,
 - 1) If $m > 0$, then direction of $m\underline{u}$ and that of \underline{u} are same.
 - 2) If $m < 0$, then direction of $m\underline{u}$ and that of \underline{u} are opposite.

Note: 1) if $m = 0$ or $\underline{u} = \underline{0}$, then $m\underline{u} = \underline{0}$ 2) $1\underline{u} = \underline{u}$, $(-1)\underline{u} = -\underline{u}$

From the above definition, it is observed that, $m(n\underline{u}) = n(m\underline{u}) = (mn)(\underline{u})$

Both $m, n > 0$, both < 0 , any one > 0 and the other < 0 , any one or both is zero -after considering all these case separately, the reality of the rule can be established. An Example of such cases is given below

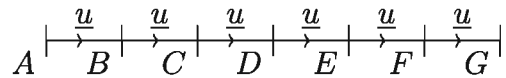

Suppose, $\overrightarrow{AB} = \overrightarrow{BC} = \underline{u}$

AC is produced up to G , such that $CD = DE = EF = FG = AB$.

Then $\overrightarrow{AG} = \overrightarrow{AB} + \overrightarrow{BC} + \overrightarrow{CD} + \overrightarrow{DE} + \overrightarrow{EF} + \overrightarrow{FG} = \underline{u} + \underline{u} + \underline{u} + \underline{u} + \underline{u} + \underline{u} = 6\underline{u}$

Again, $\overrightarrow{AG} = \overrightarrow{AC} + \overrightarrow{CE} + \overrightarrow{EG} = 2\underline{u} + 2\underline{u} + 2\underline{u} = 3(2\underline{u})$

And $\overrightarrow{AG} = \overrightarrow{AD} + \overrightarrow{DG} = 3\underline{u} + 3\underline{u} = 2(3\underline{u})$

$\therefore 2(3\underline{u}) = 3(2\underline{u}) = 2 \times 3(\underline{u})$

Note: If the support lines of two vectors are alike or parallel, then one can be expressed as scalar multiple of the other.

In reality, if $AB \parallel CD$ then, $\overrightarrow{AB} = m\overrightarrow{CD}$ where, $|m| = \frac{|\overrightarrow{AB}|}{|\overrightarrow{CD}|} = \frac{AB}{CD}$

- 1) if $m > 0$, \overrightarrow{AB} and \overrightarrow{CD} are alike in direction,
- 2) if $m < 0$, \overrightarrow{AB} and \overrightarrow{CD} are unlike in direction,

Distribution laws concerning scalar multiples of vectors

If m, n are two scalars and \underline{u} and \underline{v} are two vectors then

1. $(m + n)\underline{u} = m\underline{u} + n\underline{u}$
2. $m(\underline{u} + \underline{v}) = m\underline{u} + m\underline{v}$

Formula 1. $(m + n)\underline{u} = m\underline{u} + n\underline{u}$

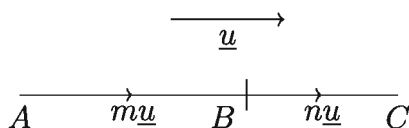

Proof: If m or n is zero, then the law is obviously true.

Suppose both m and n are both positive and $\overrightarrow{AB} = m\underline{u}$ $\therefore |\overrightarrow{AB}| = m|\underline{u}|$

AB is produced up to C so that $|\overrightarrow{BC}| = n|\underline{u}| \quad \therefore \overrightarrow{BC} = n\underline{u}$
 $|\overrightarrow{AC}| = |\overrightarrow{AB}| + |\overrightarrow{BC}| = m|\underline{u}| + n|\underline{u}| = (m+n)|\underline{u}| \quad \therefore \overrightarrow{AC} = (m+n)\underline{u}$
 But $\overrightarrow{AC} = \overrightarrow{AB} + \overrightarrow{BC} \quad \therefore m\underline{u} + n\underline{u} = (m+n)\underline{u}$

If both m, n are negative, then the length of $(m+n)\underline{u}$ is $|(m+n)||\underline{u}|$ and the direction will be opposite direction of \underline{u} , so the length of the vector $m\underline{u} + n\underline{u}$ will be $|m||\underline{u}| + |n||\underline{u}| = (|m| + |n|)|\underline{u}|$ and the direction will be opposite of \underline{u} . But, if $m < 0$ and $n < 0$ then, $|m| + |n| = |m+n|$. In that case, $(m+n)\underline{u} = m\underline{u} + n\underline{u}$.

Lastly, if among m and n , $m > 0$ and $n < 0$, then the length of $(m+n)\underline{u}$ will be $(|m| - |n|)|\underline{u}|$ and direction will be aligned with that of \underline{u} , when $|m| > |n|$ and opposite to direction of \underline{u} , then vector $m\underline{u} + n\underline{u}$ will be aligned in direction of $(m+n)\underline{u}$ and their lengths will be same.

Observation: Three points A, B, C will be co-linear if and only if \overrightarrow{AC} be a scalar multiple of \overrightarrow{AB}

Remark: 1) If the support lines of two vectors are alike or parallel and their directions are alike, then the vectors are called similar vectors . 2) The vector whose length is 1 unit is called a unit vector.

Formula 2. $m(\underline{u} + \underline{v}) = m\underline{u} + m\underline{v}$

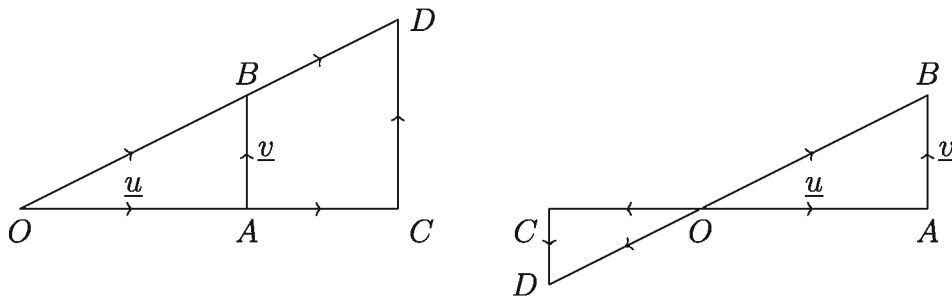

Proof: Let, $\overrightarrow{OA} = \underline{u}, \overrightarrow{AB} = \underline{v}$ then $\overrightarrow{OB} = \overrightarrow{OA} + \overrightarrow{AB} = \underline{u} + \underline{v}$

OA is produced to C such that $OC = m \cdot OA$, The straight line CD drawn at C and parallel to AB meets the produced OB at D . Since the triangles OAB and OCD are similar,

Hence, $\frac{|\overrightarrow{OC}|}{|\overrightarrow{OA}|} = \frac{|\overrightarrow{CD}|}{|\overrightarrow{AB}|} = \frac{|\overrightarrow{OD}|}{|\overrightarrow{OB}|} = m$

$\therefore OC = m \cdot OA, CD = m \cdot AB, OD = m \cdot OB$

$\therefore \overrightarrow{CD} = m\overrightarrow{AB} = m\underline{v}$

$$\text{here, } \overrightarrow{OC} + \overrightarrow{CD} = \overrightarrow{OD}$$

$$\text{or, } m(\overrightarrow{OA}) + m(\overrightarrow{AB}) = m(\overrightarrow{OB})$$

$$\therefore m\mathbf{u} + m\mathbf{v} = m(\mathbf{u} + \mathbf{v})$$

Observation: This formula is true for all values of m .

For ease of usage, the formulas related to Vectors are given below,

1. $\mathbf{u} + \mathbf{v} = \mathbf{v} + \mathbf{u}$
2. $(\mathbf{u} + \mathbf{v}) + \mathbf{w} = \mathbf{u} + (\mathbf{v} + \mathbf{w})$
3. $\mathbf{u} + \mathbf{0} = \mathbf{0} + \mathbf{u} = \mathbf{u}$
4. $\mathbf{u} + (-\mathbf{u}) = (-\mathbf{u}) + \mathbf{u} = \mathbf{0}$
5. if $\mathbf{u} + \mathbf{v} = \mathbf{u} + \mathbf{w}$ then $\mathbf{v} = \mathbf{w}$
6. $m(n\mathbf{u}) = n(m\mathbf{u}) = (mn)(\mathbf{u})$
7. $0\mathbf{u} = \mathbf{0}$
8. $1\mathbf{u} = \mathbf{u}$
9. $(-1)\mathbf{u} = -\mathbf{u}$
10. $(m + n)\mathbf{u} = m\mathbf{u} + n\mathbf{u}$

Activity: Verify the formula $(m + n)\mathbf{u} = m\mathbf{u} + n\mathbf{u}$ for the vector \mathbf{u} for different numerical values of m and n .

Position Vector

With respect to a given point O in a plane, the position of any point P in the plane can be fixed by \overrightarrow{OP} . \overrightarrow{OP} is called the position vector of P with respect to O and O is called the vector origin.

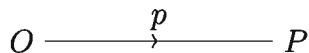

Let O be a fixed point in a plane and A is another point in the same plane. The vector \overrightarrow{OA} produced by joining O and A is called the position vector of A with respect to O . Similarly, \overrightarrow{OB} is the position vector of another point B in the same plane with respect to the same point O .

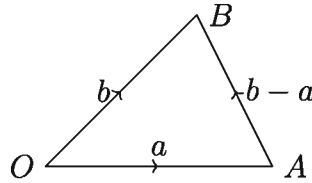

Join A, B ; Let, $\vec{OA} = \underline{a}, \vec{OB} = \underline{b}$

Then $\vec{OA} + \vec{AB} = \vec{OB}$ i.e. $\underline{a} + \vec{AB} = \underline{b}$

$\therefore \vec{AB} = \underline{b - a}$

Thus if the position vectors of two points are known, then the vector denoted by the line joining them can be obtained by subtracting the position vector of the initial point from that of the terminal point of the vector.

Observation: The position vector of a certain point may be different with respect to different vector origins. In solving a particular problem the position vector of all points of the problem are supposed with respect to the same origin.

Activity: Take a point O as origin on a page of your khatha. Then take another 5 points on it at different positions and draw their position vectors with respect to O .

Some Examples

Example 1. Show that,

- 1) $-(-\underline{a}) = \underline{a}$
- 2) $-m(\underline{a}) = m(-\underline{a}) = -(m\underline{a})$ where m is a scalar.
- 3) $\frac{1}{|\underline{a}|}\underline{a}$ is a unit vector whose direction is along that of \underline{a}

Solution:

- 1) According to opposite vector law, $\underline{a} + (-\underline{a}) = \underline{0}$
 again, $(-\underline{a}) + (-(-\underline{a})) = \underline{0}$
 $\therefore (-\underline{a}) + (-(-\underline{a})) = \underline{a} + (-\underline{a})$
 $\therefore (-(-\underline{a})) = \underline{a}$ [Cancellation law of vector addition]
- 2) $m\underline{a} + (-m)\underline{a} = [m + (-m)]\underline{a} = 0\underline{a} = \underline{0}$
 $\therefore (-m)\underline{a} = -m\underline{a} \dots \dots (1)$

$$\text{Again } m\underline{a} + m(-\underline{a}) = m[\underline{a} + (-\underline{a})] = m\underline{0} = \underline{0}$$

$$\therefore m(-\underline{a}) = -m\underline{a} \dots \dots (2)$$

$$\text{From (1) and (2), } (-m)\underline{a} = m(-\underline{a}) = -m\underline{a}$$

3) As $\underline{a} \neq \underline{0}$, so $|\underline{a}| \neq 0$

$$\text{Let, } \hat{a} = \frac{1}{|\underline{a}|}\underline{a}$$

Hence $|\hat{a}| = \frac{1}{|\underline{a}|}|\underline{a}| = 1$ and direction of \hat{a} and that of \underline{a} are same, so \hat{a} is a unit vector whose direction is along \underline{a} .

Example 2. $ABCD$ is a parallelogram whose diagonals are AC and BD .

- 1) Express the vectors \overrightarrow{AC} , \overrightarrow{BD} in terms of the vectors \overrightarrow{AB} and \overrightarrow{AD} .
- 2) Express the vectors \overrightarrow{AB} , \overrightarrow{AD} in terms of the vectors \overrightarrow{AC} and \overrightarrow{BD} .

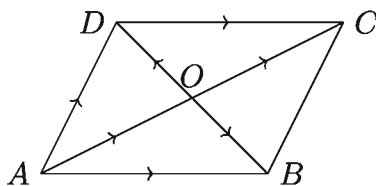

Solution:

$$1) \overrightarrow{AC} = \overrightarrow{AD} + \overrightarrow{DC} = \overrightarrow{AD} + \overrightarrow{AB}$$

$$\text{Again, } \overrightarrow{AB} + \overrightarrow{BD} = \overrightarrow{AD}, \overrightarrow{BD} = \overrightarrow{AD} - \overrightarrow{AB}$$

2) The diagonals of a parallelogram bisect each other. So,

$$\overrightarrow{AB} = \overrightarrow{AO} + \overrightarrow{OB} = \frac{1}{2}\overrightarrow{AC} + \frac{1}{2}\overrightarrow{DB} = \frac{1}{2}\overrightarrow{AC} - \frac{1}{2}\overrightarrow{BD}$$

$$\text{and } \overrightarrow{AD} = \overrightarrow{AO} + \overrightarrow{OD} = \frac{1}{2}\overrightarrow{AC} + \frac{1}{2}\overrightarrow{BD}$$

Example 3. With the help of vectors, prove that the line segment joining the middle points of two sides of a triangle is parallel to and half of the third side.

Solution: Let D and E be the middle points of the sides AB and AC of the triangle ABC . D and E are joined. It is required to prove that $DE \parallel BC$ and $DE = \frac{1}{2}BC$.

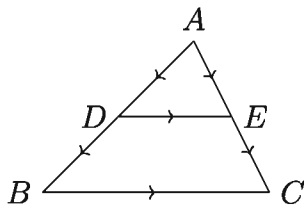

By the triangle law of subtraction of vectors, $\overrightarrow{AE} - \overrightarrow{AD} = \overrightarrow{DE}$ (1)

and $\overrightarrow{AC} - \overrightarrow{AB} = \overrightarrow{BC}$

but $\overrightarrow{AC} = 2\overrightarrow{AE}$, $\overrightarrow{AB} = 2\overrightarrow{AD}$ [\because D and E are respectively the middle points of AB and AC]

$\therefore \overrightarrow{AC} - \overrightarrow{AB} = \overrightarrow{BC}$

We get,

$2\overrightarrow{AE} - 2\overrightarrow{AD} = \overrightarrow{BC}$, i.e. $2(\overrightarrow{AE} - \overrightarrow{AD}) = \overrightarrow{BC}$

$\therefore 2\overrightarrow{DE} = \overrightarrow{BC}$ [from (1)]

$\therefore \overrightarrow{DE} = \frac{1}{2}\overrightarrow{BC}$

and $|\overrightarrow{DE}| = \frac{1}{2}|\overrightarrow{BC}|$ or $DE = \frac{1}{2}BC$

Therefore the lines of support of the vectors \overrightarrow{DE} and \overrightarrow{BC} are same or parallel. But \overrightarrow{DE} and \overrightarrow{BC} cannot be same. Hence the lines of support of the vectors \overrightarrow{DE} and \overrightarrow{BC} , i.e. the lines DE and BC are parallel.

Example 4. Prove that by Vector methods that the diagonals of a parallelogram bisect each other.

Solution: Let, the diagonals AC and BD of the parallelogram $ABCD$ intersect at O .

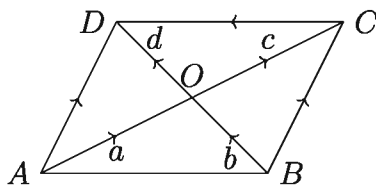

Suppose, $\overrightarrow{AO} = \underline{a}$, $\overrightarrow{BO} = \underline{b}$, $\overrightarrow{OC} = \underline{c}$, $\overrightarrow{OD} = \underline{d}$

It is required to prove that, $|\underline{a}| = |\underline{c}|$, $|\underline{b}| = |\underline{d}|$

$$\overrightarrow{AO} + \overrightarrow{OD} = \overrightarrow{AD} \text{ and } \overrightarrow{BO} + \overrightarrow{OC} = \overrightarrow{BC}$$

Since the opposite sides of a parallelogram are equal and parallel, $\overrightarrow{AD} = \overrightarrow{BC}$

$$\text{i.e. } \overrightarrow{AO} + \overrightarrow{OD} = \overrightarrow{BO} + \overrightarrow{OC}$$

$$\text{or, } \underline{a} + \underline{d} = \underline{b} + \underline{c}$$

$$\text{or, } \underline{a} - \underline{c} = \underline{b} - \underline{d} \text{ [adding } -c - d \text{ to both sides]}$$

here the support of \underline{a} and \underline{c} is AC , \therefore The support of $\underline{a} - \underline{c}$ is AC .

The support of \underline{b} and \underline{d} is BD , \therefore The support of $\underline{b} - \underline{d}$ is BD

If $\underline{a} - \underline{c}$ and $\underline{b} - \underline{d}$ are two equal and nonzero vectors, then their lines of support are same or parallel. But AC and BD are two intersecting straight lines which are not parallel. Hence $\underline{a} - \underline{c}$ and $\underline{b} - \underline{d}$ are zero vectors.

$$\therefore \underline{a} - \underline{c} = \underline{0} \text{ or } \underline{a} = \underline{c} \text{ and } \underline{b} - \underline{d} = \underline{0} \quad \underline{b} = \underline{d}$$

$$\therefore |\underline{a}| = |\underline{c}| \quad |\underline{b}| = |\underline{d}|$$

Therefore, the diagonals of a parallelogram bisect each other.

Example 5. Prove by vector method that the straight lines joining the middle points of the adjacent sides of a quadrilateral form of a parallelogram.

Solution: Let P, Q, R, S be the middle points of the sides of the quadrilateral $ABCD$. Join P and Q, Q and R, R and S, S and P . It is required to prove that $PQRS$ is a parallelogram.

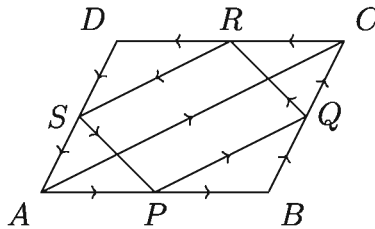

$$\text{Let, } \overrightarrow{AB} = \underline{a}, \overrightarrow{BC} = \underline{b}, \overrightarrow{CD} = \underline{c}, \overrightarrow{DA} = \underline{d}$$

$$\text{Then, } \overrightarrow{PQ} = \overrightarrow{PB} + \overrightarrow{BQ} = \frac{1}{2}\overrightarrow{AB} + \frac{1}{2}\overrightarrow{BC} = \frac{1}{2}(\underline{a} + \underline{b})$$

$$\text{Similarly, } \overrightarrow{QR} = \frac{1}{2}(\underline{b} + \underline{c}), \overrightarrow{RS} = \frac{1}{2}(\underline{c} + \underline{d}) \quad \overrightarrow{SP} = \frac{1}{2}(\underline{d} + \underline{a})$$

$$\text{But } (\underline{a} + \underline{b}) + (\underline{c} + \underline{d}) = \overrightarrow{AC} + \overrightarrow{CA} = \overrightarrow{AC} - \overrightarrow{AC} = \underline{0}$$

$$\text{i.e. } (\underline{a} + \underline{b}) = -(\underline{c} + \underline{d})$$

$$\therefore \overrightarrow{PQ} = \frac{1}{2}(\underline{a} + \underline{b}) = -\frac{1}{2}(\underline{c} + \underline{d}) = -\overrightarrow{RS} = \overrightarrow{SR}$$

$\therefore PQ$ and SR are equal and parallel.

Similarly, it can be proved that QR and PS are equal and parallel.

$\therefore PQRS$ is a parallelogram.

Exercises 12

1. if $AB \parallel DC$ then

(i) $\overrightarrow{AB} = m \cdot \overrightarrow{DC}$ where m is a scalar quantity

(ii) $\overrightarrow{AB} = \overrightarrow{DC}$

(iii) $\overrightarrow{AB} = \overrightarrow{CD}$

Which one of the above sentences is true?

1) i

2) ii

3) i and ii

4) i, ii and iii

2. If the two vectors are parallel

(i) Parallelogram law is applicable in case of their addition

(ii) Triangle law is applicable in case of their addition

(iii) Their lengths are always equal

Which one is true among the above sentences?

1) i

2) ii

3) i and ii

4) i, ii and iii

3. Which one of the following is true if $AB = CD$ and $AB \parallel CD$?

1) $\overrightarrow{AB} = \overrightarrow{CD}$

2) $\overrightarrow{AB} = m \cdot \overrightarrow{CD}$, where $m > 1$

3) $\overrightarrow{AB} + \overrightarrow{DC} < \underline{0}$

4) $\overrightarrow{AB} + m\overrightarrow{CD} = \underline{0}$, where $m > 1$

Answer the questions 4 and 5 on the basis of the information given below:

C is any point on the line segment AB and \underline{a} , \underline{b} and \underline{c} are respectively the position vectors of the points A , B and C with respect to a vector origin.

4. \overrightarrow{AA} vector is a –

(i) Point vector

(ii) Unit vector

(iii) Zero vector

Which one of these is right?

1) i, ii 2) i, iii 3) ii, iii 4) $i, ii, \text{ and } iii$ 5. Which one is true in case of $\triangle ABC$?

1) $\vec{AB} + \vec{BC} = \vec{CA}$

2) $\vec{AB} + \vec{AC} = \vec{BC}$

3) $\vec{CB} + \vec{BA} + \vec{CA} = \underline{0}$

4) $\vec{AB} + \vec{BC} + \vec{CA} = \underline{0}$

6. If the diagonals of parallelogram $ABCD$ are \vec{AC} and \vec{BD} then, express \vec{AB} and \vec{AC} through \vec{AD} and \vec{BD} and show that, $\vec{AC} + \vec{BD} = 2\vec{BC}$ and $\vec{AC} - \vec{BD} = 2\vec{AB}$.

7. Show that,

1) $-(\underline{a} + \underline{b}) = -\underline{a} - \underline{b}$

2) if $\underline{a} + \underline{b} = \underline{c}$ then $\underline{a} = \underline{c} - \underline{b}$

8. Show that,

1) $\underline{a} + \underline{a} = 2\underline{a}$

2) $(m - n)\underline{a} = m\underline{a} - n\underline{a}$

3) $m(\underline{a} - \underline{b}) = m\underline{a} - m\underline{b}$

9. Show that,

1) If each of $\underline{a}, \underline{b}$ is a nonzero vector, then $\underline{a} = m\underline{b}$ can be true if and only if, \underline{a} is parallel to \underline{b} .

2) If both $\underline{a}, \underline{b}$ are nonzero and non-parallel vectors, and if $m\underline{a} + n\underline{b} = \underline{0}$ then show that, $m = n = 0$.

10. If $\underline{a}, \underline{b}, \underline{c}, \underline{d}$ are the position vectors respectively of the points A, B, C, D then show that, $ABCD$ will be a parallelogram if and only if $\underline{b} - \underline{a} = \underline{c} - \underline{d}$.

11. Prove with the help of vectors that the straight line drawn from the middle point of a side of a triangle and parallel to another side passes through the middle point of the third side.

12. If the diagonals of a quadrilateral bisect each other, prove that it is a parallelogram.

13. Prove with the help of vectors that the straight line joining the middle points of the non-parallel sides of a trapezium is parallel to and half of the sum of the parallel sides.

14. Prove with the help of vectors that the straight line joining the middle points of the diagonals of a trapezium is parallel to and half of the difference of the parallel sides.
15. D and E are respectively the middle points of the sides AB and AC of the triangle $\triangle ABC$.
- 1) Express $(\overrightarrow{AD} + \overrightarrow{DE})$ in terms of \overrightarrow{AC}
 - 2) Prove with the help of vectors that, $BC \parallel DE$ and $DE = \frac{1}{2}BC$
 - 3) If M and N are the middle points of the diagonals of the trapezium $BCED$, then prove with the help of vectors that $MN \parallel DE \parallel BC$ and $MN = \frac{1}{2}(BC - DE)$
16. D, E and F are the middle points of the sides BC, CA and AB of the $\triangle ABC$, respectively.
- 1) Express \overrightarrow{AB} in terms of the vectors \overrightarrow{BE} and \overrightarrow{CF} .
 - 2) Prove that $\overrightarrow{AD} + \overrightarrow{BE} + \overrightarrow{CF} = \underline{0}$
 - 3) Prove with the help of vectors that the straight line drawn through F parallel to BC must go through E .

Chapter 13

Solid Geometry

Solids of different shapes are always needed and used in our practical life. Among these, there are regular and irregular solids. The method of determining volumes and areas of surfaces of regular solids and compound solids constructed of two regular solids will be discussed in this chapter.

At the end of this chapter, the students will be able to –

- ▶ draw the symbolic diagram of a solid;
- ▶ determine volumes and areas of surfaces of prism, solids of pyramid shape, spheres and right circular cones;
- ▶ solve problems using the knowledge of solid geometry;
- ▶ measure volumes and areas of surfaces of compound solids;
- ▶ apply the knowledge of solid geometry in practical areas.

Basic Concepts

Basic concepts of points, lines and planes have been discussed in secondary general geometry. In solid geometry point, lines and planes are considered as basic concepts.

1. Each of length, breadth and height of a body is called a dimension of the body.
2. A point has no length, breadth or thickness. It is an assumption. For practical purpose, we use a dot (\cdot) to indicate a point. It can be called a replica of position. Hence a point has no dimension. So it is zero-dimensional.
3. A line has length only, but no breadth and height. Hence a line is one dimensional. For example, in the figure below, AB is a line.
4. A surface has length and breadth, but no height. Hence a surface is two-dimensional. For example, in the figure below, $ABGF$ is a surface.

5. A body having length, breadth and thickness is called a solid. Hence a solid is three dimensional. For example, in the figure below, $ABCDEFGH$ is a body.

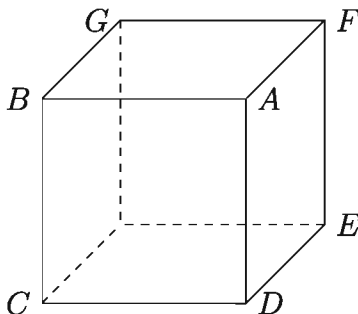

Some Elementary Definition

Drawing a three-dimensional figure on a two-dimensional page or board is a bit complex. So, drawing pictures with definitions in the classroom will help the students grasp the concepts easily.

1. **Plane surface:** If the straight line joining any two points on a surface lies totally on that surface, then the surface is called a plane surface or simply a plane. The upper surface of the still water of a pond is a plane. The smooth floor of a room polished with cement or mosaic is considered to be a plane. But geometrically it is not a plane, for there are high and low points on the floor. In the above picture, $ABCD$, $ADEF$, $ABGF$ all are planes.

Observation: Unless otherwise mentioned, lines and planes in solid geometry are regarded as infinitely extended. Hence it may be inferred from the definition of a plane that if one part of a straight line lies in a plane then the other part cannot be outside it.

2. **Curved surface:** If the straight line joining any two points on a surface does not lie wholly in the surface, then the surface is called a curved surface. The surface of a sphere is a curved surface.
3. **Solid geometry:** The branch of mathematics which concerns with the properties of solids and surfaces, lines and points is called solid geometry. Sometimes it is called Geometry of Space or Geometry of Three Dimensions.
4. **Coplanar straight lines:** If two or more straight lines lie in the same plane or a plane can be made to pass through them, then these straight lines are said to be coplanar. In the figure above AB and CD are coplanar straight

lines but EF is not coplanar with them.

5. **Skew or non coplanar lines:** Straight lines which do not lie in one plane or through which a plane cannot be made to pass are called skew or non-coplanar straight lines. In the figure above, AB and EF are skew lines. If two pencils are tied cross-wise like a plus sign or a multiplication sign, two non-coplanar lines are formed.
6. **Parallel Straight lines:** Two coplanar straight lines are said to be parallel, when they do not intersect each other, i.e., they have no common point. In the figure above, AB and CD are parallel straight lines.
7. **Parallel planes or surfaces:** Two planes are said to be parallel when they do not intersect, that is, they do not have any common point. In the figure above $ABCD$ and $EFGH$ are parallel planes.
8. **Line parallel to a plane:** If a plane and a straight line are such that they do not intersect though they are extended indefinitely, then the straight line is said to be parallel to the plane. In the figure above, CD is parallel to plane $ABGF$.
9. **Normal or perpendicular to a plane:** A straight line is said to be normal or perpendicular to a plane when it is perpendicular to every straight line in the plane meets it. In the figure below on left, OP is normal to the plane, as it is normal to all of AB , CD , EF residing on the plane.

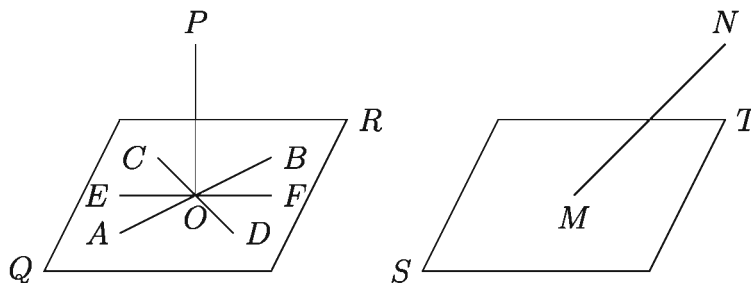

10. **Oblique Line:** A straight line is said to be an oblique line to a plane if it is neither parallel nor perpendicular to the plane. In the figure above on right, MN , ST are oblique lines.
11. **Vertical Line of Plane:** A straight line or a plane is said to be vertical when it is parallel to plumb line hanging freely at rest. In the figure below on left, $ABCD$ is a vertical plane and PR vertical line.

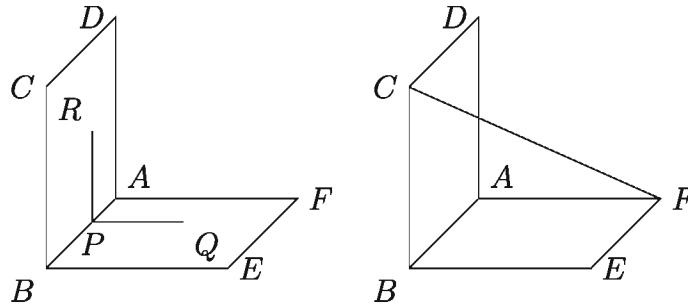

12. **Horizontal line or plane:** A plane is said to be horizontal when it is perpendicular to a vertical line. Again a straight line is said to be horizontal when it is perpendicular to a vertical line or when it lies in a horizontal plane. In the figure above on left, $ABEF$ is a horizontal plane and PQ is a horizontal line.
13. **Planar and skew quadrilateral:** A quadrilateral is said to be plane when its sides lie in the same plane. Again a quadrilateral whose sides do not lie in the same plane is called skew quadrilateral. Two adjacent sides of a skew quadrilateral lie in one plane and the other two adjacent sides lie in another plane. Hence the opposite sides of a skew quadrilateral are also skew. In the above figure on right, $ABEF$ is a planar quadrilateral and $BCFE$ is a skew quadrilateral.
14. **Angle between two skew straight lines:** The angle between two skew straight lines is the angle between one of them and the line drawn through any point in that line parallel to other. Again if two straight lines parallel to skew straight lines are drawn at a point, then the angle formed at that point is equal to the angle between the skew straight lines.

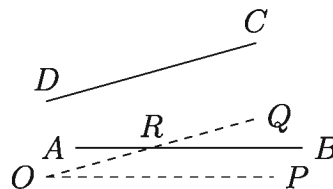

Let AB and CD be the skew lines. Take any point O and through O , draw OP, OQ , parallel to AB, CD respectively. Then the angle POQ indicates the angle between the skew lines AB and CD . In other words, $\angle BRQ$ also denotes the angle between AB and CD where R is on AB and QR is parallel to CD .

15. **Dihedral angle:** If two planes intersect in a straight line, then the angle between the two straight lines drawn from any point on the line of intersection and at right angles to the intersection line is called a dihedral angle.

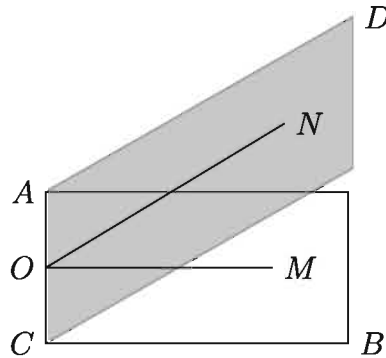

The two planes AB and CD intersect along the straight line AC . From O , any point on AC , two straight lines OM in the plane AB and ON in the plane CD are drawn such that each is perpendicular to AC at O . Then $\angle MON$ is the dihedral angle between the plane AB and CD . Two intersecting planes are said to be perpendicular to each other when the dihedral angle between them is a right angle.

16. **Projection:** The projection of a point on a given line or a plane is the foot of the perpendicular drawn from the point to the line or plane. The projection of a line straight or curved on a plane is the locus of the feet of the perpendiculars drawn from all points in the given line to the given plane. It is also called orthogonal projection. In the figure, projections of a curved line AB on plane XY and a line CD are shown as curved line ab and straight line cd .

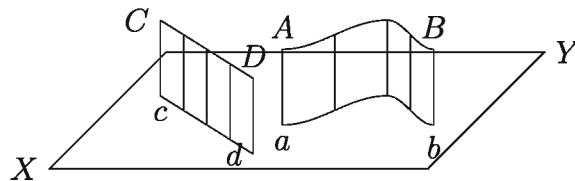

Relation between two straight lines

- 1) Two straight lines may be coplanar in which case they must either be parallel or meet in a point.

- 2) Two straight lines may be skew in which case they will neither be parallel nor will they meet in a point.

Axioms

- 1) A straight line joining any two points in a plane lies wholly in that plane, though produced indefinitely. Hence if a straight line and a plane have two common points, they will have innumerable common points along the straight line.
- 2) An infinite number of planes can be drawn through one or two given straight lines.

Relation between a straight line and a plane

- 1) If a straight line is parallel to a plane, then there will be no common point between them.
- 2) If a straight line cuts a plane, then they will have one and only one point common to them.
- 3) If a straight line and a plane have two common points then the line will completely coincide with the plane

Relation between two planes

- 1) If two planes are parallel then they will have no common point.
- 2) If two planes intersect each other, then they will intersect one another in a straight line and they will have innumerable common points.

Solid

We know that a book, a brick, a box or a spherical ball is a solid and occupies some space. Again, a piece of stone or wood, a part of a brick, a fragment of coal, a lump of dried sticky soil etc are also examples of solids. But these are irregular solids.

The body enclosed by plane or curved surfaces and occupying some space is called a solid. At least three straight lines are required to enclose a portion of a plane, so also four planes are required to enclose some space. These planes are the faces or the **surfaces** of the solid and the line in which two such planes intersect is an **edge** of the solid. A book or a brick has six faces and twelve edges. A cricket ball is enclosed by a curved surface.

Activity:

- 1) Write the name of a regular and an irregular solid individually.
- 2) Mention some uses of the solids cited by you.

Volume and area of surface of uniform solids

1. Rectangular Parallelepiped

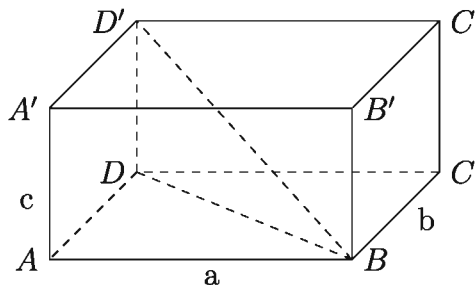

The solid enclosed by three pairs of parallel planes is called a parallelepiped. Each of the six planes is a parallelogram and the opposite faces are congruent. A parallelepiped has twelve edges divided into three groups.

The parallelepiped of which the faces are rectangles is called a rectangular parallelepiped. The rectangular parallelepiped of which the faces are squares is called a cube. The faces of the rectangular parallelepiped and the faces of the cube in the above diagram are $ABCD$, $A'B'C'D'$, $BCC'B'$, $ADD'A'$, $ABB'A'$, $DCC'D'$ and the edges are AB , $A'B'$, CD , $C'D'$, BC , $B'C'$, AD , $A'D'$, AA' , BB' , CC' , DD' . The only diagonal shown is BD' , the rest have to be drawn.

Let the length, breadth and height of the rectangular parallelepiped be respectively $AB = a$ units, $AD = b$ units and $AA' = c$ units.

1) Area of the whole surface

= Sum of the areas of the six faces

= 2 (the area of the face $ABCD$ + the area of the face $ABB'A$ + the area of the face $ADD'A$) = $2(ab+ac+bc)$ square units = $2(ab+bc+ca)$ square units

2) Volume = $AB \times AD \times AA'$ cubic units = abc cubic units

3) Diagonal

$$BD' = \sqrt{BD^2 + DD'^2} = \sqrt{AB^2 + AD^2 + DD'^2} = \sqrt{a^2 + b^2 + c^2} \text{ unit}$$

2. Cube

For a cube, $a = b = c$, Therefore,

1) Area of the whole surface = $2(a^2 + a^2 + a^2) = 6a^2$ square units

2) $= a \cdot a \cdot a = a^3$ cubic units

3) $= \sqrt{a^2 + a^2 + a^2} = \sqrt{3}a$ units

Example 1. A rectangular parallelepiped has its length, breadth and height in the ratio 4 : 3 : 2 and the area of its whole surface is 468 square metres; find the diagonal and the volume of it.

Solution: Let the length, breadth and height be respectively $4x$, $3x$ and $2x$ metres.

$$\text{Then, } 2(4x \cdot 3x + 3x \cdot 2x + 2x \cdot 4x) = 468$$

$$\text{or, } 52x^2 = 468 \text{ or, } x^2 = 9 \therefore x = 3$$

\therefore The length of the solid is 12 metres, the breadth is 9 metres and the height is 6 metres.

$$\text{Hence, the length of the diagonal} = \sqrt{12^2 + 9^2 + 6^2} \text{ metres} = \sqrt{144 + 81 + 36} = \sqrt{261} \text{ metres} \approx 16.16 \text{ metres (approx.)}$$

$$\text{And volume} = 12 \times 9 \times 6 = 648 \text{ cubic metres}$$

Activity: Measure the length, breadth and height of a hardboard box (cartoon or box containing a bottle of medicine) and find its volume, area of six surfaces and the length of a diagonal.

3. Prism

A prism is a polyhedron, bounded by two parallel polygonal faces and the other faces always being parallelograms. The parallel sides are known as **bases** and the sides are known as **lateral faces**. If all the lateral surfaces are rectangular it is called a **right prism**; otherwise they are called **oblique prism**. Practically right prisms are frequently used. The prism is named by the shape of its base. For example, triangular prism, quadrilateral prism, pentagonal prism etc.

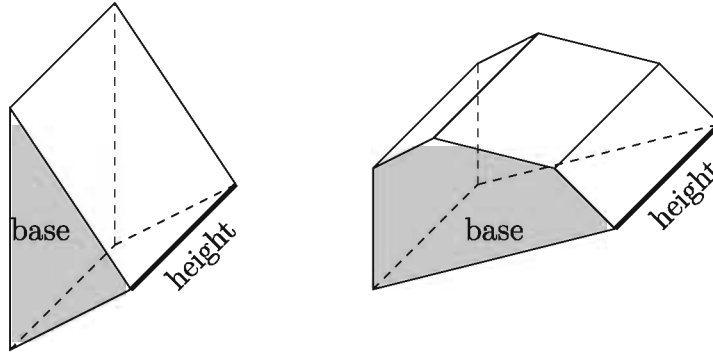

If the base is a regular polygon, the prism is called a **regular prism**. If the base is not a regular polygon, the prism is known as an **irregular prism**. So by definition all rectangular solids and cubes are prisms. Right triangular prism made of glass is used for the scattering of light.

1) The area of total surfaces of a prism

$$= 2 (\text{area of the base}) + \text{area of the lateral surfaces}$$

$$= 2 (\text{area of the base}) + \text{perimeter of the base} \times \text{height}$$

2) volume = area of the base \times height

Example 2. The lengths of the sides of the base of a triangular prism are 3, 4 and 5 cm respectively and the height is 8 cm. Find the volume and area of its total surfaces.

Solution: The lengths of the sides of the base of the prism are 3 cm, 4 cm and 5 cm respectively.

Since $3^2 + 4^2 = 5^2$, its base is a right angled triangle whose area = $\frac{1}{2} \times 4 \times 3 = 6$ sq. cm. So, the area of all the surfaces = $2 \times 6 + (3 + 4 + 5) \times 8 = 12 + 96 = 108$ sq. cm. and volume of the prism = $6 \times 8 = 48$ cubic cm.

So, the area of all the surfaces is 60 sq. cm. and the volume is 48 cubic cm.

4. Pyramid

A solid figure with a polygonal base and triangular faces that meet at a common point is called a pyramid.

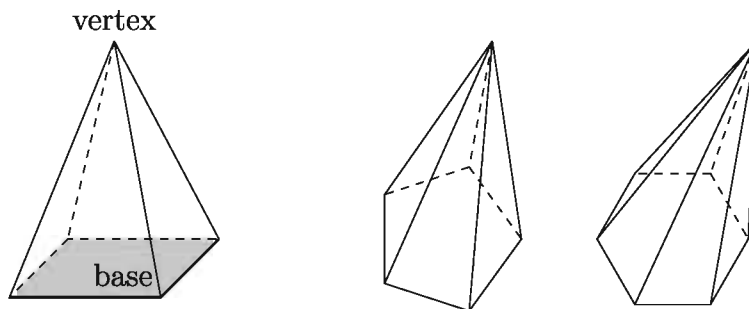

The base of a pyramid is a any polygon and its lateral surfaces are of any triangular shape. But if the base is a regular polygon and the lateral faces are congruent triangles, the pyramid is called **regular pyramid**. The regular pyramids are eye-catching. The line joining the vertex and any corner of the base is called the **edge** of the pyramid. The length of the perpendicular from the vertex to the base is called the **height** of the pyramid. Usually, a solid with a square base and four congruent triangles meeting at a point is considered as a pyramid. These pyramids are in wide use.

A solid enclosed by four equilateral triangles is known as **regular tetrahedron** which is also a pyramid. This pyramid has $3 + 3 = 6$ edges and 4 vertices. The perpendicular from the vertex falls on the centroid of the base.

- 1) The area of all surfaces of pyramid = Area of the base + area of the lateral surfaces

But if the lateral surfaces are congruent triangles,

The area of all surfafes of the pyramid = Area of the base + $\frac{1}{2}$ (perimeter of the base \times slant height)

If the height of the pyramid is h , radius of the inscribed circle of the base is r and l is its slant height, then $l = \sqrt{h^2 + r^2}$

- 2) volume = $\frac{1}{3} \times$ area of the base \times height

Example 3. The height of a pyramid with a square base of side 10 cm. is 12 cm. Find its area of all surfaces and the volume.

Solution: The perpendicular distance of any side of the base from the centre $r = \frac{10}{2}$ cm. = 5 cm., The height of the pyramid is 12 cm.

Therefore, the slant height of any lateral surface = $\sqrt{h^2 + r^2} = \sqrt{12^2 + 5^2}$
 $= \sqrt{144 + 25} = \sqrt{169} = 13$ cm.

\therefore The area of all the faces = $[10 \times 10 + \frac{1}{2}(4 \times 10) \times 13]$ sq. cm.
 $= 100 + 260 = 360$ sq. cm.

And its volume = $\frac{1}{3} \times (10 \times 10) \times 12$ cubic cm. = $10 \times 10 \times 4 = 400$ cubic cm.

Therefore, the area of all surfaces of the pyramid is 360 sq. cm. and the volume is 400 cubic cm.

Activity:

- 1) Draw a regular and an irregular (1) prism and (2) pyramid.
- 2) If possible, find the total surface area and the volume of the solids drawn by you.

5. Right circular cone

The solid formed by a complete revolution of a right-angled triangle about one of its sides adjacent to the right angle as axis is called a right circular cone.

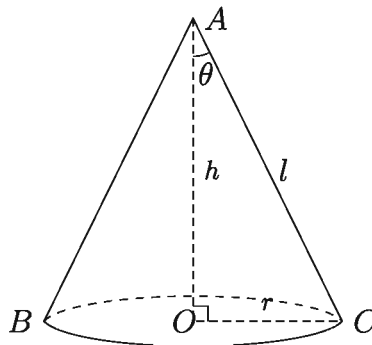

In the figure, the right circular cone ABC is formed by revolving the right-angled triangle OAC about OA . In this case, if θ is the vertical angle $\angle OAC$ of the triangle then it is called the Semi-vertical Angle of the cone.

If the circular cone has the height $OA = h$, radius of the base $OC = r$ and slant height $AC = l$, then

- 1) Area of the curved surface = $\frac{1}{2} \times$ circumference of the base \times slant height

$$= \frac{1}{2} \times 2\pi r \times l = \pi r l \text{ square units}$$

2) Area of the whole surface = Area of the curved surface + area of base
 $= \pi r l + \pi r^2 = \pi r(r + l)$ square units

3) Volume = $\frac{1}{3} \times$ area of base \times height
 $= \frac{1}{3} \pi r^2 h$ cubic units [You will learn the method of deduction of this formula in higher classes]

Example 4. If a right circular cylinder has a height of 12 cm. and a base of diameter 10 cm., then find its slant height, the area of the curved surface and the whole surface and its volume .

Solution: Radius of the base $r = \frac{10}{2}$ cm = 5 cm

Slant height $l = \sqrt{h^2 + r^2} = \sqrt{12^2 + 5^2} = 13$ cm

Area of the curved surface = $\pi r l = \pi \times 5 \times 13 = 204.2035$ sq cm (approx)

Area of the whole surface = $\pi r(l + r) = \pi \times 5 \times (13 + 5) = 282.7433$ sq cm

(approx) Volume = $\frac{1}{3} \pi r^2 h = \frac{1}{3} \pi \times 5^2 \times 12 = 314.1593$ cubic cm (approx)

Activity: Collect a conical cap used in birthday or any ceremonial parties and find the volume and the area of its curved surface.

6. Sphere

The solid formed by a complete revolution of a semi-circle about its diameter as axis is called a sphere. The centre of the semi-circle is the centre of the sphere. The surface formed by the revolution of the semi-circle about its diameter is the surface of the sphere.

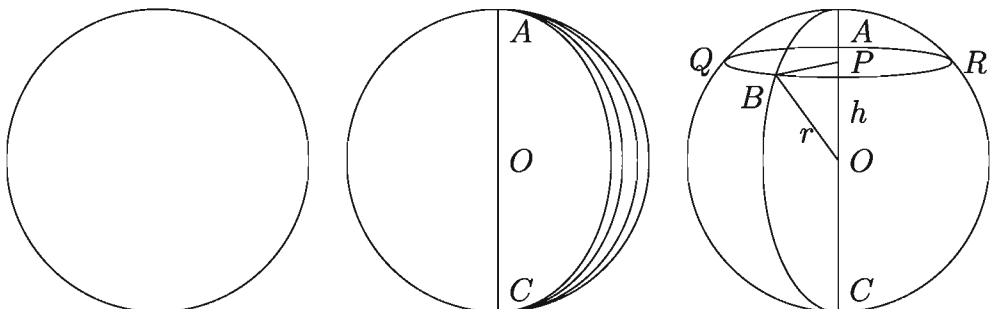

The centre of the sphere $CQAR$ is the point O , radius $OA = OB = OC$ and a plane perpendicular to OA and passing through a point at a distance h from the centre cuts the sphere and form the circle QBR . The centre of this circle is P and the radius is PB . Then PB and OP are perpendicular to each other.

$$\therefore OB^2 = OP^2 + PB^2$$

$$\therefore PB^2 = OB^2 - OP^2 = r^2 - h^2$$

If the radius of the sphere is r then

- 1) Area of the surface of the sphere = $4\pi r^2$ sq units
- 2) Volume = $\frac{4}{3}\pi r^3$ cubic units
- 3) Radius of the circle formed by the section of a plane at a distance h from the centre = $\sqrt{r^2 - h^2}$ unit

Activity: Find the radius of a toy ball or a football. Hence find its volume.

Example 5. An iron sphere of diameter 4 cm. is flattened into a circular iron sheet of thickness $\frac{2}{3}$ cm. What is the radius of the sheet?

Solution: Radius of the iron sphere = $\frac{4}{2} = 2$ cm

$$\therefore \text{its volume} = \frac{4}{3}\pi \times 2^3 = \frac{32}{3}\pi \text{ cubic cm}$$

Let, the radius of the sheet = r cm; The thickness of the sheet = $\frac{2}{3}$ cm

$$\therefore \text{Volume of the sheet} = \pi r^2 \times \frac{2}{3} \text{ cubic centimetres} = \frac{2}{3}\pi r^2$$

By the given condition, $\frac{2}{3}\pi r^2 = \frac{32}{3}\pi$ or, $r^2 = 16$ or, $r = 4$

\therefore Radius of the sheet = 4 cm

Example 6. A right circular cone, a semi-sphere and a cylinder of equal heights stand on equal bases. Show that their volumes are in the ratio 1 : 2 : 3.

Solution: Let the common height and the radius of the equal bases be h and r units respectively. Since the height of a semi-sphere is equal to its

radius.

So, volume of the cone = $\frac{1}{3}\pi r^2 h = \frac{1}{3}\pi r^3$ cubic units

Volume of the semi-sphere = $\frac{1}{2}\left(\frac{4}{3}\pi r^3\right) = \frac{2}{3}\pi r^3$ cubic units

Volume of the cylinder = $\pi r^2 h = \pi r^3$ cubic units

\therefore Required ratio = $\frac{1}{3}\pi r^3 : \frac{2}{3}\pi r^3 : \pi r^3 = \frac{1}{3} : \frac{2}{3} : 1 = 1 : 2 : 3$

Example 7. The length, breadth and height of a rectangular block of iron are respectively 10, 8 and $5\frac{1}{2}$ cm. How many spherical shots of radius 12 cm. can be made by melting the block?

Solution: Volume of the iron block = $10 \times 8 \times 5\frac{1}{2}$ cubic cm. = 440 cubic cm.

Let the required number of shots = n

\therefore Volume of n shots = $n \times \frac{4}{3}\pi\left(\frac{1}{2}\right)^3 = \frac{n\pi}{6}$ cubic cm

By the condition of the question, $\frac{n\pi}{6} = 440$ or, $n = \frac{440 \times 6}{\pi} = 840.34$

\therefore Required number of shots is 840

Example 8. If the volume of a right circular cone is V , the area of its curved surface is S , radius of the base is r , height is h and semi-vertical angle is α . Then show that,

$$1) S = \frac{\pi h^2 \tan \alpha}{\cos \alpha} = \frac{\pi r^2}{\sin \alpha} \text{ square units.}$$

$$2) V = \frac{1}{3}\pi h^3 \tan^2 \alpha = \frac{\pi r^3}{3 \tan \alpha} \text{ cubic units.}$$

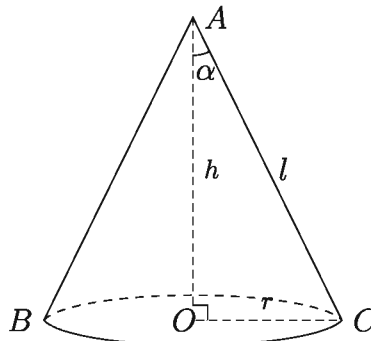

Solution: In the above diagram, height of the cone $OA = h$ slant height $AC = l$, radius of the base $OC = r$ the semi-vertical angle $\angle OAC = \alpha$
Here slant height $l = \sqrt{h^2 + r^2}$

From the diagram, it is seen that $\tan\alpha = \frac{r}{h}$

$$\therefore r = h \tan\alpha \text{ or, } h = \frac{r}{\tan\alpha} = r \cot\alpha$$

$$\begin{aligned} 1) \quad S &= \pi r l = \pi r \sqrt{h^2 + h^2 \tan^2 \alpha} = \pi r h \sqrt{1 + \tan^2 \alpha} = \pi r h \sqrt{\sec^2 \alpha} \\ &= \pi r h \sec \alpha = \pi (h \tan \alpha) h \sec \alpha = \frac{\pi h^2 \tan \alpha}{\cos \alpha} \text{ square units} \end{aligned}$$

$$\text{again, } S = \pi r h \sec \alpha = \frac{\pi r}{\cos \alpha} r \cot \alpha = \frac{\pi r^2 \cos \alpha}{\cos \alpha \sin \alpha} = \frac{\pi r^2}{\sin \alpha} \text{ square units}$$

$$\begin{aligned} 2) \quad V &= \frac{1}{3} \pi r^2 h = \frac{1}{3} \pi (h \tan \alpha)^2 h = \frac{1}{3} \pi h^3 \tan^2 \alpha = \frac{1}{3} \pi \left(\frac{r}{\tan \alpha} \right)^3 \tan^2 \alpha \\ &= \frac{\pi r^3}{3 \tan \alpha} \text{ cubic units} \end{aligned}$$

7. Compound solid

A solid body consisting of two solids is a compound solid. Examples of a few compound solids are:

- 1) A prism placed on a rectangular solid is a compound solid when both of them have identical surface.
- 2) If the base of a triangular prism and that of a regular tetrahedron are identical, they can be used to make a compound solid.
- 3) If the radius of a hemisphere and that of the base of a cone are equal, they can form together a compound solid.
- 4) A capsule is a compound solid having two identical hemispheres at two ends of a circular cylinder with base radius equal to the radius of each hemisphere.

In this way, two or more solids can be combined together to make a compound solid. Many beautiful architectural constructions are compound solids. The items used for exercises are made of such compound solids.

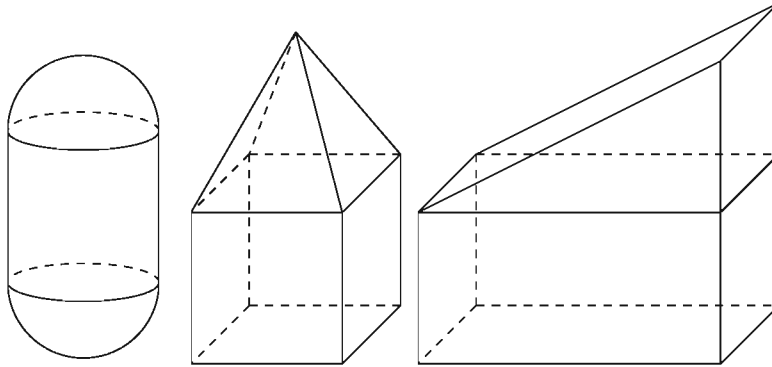

Activity: Draw and describe a compound solid on your own. Write down formula for its surface area and volume, if possible.

Example 9. The length and radius of a capsule is 15 cm. and 3 cm. respectively. Find the volume and total area of the surfaces of the capsule.

Solution: The length of the capsule is 15 cm. Since the two ends of the capsule are hemispherical, the length of its cylindrical part $l = 15 - (3 + 3) = 9$ cm.

Therefore, the total area of the surfaces of the capsule = area of the surfaces of two hemispheres + area of the surface of the cylinder

$$= 2 \times \frac{1}{2} \times 4\pi r^2 + 2\pi r l = 4\pi(3)^2 + 2\pi \times 3 \times 9 = 90\pi = 282.74 \text{ sq cm (approx)}$$

and the volume of the capsule

$$= 2 \times \frac{1}{2} \times \frac{4}{3}\pi r^3 + \pi r^2 l = \frac{4}{3}\pi(3)^3 + \pi(3)^2 \times 9 = 117\pi = 367.57 \text{ cubic cm. (approx)}$$

Example 10. The outer diameter of a hollow iron sphere is 15 cm. and thickness is 2 cm.

- 1) Determine the volume of the hollow portion.
- 2) If a solid sphere is made out of the iron used in the sphere mentioned, then what would be the area of the total surface of the solid sphere?
- 3) The solid sphere fits fine in a cubic box. What is the volume of the hollow space inside the box?

Solution:

- 1) Given, Outer diameter of the sphere is 15 cm.

\therefore Outer radius of the sphere = $\frac{15}{2}$ cm. = 7.5 cm. and thickness of the sphere is 2 cm.

\therefore radius of the hollow portion of the sphere = $(7.5 - 2)$ cm. = 5.5 cm.

\therefore volume of the hollow portion of the sphere = $\frac{4}{3}\pi r^3 = \frac{4}{3}\pi \times (5.5)^3 = 696.9116$ cubic cm (approx)

2) Here, radius of the sphere is 7.5 cm.

\therefore Volume of the sphere = $\frac{4}{3}\pi \times (7.5)^3 = 1767.15$ cubic cm. (approx)

\therefore Volume of the iron used in the sphere = $(1767.15 - 696.9116) = 1070.2384$ cubic cm (approx)

Let, radius of the solid sphere is r cm.

\therefore Volume of the solid sphere = $\frac{4}{3}\pi \times r^3$ cubic cm.

As the iron of the hollow sphere is used to make the solid sphere, volume of the iron is equal to the solid sphere's volume.

$\therefore \frac{4}{3}\pi \times r^3 = 1070.2384$ or, $r^3 = 255.5$ or, $r = 6.3454$ cm.

\therefore Surface area of the solid sphere = $4\pi \times (6.3454)^2 = 505.9748$ sq cm (approx)

3) volume of the solid sphere 6.3454 cm.

\therefore diameter of the solid sphere = 2×6.3454 cm. = 12.6908 cm.

As the solid sphere fits the box, so the box's side length will be the diameter of the solid sphere. Therefore, the length is = 12.6908 cm.

\therefore Volume of the box = $(12.6908)^3 = 2043.9346$ cubic cm (approx)

Volume of the solid sphere = Volume of the iron in hollow sphere = 1070.2384 cubic cm (approx)

\therefore Hollow portion's volume of the box = $(2043.9346 - 1070.2384) = 973.6962$ cubic cm (approx)

Exercise 13

1. A rectangular parallelepiped's length is 5 cm, width 4 cm and height 3 cm. What's its diagonal?

- 1) $5\sqrt{2}$ cm 2) 25 cm 3) $25\sqrt{2}$ cm 4) 50 cm

2. Lengths of other two sides except the hypotenuse of a right-angled triangle are 4 cm. and 3 cm. If the triangle is revolved about the larger side, the evolved solid will be a

- (i) right circular cone
 (ii) right circular cylinder
 (iii) the area of the base of the evolved solid is 9π square centimetres.

Which one of the above sentences is correct?

- 1) *i* 2) *ii* 3) *i iii* 4) *ii iii*

Answer to the questions 3 and 4 according to the informations given below.

A spherical ball of diameter 2 cm. exactly fits in a cylindrical box

3. What is the volume of the cylinder?

- 1) 2π cc 2) 4π cc 3) 6π cc 4) 8π cc

4. What is the volume of the unoccupied portion of the cylinder?

- 1) $\frac{\pi}{3}$ cc 2) $\frac{2\pi}{3}$ cc 3) $\frac{4\pi}{3}$ cc 4) $\frac{3\pi}{3}$ cc

Answer to the questions 5 and 6 according to the informations given below.

A metallic solid sphere of diameter 6 cm. is melted and a right circular cylinder the radius of whose base is 3 cm. is made.

5. What is the height of the cylinder made?

- 1) 4 cm 2) 6 cm 3) 8 cm 4) 12 cm

6. What is the area of the curved surface of the cylinder in square centimetres?

- 1) 24π 2) 42π 3) 72π 4) 96π

(Calculator can be used. If required, you can assume $\pi = 3.1416$)

7. The length, breadth and height of a rectangular parallelopiped are respectively 16 metres 12 metres and 4.5 metres. Find the area of its surfaces, volume and length of a diagonal.

8. A rectangular tank of length 2.5 metres, breadth 1.0 metre stands on the ground. If its height is 0.4 metre, find the volume and its area of the interior surface.

9. Find the area of the whole surface of the cube whose edge is equal to the diagonal of the rectangular solid whose dimension are 5, 4 and 3 cm.

10. A hostel building is to be constructed for 70 students in which each student gets 4.25 square metres of floor and 13.6 cubic metres of space. If the hostel room is 34 metres long, what will be its breadth and height?
11. If the height of a right circular cone is 8 cm and the radius of its base is 6 cm, find the area of the whole surface and the volume.
12. The height of a right circular cone is 24 cm. and its volume is 1232 cubic cm. What is its slant height?
13. The length of two sides at the right angle of a right-angled triangle is 5 cm. and 3.5 cm. Find the volume of the solid formed by revolving it about its greater side.
14. Find the surface and volume of a sphere of radius 6 cm.
15. Three spherical balls of glass of radii 6, 8 and r cm. are melted and formed into a single solid sphere with radius 9 cm. Find the value of r .
16. The outer diameter of a hollow sphere is 13 cm. and the thickness of the iron is 2 cm. A solid sphere is formed with the iron used in the hollow sphere. What will be its diameter?
17. A solid sphere of radius 4 cm. is melted and formed into a uniform hollow sphere of outer radius 5 cm. Find the thickness of the second sphere.
18. The radius of a solid sphere of iron is 6 cm. With the iron contained in it, how many solid cylinders of length 8 cm. and diameter of the base 6 cm. can be formed?
19. A spherical ball of radius $\frac{22}{\pi}$ cm. exactly fits into a cubical box. Find the volume of the unoccupied portion of the box.
20. A sphere of radius 13 cm. is cut off by a plane perpendicular to its diameter through a point at a distance 12 cm. from the centre. Find the area of the plane formed.
21. The outer length, breadth and height of a wooden box with top are respectively 1.6, 1.2 and 0.8 metres and its wood is 3 cm. thick. What is the area of the inner surface of the box? What will be the cost of painting the inner surface of the box at the rate of Tk. 14.44 per square metre?
22. How many bricks each of length 25 cm., breadth 12.5 cm. and 8 cm. will be required to construct a wall of height 2 metres and thickness 25 cm. around a rectangular garden with length 120 metres and width 90 metres?

23. The length and breadth of a rectangular solid are in the ratio 4 : 3 and its volume is 2304 cubic centimetres. The total cost of making a solid with lead coating at the bottom at Tk. 10 per square centimetre is Tk. 1920. Find the dimensions of the solid.
24. A conical tent has a height of 7.50 metres. How much canvas will be required if it is desired to enclose a land of 2000 square metres?
25. Lengths of two sides of a prism with a pentagonal base are 6 cm. and 8 cm. and the length of each of the other three sides is 10 cm., height is 12.5 cm. Find the total area of the surfaces and the volume of the prism.
26. The height of a regular hexagonal prism having side of 4 cm. is 5 cm. Find the total area of surfaces and the volume.
27. A pyramid is situated on a regular hexagon of side 6 cm. and its height is 10 cm. Determine the total area of surfaces and the volume.
28. If the length of an edge of a regular tetrahedron is 8 cm., find the total area of surfaces and the volume.
29. The lower part of a construction is a parallelepiped of length 3 metres and the upper part is a regular pyramid. If the base of the pyramid is of side 2 metres and the height is 3 metres, find the total area of surfaces and the volume of the construction.
30. A godown of two-part roof is constructed on a land of length 25 metres and width 18 metres. Its height is 5 metres. Each part of the roof is of 14 metres wide. Find the volume of the godown.
31. 1) Find the total area of surfaces of the solid shown in the diagram.

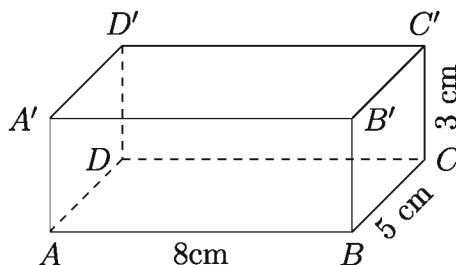

- 2) Find the approximate number (to the nearest integer) of solid spheres of diameter 1.8 cm which can be made after melting a cube whose sides are equal to the diagonal of the solid.

32. The diameter of the base of a tent like a right circular cone is 50 metres and its height is 8 metres.
- 1) Find the slant height of the tent.
 - 2) How much land in square metres will be required to construct the tent?
Find the volume of the vacuum space inside the tent.
 - 3) What will be the cost of the canvas of the tent if its price is Tk. 125 per square metre?

Chapter 14

Probability

In our everyday life we frequently use the word ‘probability.’ For example, the probability of Jaadob passing the SSC examination this year is really poor, the probability of Bangladesh winning the Asia cup is high, the probability of the temperature rising tomorrow is high, the probability of raining today is very thin etc.

Therefore, we talk about probability only when there is a doubt about an event occurring. And the possibility of the event occurring also depends on the magnitude of non-occurrence. But this procedure can not give any numerical value. In this chapter, we will know about different formulas and procedures for assigning a numerical value to the probability of the occurrence of an event, and we will also be able to describe certain events, impossible events and possible events after studying this chapter.

After studying this chapter, students will be able to —

- ▶ explain the concept of probability;
- ▶ describe certain events, impossible events and possible events by giving daily-life examples;
- ▶ describe the consequences of repetition of an event;
- ▶ find the probability of an event happening repeatedly;
- ▶ solve simple and real-life problems regarding probability.

Basic Concepts Related to Probability

Random Experiment: A random experiment is where you know all possible outcomes of the experiment, but you can not say the exact outcome of a certain attempt in this experiment. For example, we know all the outcomes of throwing

a dice, but we can not exactly tell which outcome will occur before throwing the dice. So the experiment of throwing a dice is a random experiment.

Event: An outcome or a combination of outcomes of an experiment is called an event. For example, getting 3 after throwing a dice is an event. Again, getting an even number in this regard is also an event.

Equally Likely Events: If the possibilities of the outcomes of a random experiment occurring are same, which means no outcome is more or less likely to happen than any other outcome, the possible outcomes are called equally likely events. For example, the occurrence of a head or a tail in the tossing of a coin are equally likely events, unless the coin is defective or biased in some way. Therefore, getting head and tail are equally likely events.

Mutually Exclusive Events: Two or more possible outcomes of a random experiment are called mutually exclusive event if the occurrence of one of those events precludes the possibility of the other events. For example, in the tossing of a coin, the occurrence of a head and a tail are mutually exclusive events since if head occurs then tail can not occur and vice versa. That means head and tail can not occur at the same time.

Favourable Outcomes: The outcome of interest of an event in an experiment is called favourable outcome. The number of favourable outcomes of getting an odd number on throwing a dice is 3.

Sample Space and Sample Point: The set of all possible outcomes of a random experiment is called the sample space. The tossing of a coin has two possible outcomes: Head and Tail. If the result of this experiment is expressed as S , we can write $S = \{H, T\}$. So in this case the sample space is $S = \{H, T\}$. Suppose two coins are tossed simultaneously. Then the sample space is $S = \{HH, HT, TH, TT\}$. Every element of a sample space is called a sample point. The experiment of throwing a dice once has the sample space $S = \{H, T\}$, and here each of H, T is a sample point.

Determination of Logic-Based Probabilities

Example 1. Suppose an unbiased dice is thrown. What is the probability of getting 5?

Solution: The possible outcomes of throwing a dice are : 1, 2, 3, 4, 5, 6. Since the dice is unbiased, these outcomes are all equally likely. So the possibility of a

particular outcome is one-sixth. So the probability of getting 5 is $\frac{1}{6}$. We write this as $P(5) = \frac{1}{6}$.

Example 2. What is the probability of getting an even number on throwing an unbiased dice?

Solution: The possible outcomes of throwing a dice are 1, 2, 3, 4, 5, 6. The even numbers among these outcomes are 2, 4, 6. So there are three outcomes where we can get an even number on the dice, which means there are 3 favourable outcomes. As all outcomes are equally likely, the probability of getting an even number on the dice is $\frac{3}{6}$.

$$\therefore P(\text{even number}) = \frac{3}{6}$$

So we can formalize the following definition of probability:

$$\text{Probability of an event} = \frac{\text{number of cases favourable to the event}}{\text{total number of possible outcomes}}$$

The number of cases favourable to an event can be minimum zero and maximum n (all possible outcomes). If there is no case favourable to an event then probability becomes zero. And when the amount of favourable outcome is n , then the probability is 1. Therefore, the probability of an event ranges from 0 to 1.

Two Special Events

Certain Events: An event which is sure to occur is called a certain event. The probability of any certain event is 1. For an instance, the probability that the sun will rise tomorrow from the east is 1, the probability that the sun will set in the west in this evening is likewise 1. The probability of not seeing the sun in the night is also 1. The probability of getting H or T is also 1. The probability of getting even or odd in an experiment of throwing dice is also 1. These are all certain events.

Impossible Events: An event which will not occur, that means which is not possible to occur in an experiment is called an impossible event. The probability of an impossible event is zero. For instance, the probability that tomorrow the sun will rise in the west or set in the east, is zero. The probability of seeing the sun in the night is zero too. Similarly, the probability of getting a 7 in throwing a dice is also zero. All these events mentioned here are impossible events.

Example 3. In a bag there are 4 red, 5 white and 6 black balls. A ball is chosen at random. What is the probability that the ball will be 1) red, 2) white and 3) black ?

Solution: Total number of balls in the bag is 15. If a ball is chosen randomly, any of the 15 balls may be drawn. Therefore total number of outcomes = 15.

- 1) Suppose the event of drawing a red ball is R . There are 4 red balls in the bag. So the number of favourable cases for this event = 4.

$$\therefore P(R) = \frac{\text{number of events favourable to draw a red ball}}{\text{total number of outcomes}} = \frac{4}{15}.$$

- 2) Suppose the event of drawing a white ball is W . There are 5 white balls in the bag. So the number of favourable cases for this event = 5. $\therefore P(W) = \frac{\text{number of events favourable to draw a white ball}}{\text{total number of outcomes}} = \frac{5}{15} = \frac{1}{3}$.

- 3) Suppose the event of drawing a black ball is B . There are 6 black balls in the bag. So number of favourable cases for the event = 6.

$$\therefore P(B) = \frac{\text{number of events favourable to draw a black ball}}{\text{total number of outcomes}} = \frac{6}{15} = \frac{2}{5}.$$

Activity:

- 1) An unbiased dice is thrown. Find the probability of getting:
 - (i) 4 (ii) an odd number (iii) 4 or a number greater than 4 (iv) a number less than 5.
- 2) A bag contains similar type of 6 black, 5 red, 8 white marbles. A marble is drawn at random from the bag. Find the probability that the marble is:
 - (i) red (ii) black (iii) white (iv) not black.

Data Based Probability

In the logical approach to determining probabilities, the outcomes are required to be equally likely. However, in reality the outcomes are not equally likely in all cases. Moreover, in many situations, it is not possible to apply the logical approach. For example, today's weather forecast says that the probability of raining today is 30%, the probability of Brazil winning the world football cup is 40%, the probability of Bangladesh winning the Asia cup is 60%. Then statement

are based on statistics or data of past records and this is the concept of data-based probability.

Suppose, a coin is tossed 1000 times which resulted in head 523 times. So the relative frequency of getting head is $\frac{523}{1000} = 0.523$. Suppose, a coin is tossed 2000 times which resulted in head 1030 times. So the relative frequency of H in 2000 times is $\frac{1030}{2000} = 0.515$. From this we can understand that, the more times an experiment (tossing of a coin) is done, the closer the relative frequency will be to the probability of getting a head in a single tossing of the coin. This is called data based probability.

Example 4. According to meteorological records, it rained on 21 days in the month of July last year. What is the probability that it will rain on fourth of July this year?

Solution: As out of the 31 days in the month of July, it rained on total 21 days last year, the probability of raining on a particular day of July this year is $\frac{21}{31}$. Therefore the probability of raining on fourth of July is $\frac{21}{31}$.

Example 5. In a survey among the readers of newspapers, it was found that 65 persons read the Prothom Alo, 40 persons read the Bhorer Kagoj, 45 read the Janakantho, 52 read the Jugantor. If one person is chosen at random from these readers, what is the probability that the person reads the Jugantor? What is the probability that the person does not read the Prothom Alo?

Solution: Here, the total number of readers is $(65 + 40 + 45 + 52) = 202$.

The number of persons reading the Jugantor is 52. So, the probability that the chosen person reads the Jugantor is $\frac{52}{202}$.

65 persons read the Prothom Alo. Number of persons who do not read the Prothom Alo is $(202 - 65) = 137$. So, the probability that the person does not read the Prothom Alo is $= \frac{137}{202}$

Activity: In a survey among the first year students in a university, it is found that 284 students have taken Economics, 106 have taken History, 253 have taken Sociology, 169 have taken English. If a student is chosen at random, what is the probability that the student has not taken Sociology?

Determination of Probability using Sample Space and Probability Tree

It has been already mentioned that the set of all possible outcomes of an experiment is called the sample space. Often the sample space of an experiment is quite large. In such cases, the counting of all sample points and the formation of the sample space may be cumbersome and can even lead to mistakes. In such cases we may build the sample space by using the probability tree, and use it to find the probability of various events.

Example 6. Suppose, two unbiased coins are tossed together. Form the sample space, find the probability of getting H on first coin and T on second coin.

Solution: The tossing of two coins may be treated as a two step process. In the first step, one of the coins is tossed which may result in either H or T . In the second step, the other coin is tossed which may, likewise, result in either H or T . All possible outcomes of this experiment may be exhibited in the form of a probability tree diagram as follows :

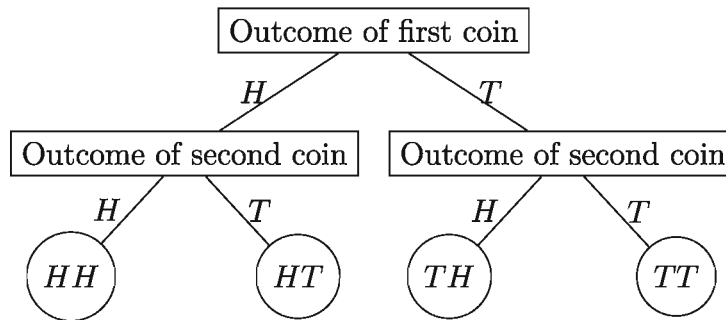

So the sample points are: HH, HT, TH, TT . So the sample space will be $\{HH, HT, TH, TT\}$. Here the number of sample points is 4 and the probability of observing a sample point is $\frac{1}{4}$. So the probability of getting H on the first coin and the probability of getting T on the second coin will be, $P(HT) = \frac{1}{4}$.

Example 7. Suppose, an unbiased coin is tossed thrice. Show the sample space using a probability tree and find the probabilities of the each of the following events. 1) getting just one tail, 2) getting head in all three tossings, 3) getting at least one tail.

Solution: The tossing of the coin three times may be treated as a three step process. In each toss the number of possible outcomes are two, which are H or T . The total result is shown below, using probability tree:

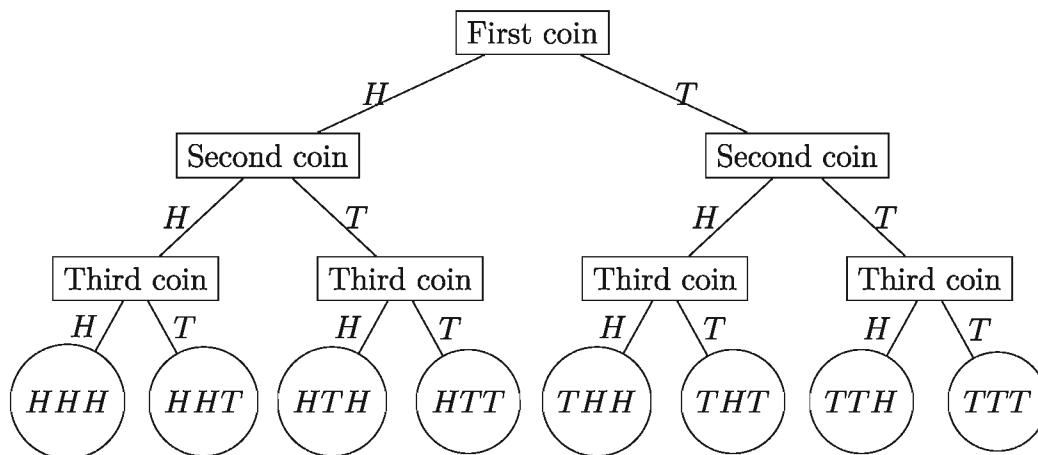

The sample space is: $\{HHH, HHT, HTH, HTT, THH, THT, TTH, TTT\}$.

Here the total number of sample points is 8 and the probability of any one of these outcomes is $\frac{1}{8}$.

- 1) The sample points (outcomes) containing just one tail are $\{THH, HHT, HTH\} = 3$.

$$\therefore P(1T) = \frac{3}{8} \text{ (as possibility of occurring every sample point is } \frac{1}{8} \text{)}$$

- 2) Getting head (H) in all three tossings is the outcome $\{HHH\} = 1$ outcome.

$$\therefore P(HHH) = \frac{1}{8}$$

- 3) The sample points containing at least one tail (T) are all except HHH which means $\{HHT, HTH, HTT, THH, THT, TTH, TTT\} = 7$.

$$\therefore P[\text{at least } 1T] = \frac{7}{8}$$

Example 8. An unbiased dice and an unbiased coin are thrown and tossed once. Form the probability tree and write down the sample space. Find the probability of getting 5 on the dice and H on the coin.

Solution: The throwing of a single dice and the tossing of a single coin may be treated as a two step process. In the first step, 6 possible outcomes are possible which are $\{1, 2, 3, 4, 5, 6\}$. In the second step, the tossing of the coin will result in 2 possible outcomes which are H or T. The corresponding probability tree is shown below:

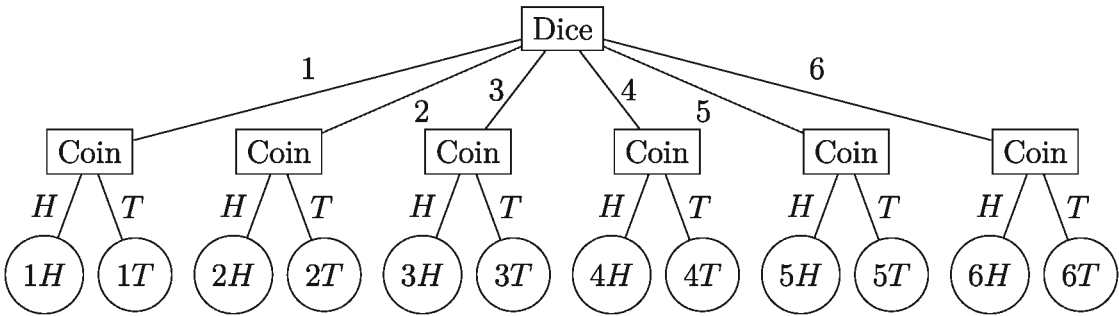

Therefore, the sample space will be: $\{1H, 1T, 2H, 2T, 3H, 3T, 4H, 4T, 5H, 5T, 6H, 6T\}$.

Here the total number of sample points is 12. \therefore The probability of getting 5 on the dice and H on the coin is $P(5H) = \frac{1}{12}$.

Example 9. The probability that a person will travel from Dhaka to Khulna by bus is $\frac{2}{5}$ and that he will travel from Khulna to Rajshahi by train is $\frac{5}{8}$. Use a probability tree to determine the probability that the person will travel to Khulna by bus and will subsequently travel to Rajshahi not by train.

Solution: The probability tree will be

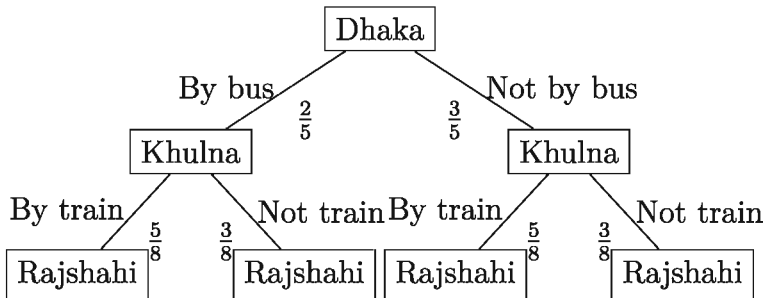

Therefore, the probability that the person will travel from Dhaka to Khulna by bus and then from Khulna to Rajshahi not by train is

$$P[\text{Khulna by bus, Rajshahi not by train}] = \frac{2}{5} \times \frac{3}{8} = \frac{6}{40} = \frac{3}{20}$$

Activity:

- 1) Write down all possible outcomes of three tossings of a coin using a probability tree and find the sample space. From these, find the probability of getting (i) the same outcome in all three tossings (ii) at

least $2T$ (*iii*) at most $2T$.

- 2) Construct a probability tree for throwing of one dice and two coins.

Exercise 14

1. Which is the probability of getting 3 in a throw of a dice?

- 1) $\frac{1}{6}$ 2) $\frac{1}{3}$ 3) $\frac{2}{3}$ 4) $\frac{1}{2}$

Answer questions 2 and 3 based on the information given below:

A ball is drawn at random from a bag containing 12 blue, 16 white and 20 black balls.

2. What is the probability that the ball is blue?

- 1) $\frac{1}{16}$ 2) $\frac{1}{12}$ 3) $\frac{1}{8}$ 4) $\frac{1}{4}$

3. What is the probability that the ball is not white?

- 1) $\frac{1}{3}$ 2) $\frac{2}{3}$ 3) $\frac{1}{16}$ 4) $\frac{1}{48}$

Answer questions 4 and 5 based on following information:

A coin is tossed thrice.

4. What is the probability of getting a head more number of times than getting a tail?

- 1) $\frac{1}{6}$ 2) $\frac{1}{3}$ 3) $\frac{1}{2}$ 4) $\frac{2}{3}$

5. What is the probability of getting T zero number of times?

- 1) 0 2) $\frac{1}{2}$ 3) 1 4) $\frac{1}{8}$

6. In the case of throwing two coins–

(i) Probability of getting at most one $H = 0.75$

(ii) Probability of getting at least one $H = 0.75$

(iii) HH is a sample point.

Which one of the following is correct?

- 1) i, ii 2) i, iii 3) ii, iii 4) i, ii, iii

7. Thirty tickets are numbered serially from 1 to 30. The tickets are mixed thoroughly and one ticket is drawn at random. Find the probability of the serial number of the ticket being 1) an even number 2) divisible by 4 3) less than 4 4) greater than 22.
8. In a certain lottery 570 tickets have been sold. Rahim has bought 15 tickets. The tickets are mixed together thoroughly and one ticket is drawn at random for the first prize. What is the probability of Rahim getting the first prize?
9. What is the probability of getting an even number or a number divisible by 3 in a single throw of a dice?
10. According to the report of a health centre, 155 babies were born who were underweight, 386 babies were born with normal weight and 98 babies were born who were overweight. One baby is selected at random from these babies. What is the probability that the baby was overweight?
11. The employees employed in a factory can be classified based on the types of work they perform, as mentioned below:

Classification	Number of Employees
Managerial	157
Inspection	52
Production	1473
Office Work	215

If a person is selected randomly, then what is the probability of the person being—

- 1) involved in management duty?
 - 2) involved in managerial or production duty?
 - 3) not involved in production duty?
12. Out of 2000 newly licensed drivers. the following number of drivers violate the traffic rules in a single year.

Number of Violation of Traffic Rules	Number of Drivers
0	1910
1	46
2	18
3	12
4	9
More than 4	5

- 1) Out of these 2000 drivers, if one driver is chosen at random what is the probability that the driver has violated traffic rules once? 2) What is the probability that the driver has violated traffic rules more than 4 times?
13. Form a probability tree for tossing a coin and throwing a dice successively.
14. Fill up the following table with the help of probability trees:

Tossing of a coin	All possible outcomes	Probability
One tossing of a coin		$P(T) =$
Two tossings of a coin		$P(1H) =$ $P(HT) =$
Three tossings of a coin		$P(HHT) =$ $P(2H) =$

15. The probability that a certain person will travel from Dhaka to Rajshahi by train is $\frac{5}{9}$ and that subsequently the person will travel from Rajshahi to Dinajpur by bus is $\frac{2}{7}$. Using a probability tree –
- 1) Find the probability that the person will travel from Dhaka to Rajshahi not by train and then travel to Dinajpur by bus.
 - 2) Find the probability that the person will travel from Dhaka to Rajshahi by train and then travel to Dinajpur not by bus.
16. The probability that a person will travel from Dhaka to Chittagong by train is $\frac{2}{9}$, the probability that the person will travel by bus is $\frac{3}{7}$ and the probability that he will take a flight is $\frac{1}{9}$. The probability that subsequently the person will travel to Cox's Bazar by bus is $\frac{2}{5}$ and the probability that he will travel by car is $\frac{3}{7}$. Use a probability tree to find the probability that he will travel by train to Chittagong and then by bus to Cox's Bazar.

17. A two-taka coin is tossed four times. (Denote its side with Water Lily flower by L and the side with the primary school going child by C)
- 1) If the coin is tossed twice rather than four times, what is the probability of getting a L and that of not getting a C ?
 - 2) Draw the probability tree of the possible events and write down the sample space.
 - 3) Show that, if the coin was tossed n times, the total number of possible events is 2^n .
18. There are 8 red, 10 white and 7 black marbles in a basket. A marble is chosen randomly.
- 1) Find all possible outcomes.
 - 2) Find the probability of the marble being (1) Red and (2) Not white .
 - 3) If four marbles are picked up one by one without replacing any one of them, then find the probability of all the marbles being white.

Answers to exercises

Exercises 1.1

5. 1) $A = \{1, 3, 5, 7, 9, 11, 13, 15, 17, 19\}$
2) $B = \{2, 3, 5, 7, 11, 13, 17, 19\}$
3) $C = \{3, 5, 7, 11, 13, 17, 19\}$
4) $D = \{1, 2, 3, 5, 7, 9, 11, 13, 15, 17, 19\}$
6. 1) $x = 8$ 2) 56 3) 24
7. 0, 4 8. 0, 3
16. 2) A 17. 3
21. 1) $2 < x < 3$ 2) $x < 1$ or, $x > 5$ 3) $R \setminus \{3 \leq x \leq 5\}$
22. 1) $3 \leq x \leq 4$ 2) $4 < x < 6$
3) $1 < x < 3$ 4) $x \leq 1, x \geq 6, x < 10$
23. 1) $A \cup B = \{-3, -2, -1, 0, 1, 2, 3\}$ 2) $A \cup B = \{6\}$
24. 1) $A \cap B = \{0, 2\}$ 2) $A \cap B = \{b, c\}$
25. 1) 10 2) 50

Exercises 1.2

8. 1) (i) $\text{dom } S = \{1, 2, 3, 4\}$, $\text{range } S = \{5, 10, 15, 20\}$,
 $S^{-1} = \{(5, 1), (10, 2), (15, 3), (20, 4)\}$
(ii) S and S^{-1} each is a function
(iii) one-one function
- 2) (i) $\text{dom } S = \{-3, -2, -1, 0, 1, 2, 3\}$, $\text{range } S = \{-1, 0, 3, 8\}$,
 $S^{-1} = \{(8, -3), (3, -2), (0, -1), (-1, 0), (0, 1), (3, 2), (8, 3)\}$
(ii) S function, S^{-1} not a function, since $(0, 1)$, $(0, -1)$, $(-3, 8)$
 $(3, 8)$, $(-2, 3)$, $(2, 3)$ images are not different
(iii) not one-one function
- 3) (i) $\text{dom } S = \left\{\frac{1}{2}, 1, \frac{5}{2}\right\}$, $\text{range } S = \{-2, -1, 0, 1, 2\}$,
 $S^{-1} = \left\{\left(0, \frac{1}{2}\right), (1, 1), (-1, 1), \left(2, \frac{5}{2}\right), \left(-2, \frac{5}{2}\right)\right\}$
(ii) S not a function since $(1, 1)$ and $(1, -1)$ have different images,
 S^{-1} function
(iii) not one-one function

- 4) (i) $\text{dom } S = \{-3, -1, 0, 1, 3\}$, $\text{range } S = \{-3, -1, 0, 1, 3\}$, $S^{-1} = S$
(ii) S, S^{-1} both are functions
(iii) one-one function
- 5) (i) $\text{dom } S = \{2\}$, $\text{range } S = \{1, 2, 3\}$, $S^{-1} = \{(1, 2), (2, 2), (3, 2)\}$
(ii) S not a function, S^{-1} function
(iii) not one-one function
9. 1) $0, 2, 3$ 2) a 3) 26 4) $1 + y^2$
10. 1) $\text{dom } F = R$, $\text{range } F = R$ 3) $\sqrt[3]{x}$

Exercises 2

7. 1) $(x + 1)^2(x + 2)(x + 3)$
2) $(2a - 1)(a + 1)(a + 2)(2a + 1)$
3) $(x + 1)(x^2 + x + 1)$
4) $(x + y + z)(xy + yz + zx)$
5) $-(x - y)(y - z)(z - x)$
6) $-(a - b)(b - c)(c - a)(a + b)(b + c)(c + a)$
7) $(3x + 4y - 2)(5x - 6y + 3)$
8) $(3x + 4y - 2z)(5x - 6y + 3z)$
10. 1) 1 2) 0 3) $\frac{x}{(x - a)(x - b)(x - c)}$ 4) $\frac{1}{x - 1}$
11. 1) $\frac{2}{x} + \frac{3}{x + 2}$ 2) $\frac{6}{x - 4} - \frac{5}{x - 3}$
3) $\frac{1}{x} - \frac{2}{x - 2} + \frac{2}{x + 3}$ 4) $\frac{1}{5} \left(\frac{7x - 27}{x^2 + 4} - \frac{2}{x + 1} \right)$
5) $\frac{1}{25(2x + 1)} + \frac{12}{25(x + 3)} - \frac{9}{5(x + 3)^2}$

Exercises 5.1

1. $-3, -\frac{3}{2}$
2. $-1 + \frac{\sqrt{10}}{2}, -1 - \frac{\sqrt{10}}{2}$
3. $2 - \sqrt{3}, 2 + \sqrt{3}$
4. $\frac{1}{4}(5 - \sqrt{33}), \frac{1}{4}(5 + \sqrt{33})$
5. $\frac{1}{6}(-7 - \sqrt{37}), \frac{1}{6}(-7 + \sqrt{37})$
6. $\frac{1}{6}(9 - \sqrt{105}), \frac{1}{6}(9 + \sqrt{105})$
7. 4, 4
8. $\frac{1}{4}(-7 - \sqrt{57}), \frac{1}{4}(-7 + \sqrt{57})$
9. $\frac{1}{3}, 2$

Exercises 5.2

- | | | | |
|---------------------------------|-----------------------------------|---------|-------|
| 1. 13 | 2. $\frac{6}{5}$ | 3. 9 | 4. 5 |
| 5. 5 | 6. $\frac{9}{2}, -\frac{9}{2}$ | 7. 1, 5 | 8. 18 |
| 9. $\frac{25}{7}, -\frac{1}{7}$ | 10. $-\frac{3}{2}, -\frac{9}{11}$ | | |

Exercises 5.3

- | | | |
|-----------|---------------------------------|------------------|
| 1. 2 | 2. $\frac{7}{3}$ | 3. $\frac{6}{5}$ |
| 4. 5 | 5. $\frac{2}{2}$ | 6. $\frac{2}{2}$ |
| 7. 3 | 8. 0 | 9. 0, 2 |
| 10. -1, 0 | 11. $-\frac{1}{2}, \frac{1}{2}$ | 12. 2, 3 |

Exercises 5.4

- $(2, 3), \left(\frac{15}{2}, \frac{16}{9}\right)$
- $(3, 4), \left(-, \frac{5}{8}\right)$
- $(0, 0), (13, 13), (3, -2), (-2, 3)$
- $(0, 0), (5, 5), (2, -1), (-1, 2)$
- $\left(\frac{1}{5}, 5\right), \left(\frac{4}{5}, 20\right)$
- $\left(3, -\frac{5}{3}\right), \left(\frac{16}{9}, -\frac{3}{4}\right)$
- $(1, 2), (-1, -2)$
- $(7, 5), (-7, -5), (\sqrt{2}, -6\sqrt{2}), (-\sqrt{2}, 6\sqrt{2})$
- $(3, 4), (4, 3), (-3, -4), (-4, -3)$
- $(2, 1), (2, -1), (-2, 1), (-2, -1)$
- $(1, -2), (2, -1), (-1, 2), (-2, 1)$
- $(1, 3), (-1, -3), \left(\frac{13}{\sqrt{21}}, \frac{2}{\sqrt{21}}\right), \left(-\frac{13}{\sqrt{21}}, -\frac{2}{\sqrt{21}}\right)$

Exercises 5.5

- 16 m., 15 m.
- 13, 9
- length 8 m., width 6 m.
- 19
- (length, width) = (6, 4) m. or $(16, 1\frac{1}{2})$ m.
- length 25 m., width 24 m.
- length 8 m., width 6 m.
- 36
- $8\sqrt{3}$ m.
- length 20 m., width 15 m.

Exercises 5.6

(x, y) respectively:

- $(2, 3)$
- $(2, 1), \left(-\frac{1}{2}, -\frac{1}{4}\right)$
- $(4, 0)$
- $(1, 2)$
- $(3, 3)$
- $(2, \pm 2), \left(-2, \pm \frac{1}{2}\right)$
- $(2, \pm 2), \left(-2, \pm \frac{1}{2}\right)$
- $(1, 2), \left(-\frac{1}{3}, -\frac{2}{3}\right)$
- $(2, \pm 2), \left(-2, \pm \frac{1}{2}\right)$

Exercises 5.7

13. Impossible since both the numbers will be multiple of 5.
 14. $x(x+1) = 10n+6$ where n, x are integers. The last digit of x is either 2, 3 or 7, 8. But such a number can never be a perfect square.
 15. 11 times 16. 22 times 17. 143 times

Exercises 6.1

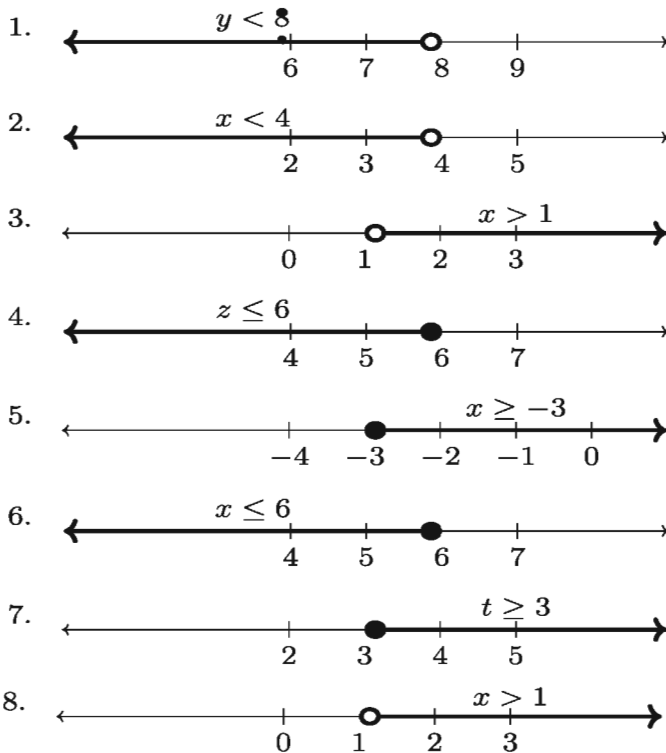

Exercises 6.2

1. $3x + \frac{x+2}{2} < 29, 0 < x < 8$
 2. $4x + (x-3) \leq 40, 3 \leq x \leq \frac{43}{5}$
 3. $70x + 20x < 500, 0 < x \leq 5$
 4. $\frac{x+x+120}{9} \leq 100, 0 < x \leq 390$
 5. $5x < 40, 5 < x < 8$

6. Father's age ≤ 42 years
7. If the current age of Jeny is x , then $14 < x < 17$
8. If time is t seconds then $t \geq 50$
9. If flying time is t hrs. then $t \geq 3\frac{5}{8}$
10. If flying time is t hrs. then $t \geq 2\frac{9}{10}$
11. If the number is x then $0 < x < 5$

Exercises 6.3

12. Prices of rubber, pen and notebook are redpectively Tk. 19, Tk. 26 and Tk. 55
13. 8
14. $72^\circ, 36^\circ$
15. One of length and width will be from $x = 1$ to 7 m., the other one $8 - x$ m.
16. Hint: Such a triangle can be constructed for which $a < c, b < c, a + b < c + 1$ and a and b can be made as big as desired.
17. Sajib will reach earlier

Exercises 7

9. 1) 20, 30, $2r$ 2) $5, \frac{15}{2}, \frac{r}{2}$ 3) $\frac{1}{110}, \frac{1}{240}, \frac{1}{r(r+1)}$ 4) 1, 0, 1 (r even) and 0 (r odd) 5) $\frac{5}{3^9}, \frac{5}{3^{14}}, \frac{5}{3^{r-1}}$ 6) 0, 1, $\frac{1 - (-1)^{3r}}{2}$
10. 1) $n > 10^5$ 2) $n < 10^5$ 3) 0
11. 1) 2 2) $\frac{1}{7}$ 3) $\frac{32}{3}$ 4) sum diverges
- 5) $\frac{1}{3}$
12. 1) $\frac{70}{81}(10^n - 1) - \frac{7n}{9}$ 2) $\frac{50}{81}(10^n - 1) - \frac{5n}{9}$
13. condition $x < -2$ or $x > 0$; sum = $\frac{1}{x}$
14. 1) $\frac{3}{11}$ 2) $2\frac{305}{999}$ 3) $\frac{x}{3330}$ 4) $3\frac{403}{9990}$

Exercises 8.1

1. 1) (i) 1.3177 radians (approx) (ii) 0.9759 radians (approx) (iii) 0.5824 radians (approx)
- 2) (i) $110^\circ 46' 9.23''$ (ii) $75^\circ 29' 54.5''$ (iii) $55^\circ 54' 53.35''$
3. 12.7549 m. (approx) 4. 57 km./hr (approx) 5. $\frac{\pi}{5}$ radians, $\frac{\pi}{2}$ radians
6. $\frac{2\pi}{9}, \frac{\pi}{3}, \frac{4\pi}{9}$ 7. 562 km. (approx) 8. 1,135.3 km. (approx)
9. 4.78 m/s (approx) 10. 1 km. (approx) 11. 1.833 radians (approx)
12. 114.59 m. (approx) 13. 1745 m.(approx) or 1.75 km. (approx)

Exercises 8.2

1. 1) $\frac{1}{\sqrt{6}}$ 2) 2
2. $\tan\theta = \frac{3}{4}, \sin\theta = -\frac{3}{5}$ 3. $\cos A = -\frac{1}{\sqrt{5}}, \tan A = -2$
4. $\sin A = \frac{\sqrt{3}}{2}, \tan A = \sqrt{3}$ 5. $\sin A = -\frac{5}{13}, \cos A = \frac{12}{13}$
9. $\frac{x^2 + y^2}{x^2 - y^2}$
12. 1) $\frac{27}{4}$ 2) $\frac{17}{12}$ 3) $\frac{5}{8}$ 4) $\frac{5\sqrt{3}}{6}$
13. 2

Exercises 8.3

7. 1) 0 2) 0 3) undefined 4) $\frac{1}{\sqrt{3}}$
- 5) $\frac{2}{\sqrt{3}}$ 6) undefined 7) $-\frac{1}{2}$ 8) $\frac{\sqrt{3}}{2}$
9. 1) 0 2) 1 3) 2 4) 2 5) 2
11. 1) $\frac{11\pi}{6}$ 2) $\frac{2\pi}{3}, \frac{4\pi}{3}$ 3) $\frac{4\pi}{3}$ 4) $\frac{7\pi}{4}$
12. 1) $\frac{\pi}{6}$ 2) $\frac{\pi}{3}$ 3) $\frac{\pi}{6}$ 4) $\frac{\pi}{6}, \frac{\pi}{3}$ 5) $\frac{\pi}{3}$
13. 1) $\frac{2\pi}{3}, \frac{4\pi}{3}$ 2) $\frac{\pi}{6}, \frac{5\pi}{6}$ 3) $\frac{\pi}{4}, \frac{3\pi}{4}, \frac{5\pi}{4}, \frac{7\pi}{4}$
- 4) $\frac{\pi}{4}, \frac{3\pi}{4}, \frac{5\pi}{4}, \frac{7\pi}{4}$ 5) $\frac{\pi}{6}, \frac{5\pi}{6}, \frac{7\pi}{6}, \frac{11\pi}{6}$ 6) $\frac{\pi}{3}, \frac{5\pi}{3}$
- 7) $0, \frac{\pi}{3}, \pi, \frac{5\pi}{3}, 2\pi$
16. $\frac{14\sqrt{2}}{\sqrt{3}-1}$

Exercises 9.1

5. 1) $\frac{a^2 - b^2}{ab}$ 2) $\frac{\sqrt{a}}{b}$ 3) x
 4) 1 5) 1 6) $\left(\frac{a}{b}\right)^{a+b}$
8. 1) 0 2) 0 3) $\frac{3}{2}$
9. 1) $x = 0$ 2) $x = 1, y = 1$ 3) $x = -2, y = -2$
 4) $x = -1, y = 1$

Exercises 9.2

9. 1) $x = \ln(1 - y)$ 2) $x = 10^y$
 3) $x = \pm\sqrt{y}$
10. $D_f = (2, \infty), R_f = R$
11. $D_f = (-1, 1), R_f = R$
12. 1) $D_f = [-5, 5], R_f = [0, 5]$ 2) $D_f = [-2, 2], R_f = [0, 4]$
 3) $D_f = R, R_f = \{-1, 0, 1\}$

Exercises 10.1

1. $1 + 5y + 10y^2 + 10y^3 + 5y^4 + y^5$
 1) $1 - 5y + 10y^2 - 10y^3 + 5y^4 - y^5$
 2) $1 + 10x + 40x^2 + 80x^3 + 80x^4 + 32x^5$
2. 1) $1 + 24x + 240x^2 + 1280x^3 + \dots$
 2) $1 - 21x + 189x^2 - 945x^3 + \dots$
3. $1 + 8x^2 + 28x^4 + 56x^6 + \dots$ and 1.082856
4. 1) $1 - 10x + 40x^2 - \dots$
 2) $1 + 27x + 324x^2 + \dots$
5. 1) $1 - 14x^2 + 84x^4 - 280x^6 + \dots$
 2) $1 + \frac{8}{x} + \frac{24}{x^2} + \frac{32}{x^3} + \dots$
 3) $1 - \frac{7}{2} \cdot \frac{1}{x} + \frac{21}{4} \cdot \frac{1}{x^2} - \frac{35}{8} \cdot \frac{1}{x^3} + \dots$
6. 1) $1 - 6x + 15x^2 - 20x^3 + \dots$
 2) $1 + 12x + 60x^2 + 160x^3 + \dots$

Exercises 10.2

8. 1) $32 + 80x^2 + 80x^4 + 40x^6 + 10x^8 + x^{10}$
 2) $64 - \frac{96}{x} + \frac{60}{x^2} - \frac{20}{x^3} + \frac{15}{4x^4} - \frac{3}{8x^5} + \frac{1}{64x^6}$
9. 1) $64 + 576x + 2160x^2 + 4320x^3 + \dots$
 2) $1024 - \frac{640}{x} + \frac{160}{x^2} - \frac{20}{x^3} + \dots$
10. $p = 2, r = 64, s = 60$
11. 7
12. $64 + 48x + 15x^2 + \frac{5}{2}x^3 + \dots, 63.5215$
13. 31.2080
14. $n = 8$, no. of elements 9 and middle element $\frac{35}{128}$
15. 1) $x = \pm 6$ 2) $k = 2$
19. 101^{50} bigger

Exercises 11.1

1. 1) $\sqrt{13}$ units 2) $4\sqrt{2}$ units 3) $|a - b|\sqrt{2}$ units
 4) 1 units 5) $\sqrt{13}$ units
5. $k = -5, 5$
6. 16.971 (approx)
9. B near, A far
11. $\frac{3}{2}\sqrt{13}$

Exercises 11.2

1. 1) 7 units, $4\sqrt{2}$ units, 5 units, $12 + 4\sqrt{2}$ units
 2) 14 sq. units
2. 1) 6 sq. units 2) 24 sq. units
3. $\sqrt{58}$ units, $\sqrt{10}$ units, 11.972 sq. units

4. $2a^2$ sq. units
5. 10 units, 10 units, 40 sq. units
6. If $a = 5$ then $\frac{119}{2}$ sq. units, If $a = 15$ then $\frac{169}{2}$ sq. units
7. $a = 2, 5\frac{1}{3}$
 If $a = 2$ then, ABC right-angled triangle, AC hypotenuse and $\angle BAC$ right angle
8. 1) 21 sq. units 2) 24 sq. units 3) 15 sq. units
10. $p = \frac{59}{5}$

Exercises 11.3

1. 1) -1 2) $\frac{3}{2}$ 3) 0 4) 2
2. 5 4. $1, \frac{1}{2}$ 5. $1, 2$

Exercises 11.4

10. $y = 2x - 5$
11. 1) $y = -x + 6$ 2) $y = x - 3$ 3) $y = 3x - 3a$
12. 1) $y = 3x + 5$ 2) $y = 3x - 5$ 3) $y = -3x + 5$
 4) $y = -3x - 5$
13. 1) $(1, 0), (0, -3)$ 2) $(-\frac{6}{5}, 0), (0, 3)$ 3) $(\frac{4}{3}, 0), (0, -2)$
14. $y = k(x - k), k = 2, 3$
15. $y = \frac{1}{k}(x + k^2), k = -1, 2$
16. $k = \frac{11}{2}$
17. 1) $y = 3x + 9$ and $y = -2x + 4$ 2) 15 sq. units

Exercises 13

- | | |
|-------------------------------------|------------------------------|
| 7. 636 sq.m., 20.5 m., 864 cubic m. | 8. 1 cubic m. , 7.8 sq.m. |
| 9. 300 sq.cm. | 10. 8.75 m., 3.2 m. |
| 11. 301.6 sq.cm., 301.6 cc | 12. 25 cm. |
| 13. 64.14 cc | 14. 452.39 sq.cm., 904.8 cc |
| 15. 1 cm. | 16. 11.37 cm. |
| 17. 1.06 cm. | 18. 4 units |
| 19. 1308.82 cc | 20. 78.54 sq.cm. |
| 21. 7.48 sq.m., Tk. 107.98 | 22. 83800 units |
| 23. 16 cm., 12 cm., 12 cm. | 24. 2086.49 sq.m. |
| 25. 798 sq.cm., 1550 cc | 26. 203.14 sq.cm., 207.85 cc |
| 27. 296.38 sq.cm. 311.77 cc | 28. 110.85 sq.cm., 60.34 cc |
| 29. 40.65 sq.cm., 16 cc | 30. 4662.86 cc |

Exercises 14

- | | | | |
|---------------------------|------------------------|-----------------------|-------------------|
| 7. 1) $\frac{1}{2}$ | 2) $\frac{7}{30}$ | 3) $\frac{3}{30}$ | 4) $\frac{4}{15}$ |
| 8. $\frac{1}{38}$ | | | |
| 9. $\frac{2}{3}$ | | | |
| 10. $\frac{98}{639}$ | | | |
| 11. 1) $\frac{157}{1897}$ | 2) $\frac{1630}{1897}$ | 3) $\frac{424}{1897}$ | |
| 12. 1) $\frac{23}{1000}$ | 2) $\frac{1}{400}$ | | |
| 15. 1) $\frac{8}{63}$ | 2) $\frac{25}{63}$ | | |
| 16. $\frac{4}{45}$ | | | |

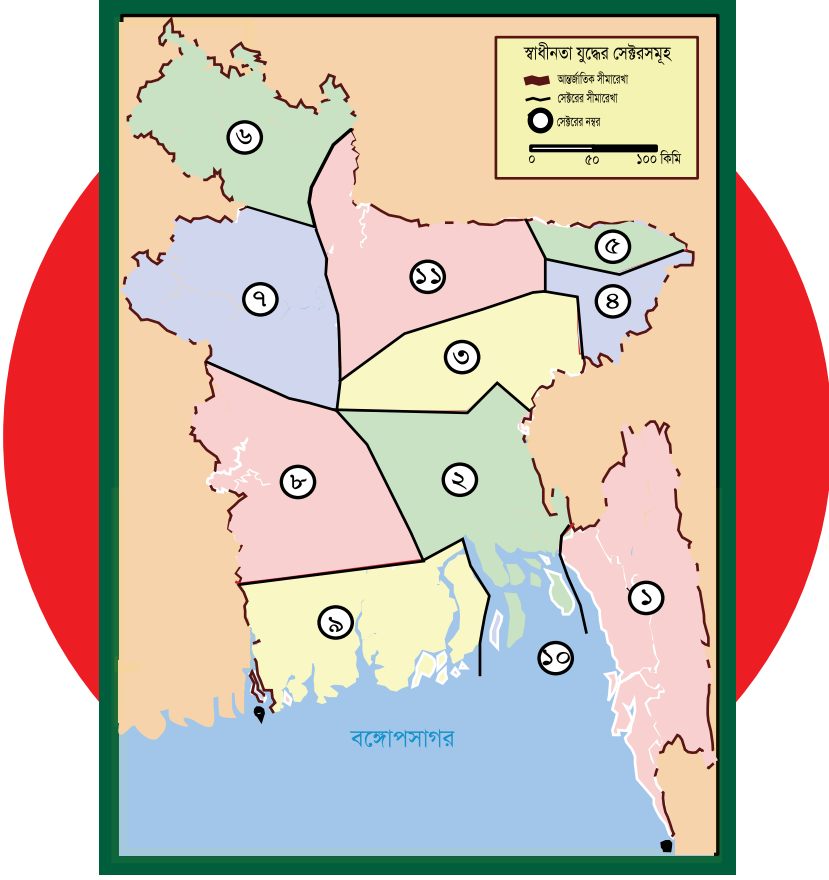

মুক্তিযুদ্ধের ১১টি সেক্টর

১ নং সেক্টর- চট্টগ্রাম, পার্বত্য চট্টগ্রাম এবং নোয়াখালী জেলার পূর্বাঞ্চল, ২ নং সেক্টর- নোয়াখালীর অংশবিশেষ, কুমিল্লার অংশবিশেষ, আখাউড়া, ভৈরব এবং ঢাকা ও ফরিদপুর জেলার অংশবিশেষ, ৩ নং সেক্টর- কুমিল্লার অংশবিশেষ, হবিগঞ্জ, কিশোরগঞ্জ ও ঢাকার অংশবিশেষ, ৪ নং সেক্টর- সিলেটের পূর্বাঞ্চল, ৫ নং সেক্টর- সিলেটের পশ্চিমাঞ্চল, ৬ নং সেক্টর- রংপুর ও ঠাকুরগাঁও, ৭ নং সেক্টর- রাজশাহী ও দিনাজপুরের অংশবিশেষ, ৮ নং সেক্টর- কুষ্টিয়া, যশোর, ফরিদপুর ও খুলনার অংশবিশেষ, ৯ নং সেক্টর- সাতক্ষীরা ও খুলনার অংশবিশেষ, বরিশাল ও পটুয়াখালী জেলা, ১০ নং সেক্টর- নৌ সেক্টর অর্থাৎ সমুদ্র উপকূলীয় অঞ্চল ও অভ্যন্তরীণ নৌ পথ, ১১ নং সেক্টর- ময়মনসিংহ ও টাঙ্গাইল।

বঙ্গবন্ধুর স্বাধীনতার ঘোষণার মধ্য দিয়ে ১৯৭১ সালের ২৬শে মার্চ বাংলাদেশের স্বাধীনতা যুদ্ধ শুরু হয়। যুদ্ধের রণকৌশল হিসেবে সমগ্র বাংলাদেশকে ১১টি সেক্টর ও ৬৪টি সাব সেক্টরে ভাগ করা হয়। প্রতিটি সেক্টরের নেতৃত্বে ছিলেন একজন সেক্টর কমান্ডার। কমান্ডারদের সফল নেতৃত্বে মুক্তিযোদ্ধাদের সর্বাঙ্গিক অংশগ্রহণের মধ্য দিয়ে ধীরে ধীরে মুক্ত হয় দেশের বিভিন্ন অঞ্চল। এভাবে ১৯৭১ সালের ১৬ই ডিসেম্বর বিজয় অর্জিত হয়। বিভিন্ন সেক্টরের উল্লেখযোগ্য কয়েকটি যুদ্ধের মধ্যে রয়েছে- কামালপুর যুদ্ধ, বিলোনিয়ার যুদ্ধ, ভাটিয়াপাড়ার যুদ্ধ, রাধানগর যুদ্ধ।

2023

Academic Year
9-10 Higher Math

‘সকল বিজ্ঞানের রানি হচ্ছে গণিত।’ – কার্ল ফ্রেডারিক গাউস

সমৃদ্ধ বাংলাদেশ গড়ে তোলার জন্য যোগ্যতা অর্জন কর
– মাননীয় প্রধানমন্ত্রী শেখ হাসিনা

তথ্য, সেবা ও সামাজিক সমস্যা প্রতিকারের জন্য ‘৩৩৩’ কলসেন্টারে ফোন করুন

নারী ও শিশু নির্যাতনের ঘটনা ঘটলে প্রতিকার ও প্রতিরোধের জন্য ন্যাশনাল হেল্পলাইন সেন্টারে
১০৯ নম্বর-এ (টোল ফ্রি, ২৪ ঘণ্টা সার্ভিস) ফোন করুন



Ministry of Education

For free distribution from academic year 2010 by the Government of the
People's Republic of Bangladesh